

THIS DRAWING IS UNPUBLISHED. RELEASED FOR PUBLICATION 20
 © COPYRIGHT 20 BY - ALL RIGHTS RESERVED.

REVISIONS

P	LTR	DESCRIPTION	DATE	DWN	APVD
	A	RELEASED AS PER ECR-15-013198	16SEP2015	MKD	RRP

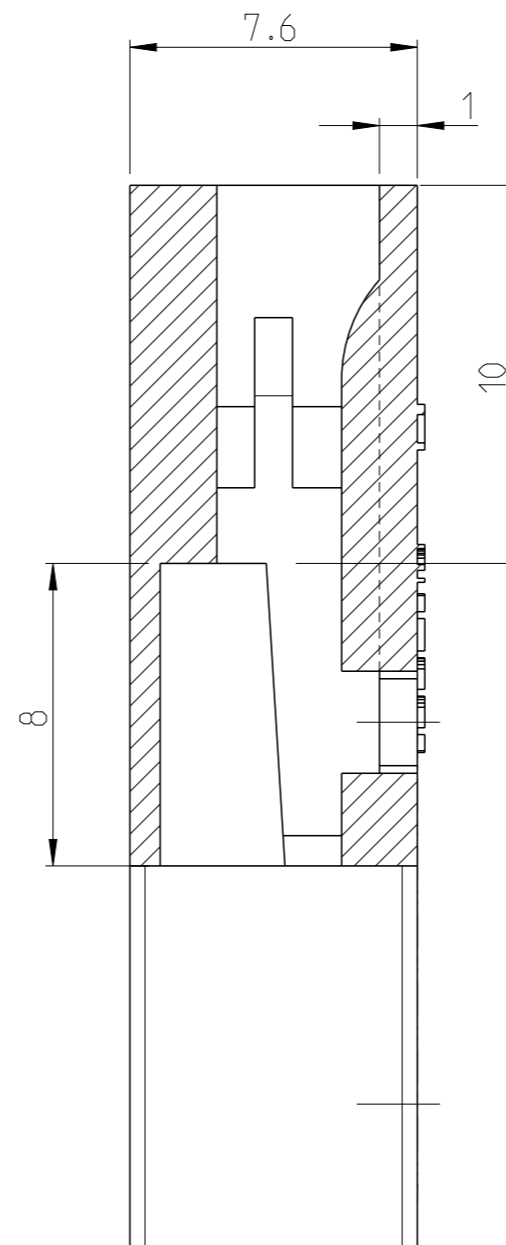
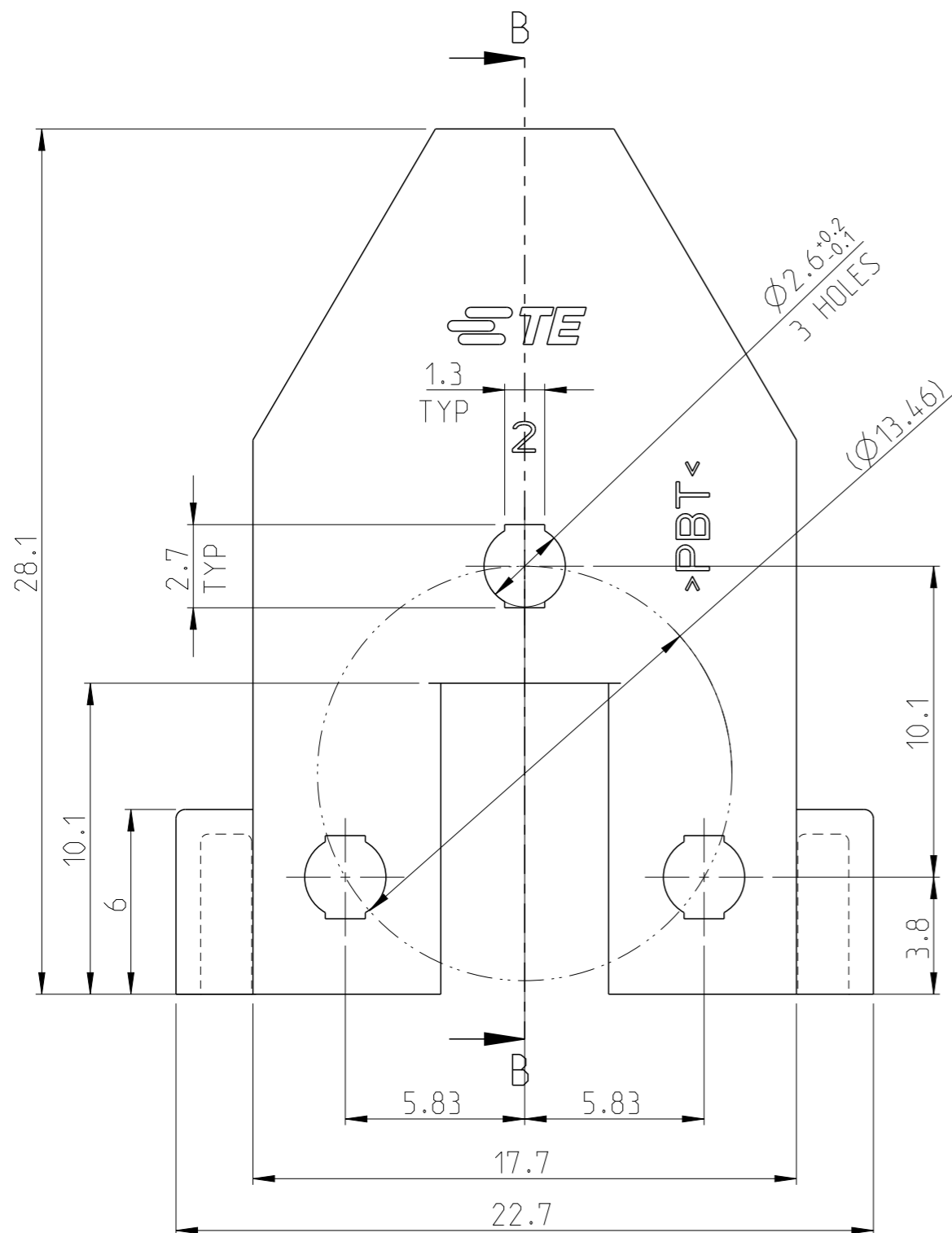

NOTE:

1. ALL THREE CAVITIES ARE IDENTICAL
2. 3 TYPICAL CAVITIES SUITABLE FOR CONTACT 2825083-1

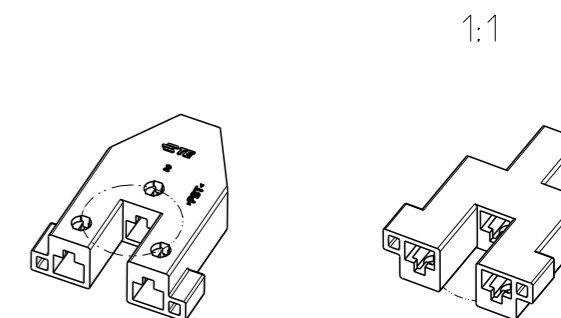

SECTION B-B

BLACK	PBT GF (UL94 V0 & GWT 750)	2825082-2	A
NATURAL	PBT GF	2825082-1	A
FINISH	MATERIAL	PART NO	REV

THIS DRAWING IS A CONTROLLED DOCUMENT.

DIMENSIONS: mm	TOLERANCES UNLESS OTHERWISE SPECIFIED:
	0 PLC ±0.3
	1 PLC ±0.3
	2 PLC ±0.2
	3 PLC ±
	4 PLC ±
	ANGLES ±°
MATERIAL SEE TABLE	FINISH

DWN	14OCT2014
CHK	DHANESH
CHK	DHANESH
APVD	14OCT2014
APVD	RAJENDRA
PRODUCT SPEC	108-5205
APPLICATION SPEC	-
WEIGHT	-

TE Connectivity		NAME	
		CLUSTER BLOCK HOUSING .090	
SIZE	CAGE CODE	DRAWING NO	RESTRICTED TO
A3	-	©-2825082	-
Customer Drawing		SCALE	SHEET
		5:1	1 OF 1
			REV
			A