

NON-ROHS COMPLIANT VERSION

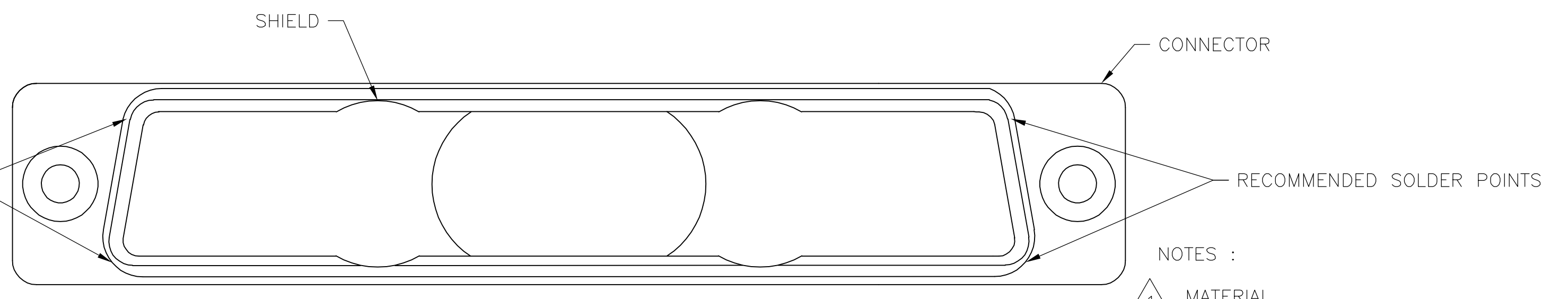

- NOTES :
- MATERIAL
 INSERT: PBT, BLACK, UL94V-0 RATED
 CONTACT & JACKSCREWS: BRASS
 SHELLS & SHIELD: STEEL
 ENCLOSURE: PVC, BLACK
 - FINISH
 CONTACT: GOLD PLATING 0.02µm[.0000008] MIN ON CONTACT AREA 2.3µm[.000090] MIN TIN-LEAD PLATING ON SOLDER AREA. ALL OVER 1.27µm[.000050] MIN NICKEL.
 SHELL: 2.4µm[.000095] MIN TIN
 SHIELD: 2.0-3.0µm[.000080-.000120] TIN
 - SPECIFICATION
 ELECTRICAL CHARACTERISTICS:
 CURRENT RATING: 3 AMPERES
 DIELECTRIC WITHSTANDING VOLTAGE: AC 1000V r.m.s
 INSULATION RESISTANCE: 5000 MEGOHMS MINIMUM AT DC 500V
 CONTACT RESISTANCE: 10 MILLIOHMS MAXIMUM.
 - RECEPTACLE CONNECTOR FULLY LOADED WITH CONTACTS. ALL OTHER PARTS ARE SHIPPED UNASSEMBLED, EACH PART INDIVIDUALLY BULK PACKED.
 - SOLDER CUP WILL ACCOMMODATE 20 MAX AWG WIRE.
 - FINISH
 CONTACT: GOLD PLATING 0.02µm[.0000008] MIN ON CONTACT AREA 2.3µm[.000090] MIN TIN PLATING ON SOLDER AREA. ALL OVER 1.27µm[.000050] MIN NICKEL.
 SHELL: 2.4µm[.000095] MIN TIN
 SHIELD: 2.0-3.0µm[.000080-.000120] TIN
 - ROHS 2002/95/EC COMPLIANT PART(SEE SHEET 2)

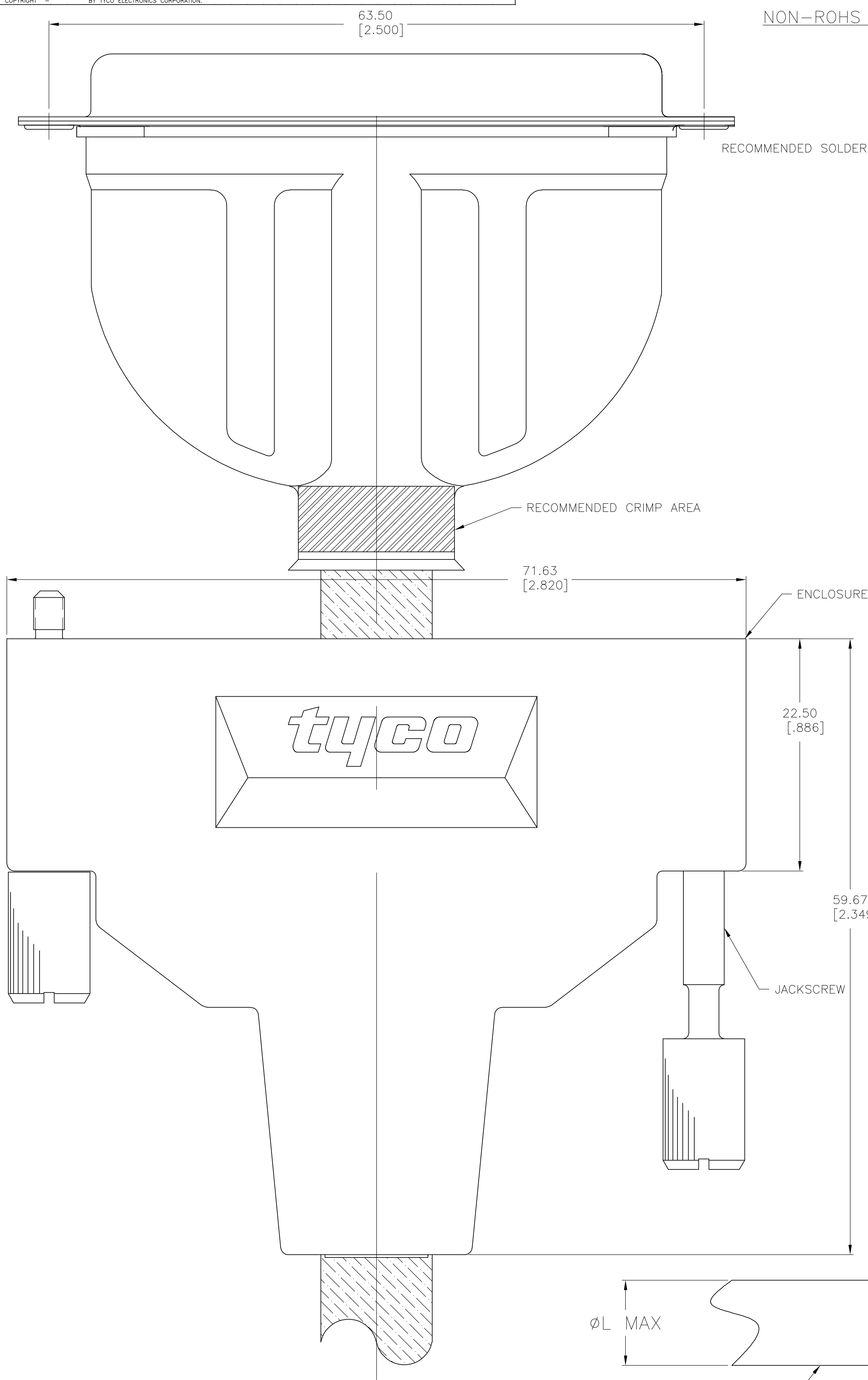
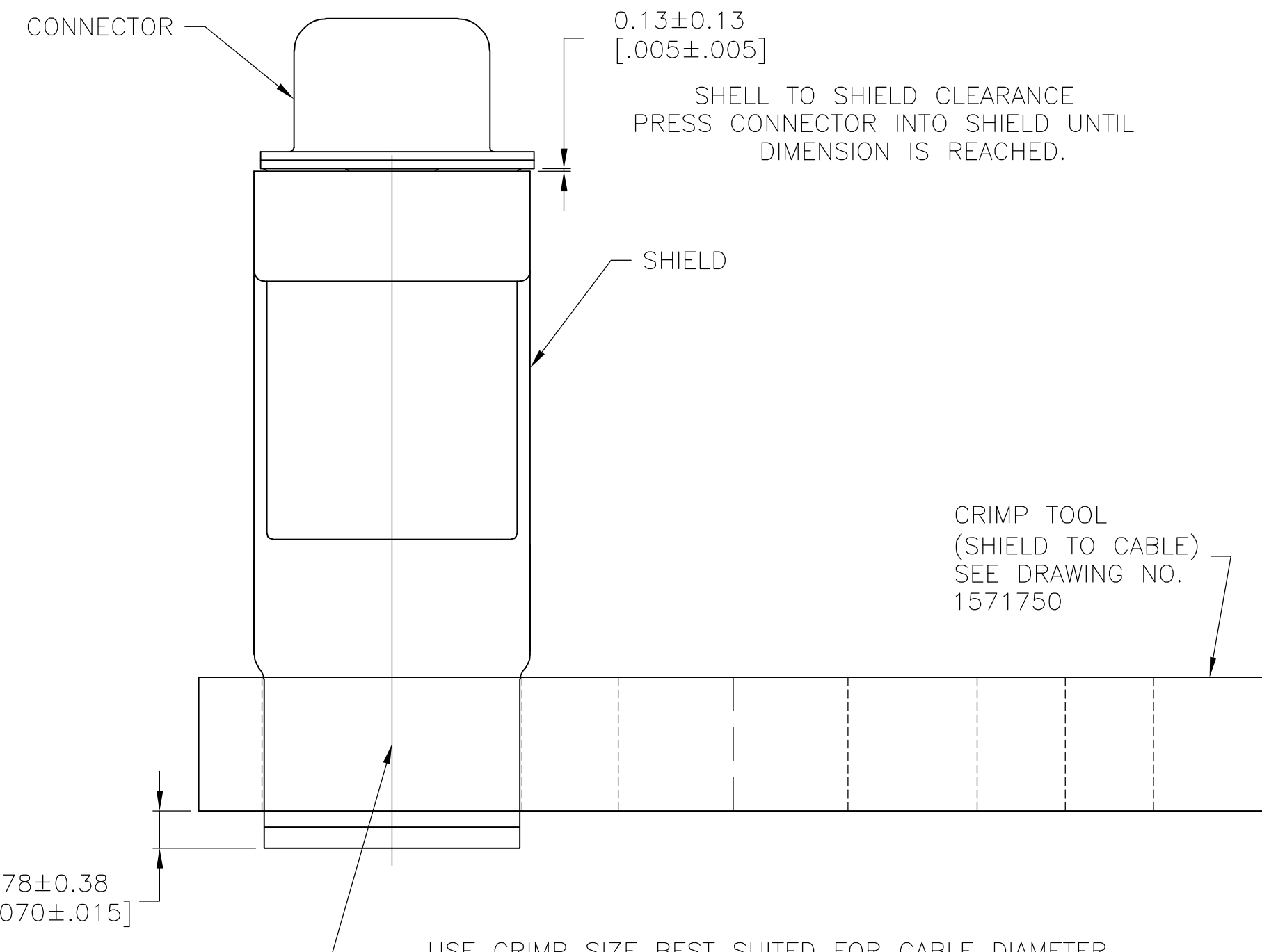

ASSEMBLY INSTRUCTIONS

- USE SHIELD ENCLOSURE EXPANSION TOOL, 58241-1 TO GET ENCLOSURE ON CABLE.
- PREPARE CABLE AS SHOWN.
- PLACE CABLE THROUGH SHIELD.
- SOLDER CONDUCTORS TO CONTACTS.
- PRESS SHIELD ONTO CONNECTOR AS SHOWN.
- SOLDER SHIELD TO CONNECTOR AS SHOWN (OPTIONAL).
- METALLIC SHIELD SURFACES AND INTERIOR ENCLOSURE SURFACE MUST BE CLEAN AND DRY PER 3M REQUIREMENTS.
- CUT TWO PIECES OF 3M/SCOTCH VHB 4926, DOUBLE COATED ADHESIVE TAPE 6 TO 8mm WIDE BY 45 TO 52mm LONG.
- APPLY TAPE TO METALLIC SHIELD SURFACE. LENGTHWISE. ADJACENT TO CONNECTOR FLANGE.
- REMOVE ADHESIVE BACKING FROM TAPE AND PUSH ENCLOSURE OVER METALLIC SHIELD.
- BOND STRENGTH IS DEPENDANT ON THE AMOUNT OF SURFACE CONTACT DEVELOPED. A FIRM APPLICATION DEVELOPS A BETTER BOND. ULTIMATE SURFACE CONTACT CAN BE ACCOMPLISHED BY CLAMPING ENCLOSURE TO THE SHIELD. CARE SHOULD BE TAKEN NOT TO MAR THE POLYMER SURFACE. SHIMS MAY BE REQUIRED TO EVENLY DISTRIBUTE THE CLAMPING FORCE ACROSS THE POLYMER.
- ULTIMATE BOND STRENGTH IS DEVELOPED AFTER 72 HOURS, BUT MAY BE ACCELERATED BY EXPOSURE TO 66°C FOR 1 HOUR, IF THE CLAMPS ARE COMPATIBLE WITH THIS TEMPERATURE.
- INSERT JACK SCREWS.

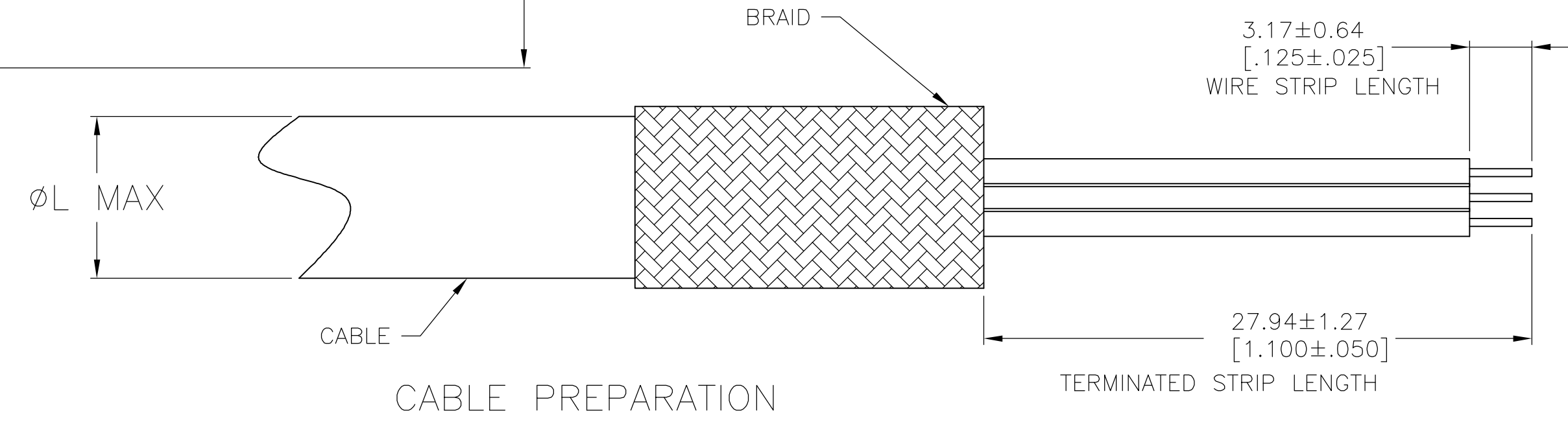

8	6	10.8 [.425]	1571657-2
SUPERSEDED BY 1571657-2		2	10.8 [.425]
		FINISH	CABLE DIA L
			PART NUMBER

THIS DRAWING IS A CONTROLLED DOCUMENT.

DIMENSIONS: mm [NCHES]	TOLERANCES UNLESS OTHERWISE SPECIFIED:	0 PLC ± .012	1 PLC ± .012	2 PLC ± .012	3 PLC ± .012	4 PLC ± .012	ANGLES ± .012
------------------------	--	--------------	--------------	--------------	--------------	--------------	---------------

DIN M. BINNER	21NOV03	tyco	Tyco Electronics Corporation
CHK		NAME	Harrisburg, Pa 17105-3608
APVD		PRODUCT SPEC	BULK KIT, RECEPTACLE, AMPLIMITE
		108-40031	SOLDER CUP SHIELDING ENCLOSURE
		APPLICATION SPEC	37 POSITION, SIZE 4
MATERIAL	FINISH	SIZE	CAGE CODE
		A1	00779
		WEIGHT	DRAWING NO
			1571657
		CUSTOMER DRAWING	SCALE
			4:1
		SHEET	1 OF 2
		REV	D2

ROHS 2002/95/EC COMPLIANT VERSION

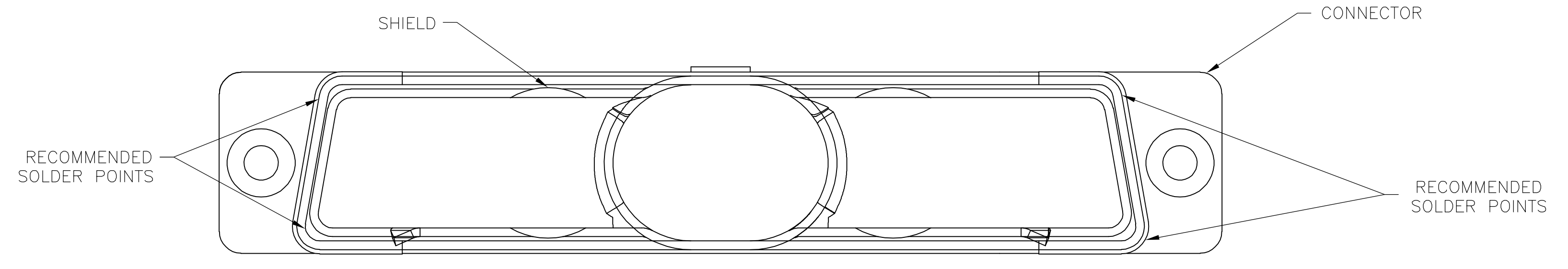
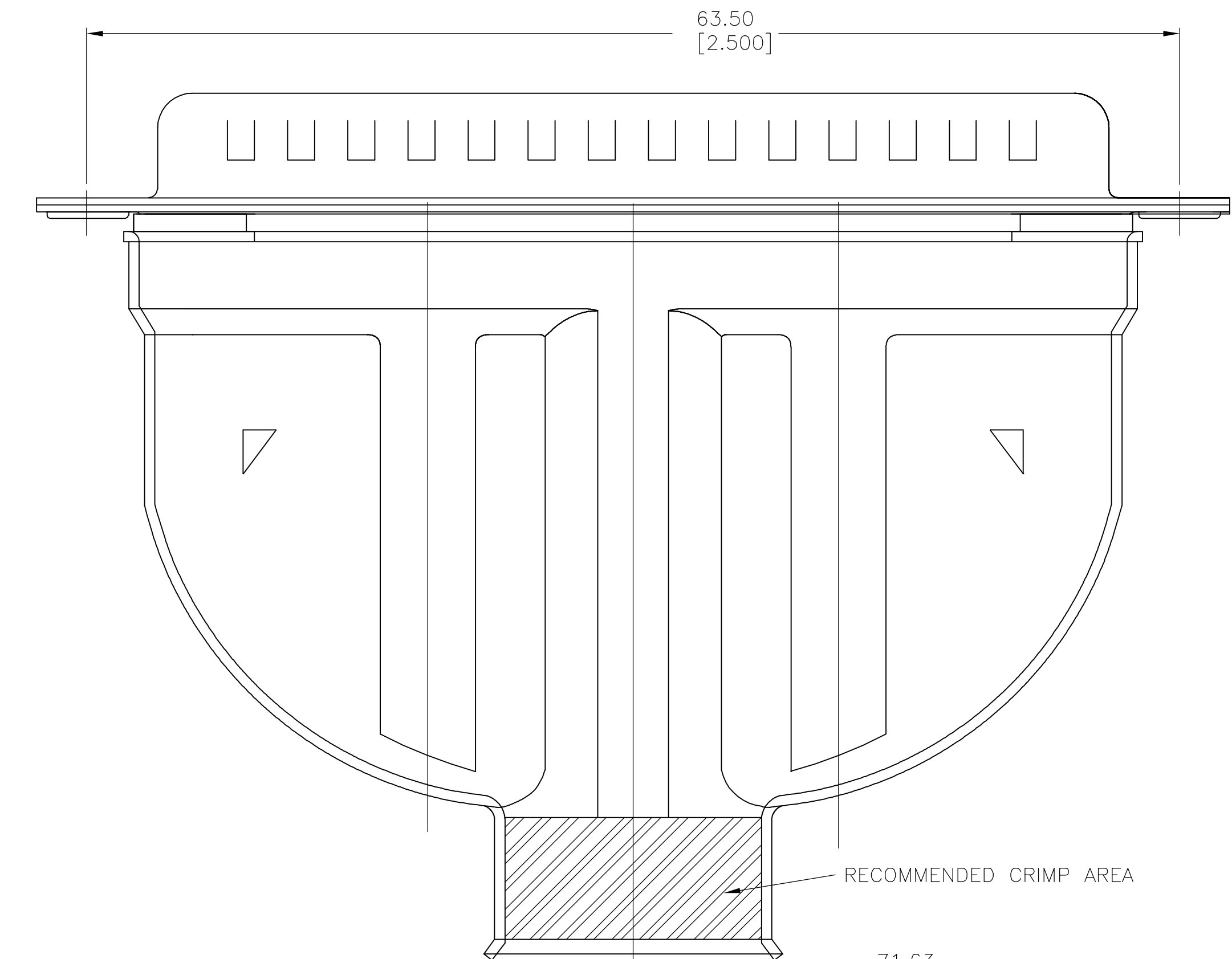

SOLDER LOCATION (OPTIONAL)

ASSEMBLY INSTRUCTIONS

- USE SHIELD ENCLOSURE EXPANSION TOOL, 58241-1 TO GET ENCLOSURE ON CABLE.
- PREPARE CABLE AS SHOWN.
- PLACE CABLE THROUGH SHIELD.
- SOLDER CONDUCTORS TO CONTACTS.
- PRESS SHIELD ONTO CONNECTOR AS SHOWN.
- SOLDER SHIELD TO CONNECTOR AS SHOWN (OPTIONAL).
- CRIMP SHIELD TO CABLE AS SHOWN IN CRIMP DETAIL.
- PRESS ENCLOSURE OVER SHIELD UNTIL CONNECTOR FLANGE IS FLUSH WITH ENCLOSURE EDGE.
- INSERT JACKSCREWS.

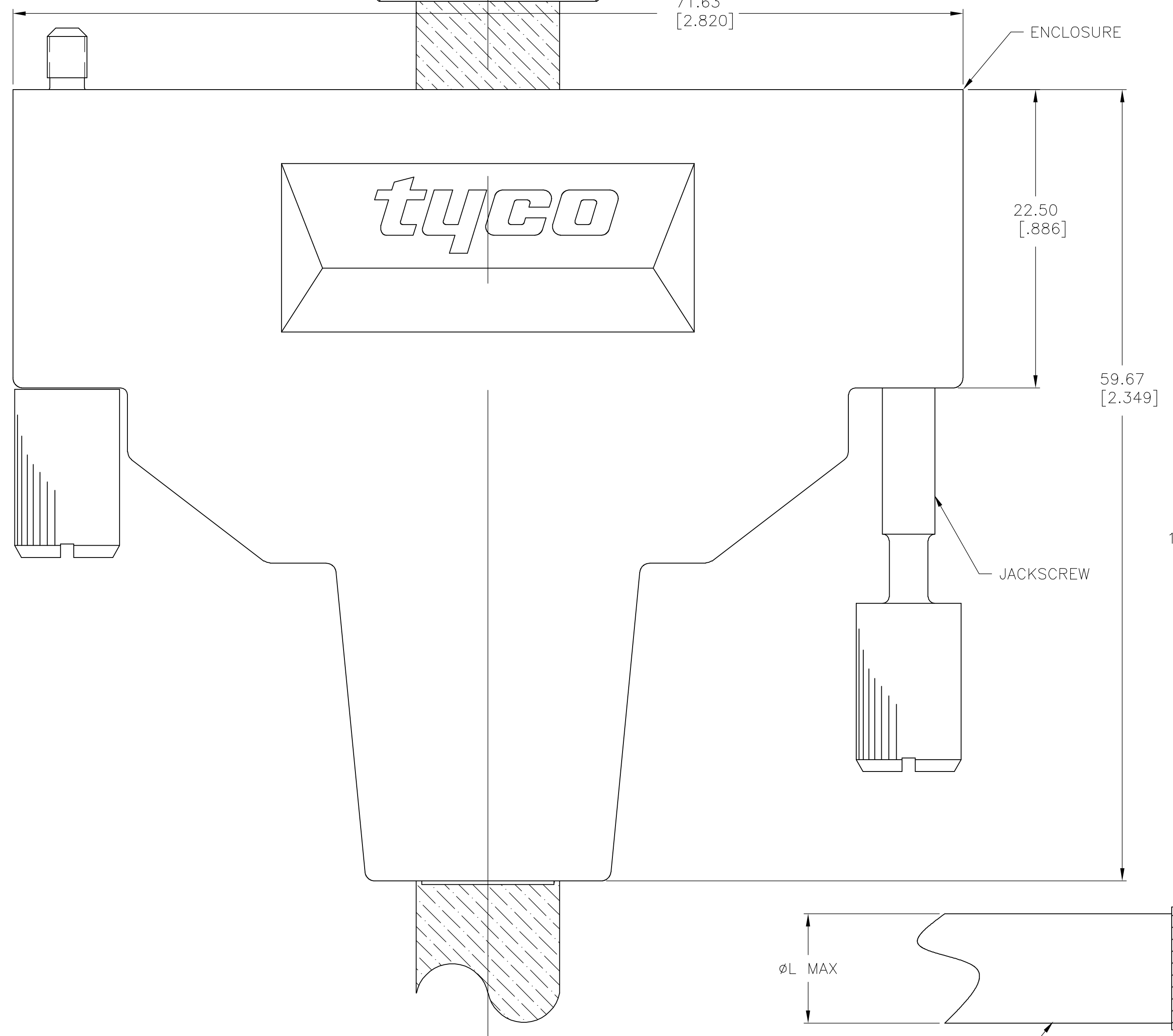

EXPLODED VIEW OF ASSEMBLED KIT

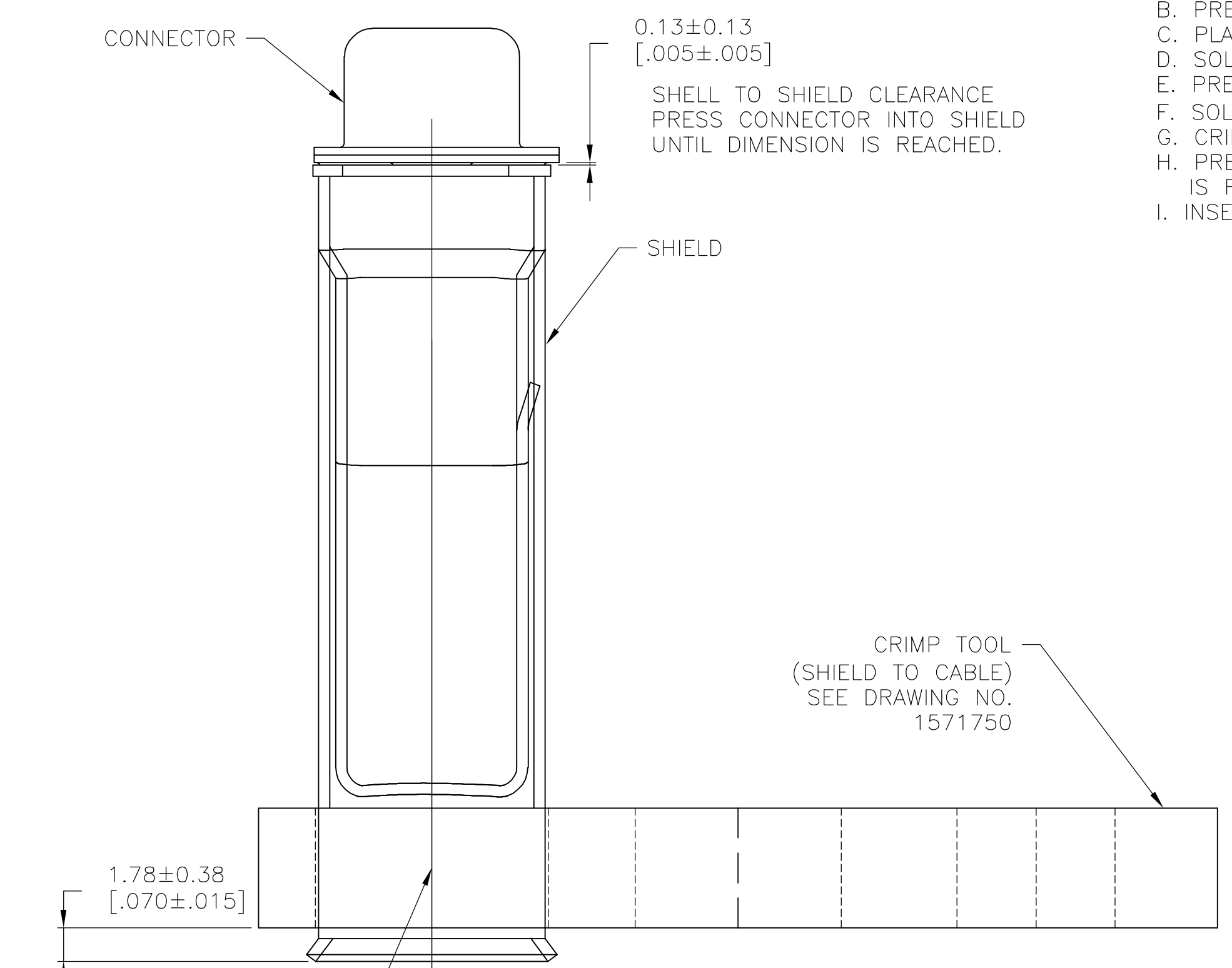

USE CRIMP SIZE BEST SUITED FOR CABLE DIAMETER SHIELD TO CABLE CRIMP

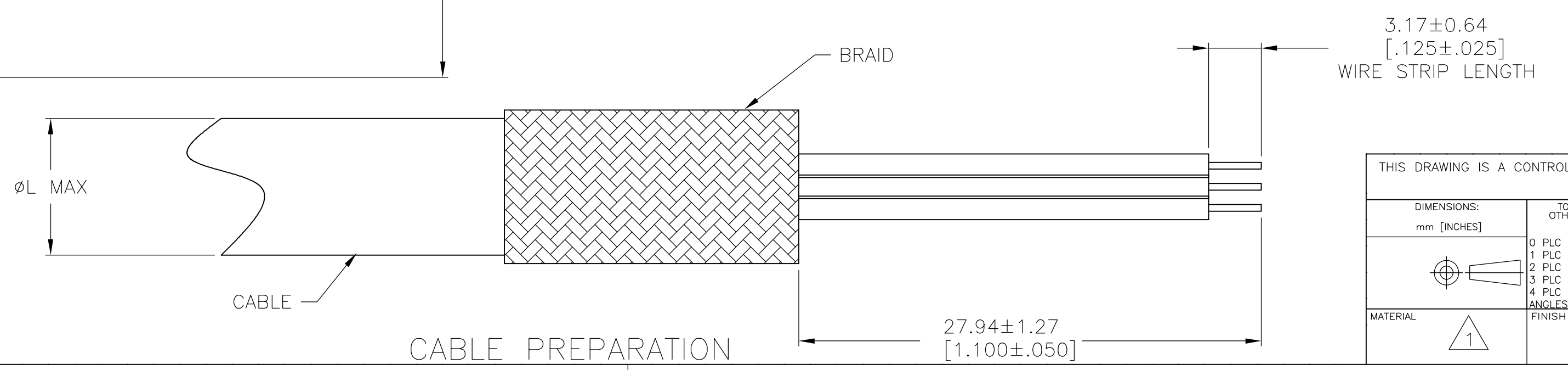

CABLE PREPARATION

THIS DRAWING IS A CONTROLLED DOCUMENT.		DWN	M. BINNER	21NOV03	tyco Electronics	Tyco Electronics Corporation Harrisburg, Pa 17105-3608
DIMENSIONS: mm [INCHES]		CHK				NAME
TOLERANCES UNLESS OTHERWISE SPECIFIED:		APVD			PRODUCT SPEC	108-40031
0 PLC ± -					APPLICATION SPEC	
1 PLC ± 0.3[.012]					SIZE	A1
2 PLC ± -					CAGE CODE	00779
3 PLC ± -					DRAWING NO	1571657
4 PLC ± -					RESTRICTED TO	
ANGLES ± -					WEIGHT	
FINISH					CUSTOMER DRAWING	