

PART NUMBER	REV	FIRST USED
680519-1	A	122500-1
680519-2	A	565435-5
680519-3	A	354500-1

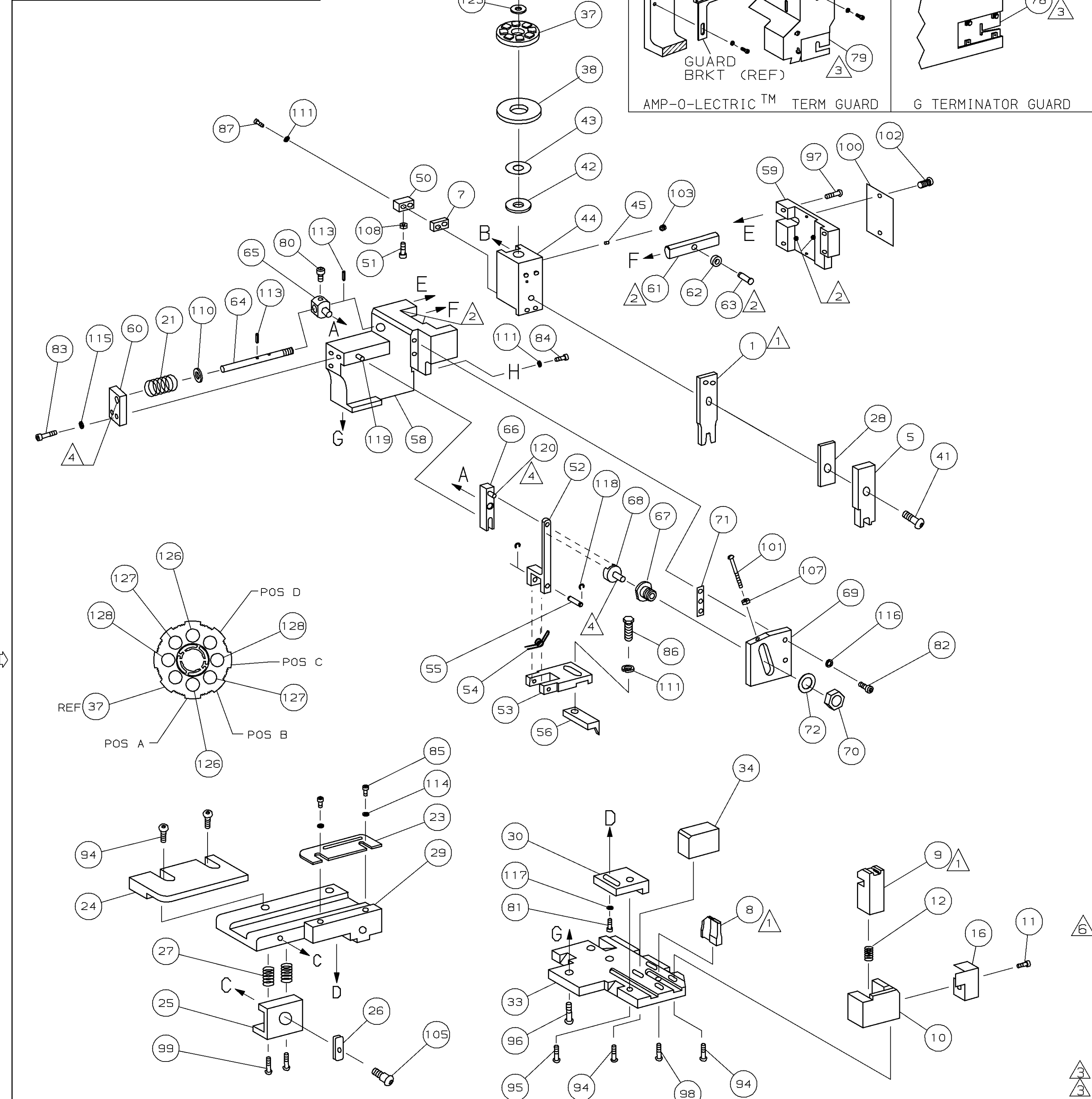

TERMINAL NAME: TERMINAL, SWITCH		CRIMPING DATA	
PAD LTR	CRIMP HEIGHT	WIRE SIZE	
A	.074 ±.002 [1.88 ±0.05mm]	16	
B	.068 ±.002 [1.73 ±0.05mm]	18	
C	.064 ±.002 [1.63 ±0.05mm]	20	
D	NOT	USED	
CRIMP	SIZE	TYPE	RANGE
WIRE	.110 [2.79mm]	F	20-16
INSUL	-	-	-

QTY REQD PER ASSY	TERM APPL	SPEC	FEED	APPL INSTRUCTION	SET UP GAGE	LAYOUT
.236	NONE		.500	408-8040	458637-1	L1979

QTY REQD PER ASSY	TERM APPL	SPEC	FEED	APPL INSTRUCTION	SET UP GAGE	LAYOUT	
2	2	2	-	C	8-354778-7	PIN, WIRE DISC (.2930)C	129
2	2	2	-	C	8-354778-1	PIN, WIRE DISC (.2900)B	127
2	2	2	-	C	6-354778-9	PIN, WIRE DISC (.2840)A	126
1	1	1	-	A	986950-1	WASHER, FLAT PRECISION	125
1	1	1	-	A	217238-1	GENERAL INSTRUCTION PACKAGE	124
1	1	1	-	-	4088040	SF APPL INST 408-8040	123
							122
							121
REF	REF	REF	-	A	1-21030-1	PIN, DOWEL (Ø.187x.50) LEVER	120
REF	REF	REF	-	A	1-21030-6	PIN, DOWEL (Ø.187x1.25) HOUSING	119
REF	REF	REF	-	A	21045-3	RING, RET "C" (Ø.187) FD FING PIN	118
1	1	1	-	A	21024-5	WASHER, LOCK (#10) ADJ BLOCK	117
REF	REF	REF	-	A	21024-5	WASHER, LOCK (#10) ADJ PLATE	116
REF	REF	REF	-	A	21024-5	WASHER, LOCK (#10) FEED GDE ROD	115
2	2	2	-	A	21024-2	WASHER, LOCK (#4) FRONT STP GUIDE	114
REF	REF	REF	-	A	5-21028-1	PIN, SLT SPR (Ø.125x.50) ADJ ROD	113
							112
4	4	4	-	A	21024-4	WASHER, LOCK (#8) STRIPPER	111
REF	REF	REF	-	A	21899-4	WASHER, FLAT (Ø5/16) SCREW ADJ	110
							109
1	1	1	-	A	21018-5	NUT, HEX (NO. 6) HOLDDOWN	108
REF	REF	REF	-	A	21018-5	NUT, HEX (6-32) FEED ADJ	107
							106
1	1	1	-	A	22353-8	SCR, SHLD (Ø.187x.25) DRAG LEVER	105
1	1	-	-	A	992031-1	PIN, CLEVIS	104
1	1	1	-	A	21009-2	SCR, SKT SET (1/4-20x.25 LW) RAM	103
2	2	2	-	A	21017-2	SCR, DRIVE (#2x.19) ID PLATE	102
REF	REF	REF	-	A	6-23715-5	SCR, PAN HD (6-32x1.50) FEED ADJ	101
1	1	1	-	B	461264-1	PLATE, IDENTIFICATION	100
2	2	2	-	A	3-21002-0	SCR, BHC (10-32x.88) DRAG	99
1	1	1	-	A	22733-8	SCR, BHC (8-32x.38 LW) ANVIL	98
REF	REF	REF	-	A	2-21002-9	SCR, BHC (10-32x.75) CAP	97
REF	REF	REF	-	A	2-22733-8	SCR, BHC (1/4-20x.62) HOUSING	96
REF	REF	REF	-	A	2-21002-7	SCR, BHC (10-32x.50) SG ADJ BLOCK	95
6	6	6	-	A	2-21002-2	SCR, BHC (8-32x.50) TERM H DWN	94
							93
							92
							91
1	1	1	-	A	1-21002-7	SCR, BHC (6-32x.38) CAM	90
							89
1	1	-	-	A	7-21000-9	SCR, SHC (4-40x.19) STRIPPER	88
							87
2	2	2	-	A	2-21000-9	SCR, SHC (8-32x.70) DEP-HOLD	86
1	1	1	-	A	2-22603-0	SCR, HEX HD (8-32x.31) FEED FINGER	85
2	2	2	-	A	1-21000-3	SCR, SHC (4-40x.25) F ST GUIDE	84
1	1	1	-	A	2-21000-7	SCR, SHC (8-32x.50) STRIPPER	83
REF	REF	REF	-	A	3-21000-7	SCR, SHC (10-32x.75) FEED ROD GD	82
REF	REF	REF	-	A	3-21000-6	SCR, SHC (10-32x.62) FD ADJ BLK	81
1	1	1	-	A	3-21000-4	SCR, SHC (10-32x.38) SG ADJ BL	80
REF	REF	REF	-	A	3-21000-4	SCR, SHC (10-32x.38) PIVOT BLK	79
-	REF	-	-	B	455749-1	GUARD, WINDOW	78
REF	-	-	-	B	679532-1	INSERT, GUARD	77
							76
							75
							74
							73
REF	REF	REF	-	A	458109-1	WASHER, SPECIAL	72
REF	REF	REF	-	A	690517-1	SPACER	71

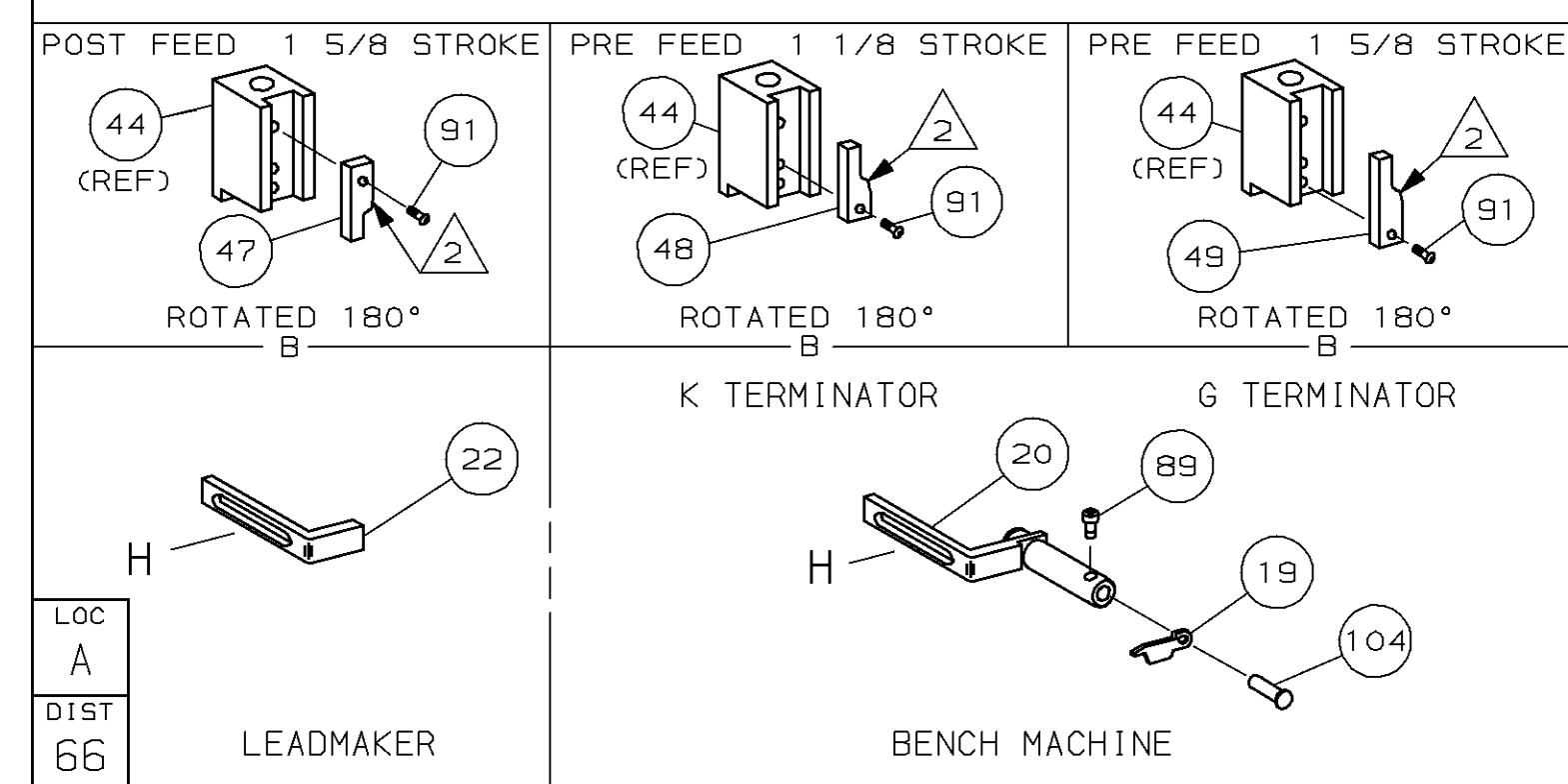

- 1 RECOMMENDED SPARE PARTS.
- 2 GREASE LIGHTLY.
- 3 GUARD MUST BE IN PLACE WHEN OPERATING APPLICATOR IN A BENCH MACHINE.
- 4 LUBRICATE DAILY USING NO. 20 MACHINE OIL.
- 5. ITEMS WITH QTY OF REF SPECIFIED (EXCEPT ITEMS 78 AND 79) ARE USED ON ITEM 46.
- 6 CUT TO LENGTH AT ASSY.

QTY REQD PER ASSY	TERM APPL	SPEC	FEED	APPL INSTRUCTION	SET UP GAGE	LAYOUT	
1	1	1	-	B	690542-2	PAWL, FEED	56
REF	REF	REF	-	B	240624-1	PIN, FEED FINGER	55
REF	REF	REF	-	B	691499-1	SPRING, FEED FINGER	54
REF	REF	REF	-	B	690541-1	HOLDER, FEED FINGER	53
REF	REF	REF	-	A	455679-1	LEVER, TERMINAL FEED ARM	52
1	1	1	-	A	811242-2	BUMPER, HOLDDOWN	51
1	1	1	-	A	690753-1	SPACER, TONKER	50
1	-	-	-	B	690602-6	CAM, PRE-FEED 1 5/8 ST	49
-	1	-	-	B	690602-5	CAM, PRE-FEED 1 1/8 ST	48
-	-	1	-	B	690501-4	CAM, POST-FEED 1 5/8 ST	47
1	1	1	-	B	459456-1	APPLICATOR, BASIC (SUBASSY)	46
1	1	1	-	A	690191-1	PLUG, NYLON	45
1	1	1	-	C	455673-1	RAM	44
1	1	1	-	A	690125-1	WASHER, LAMINATED	43
1	1	1	-	A	690124-1	WASHER, RAM	42
1	1	1	-	A	7-21002-9	BOLT, CRIMPER (5/16x1.00)	41
							40
							39
1	1	1	-	A	690223-2	SPACER, INSULATION DISC	38
1	1	1	-	D	354777-1	WIRE DISC, PLASTIC	37
1	1	1	-	A	22480-5	WASHER, SPRING	36
1	1	1	-	B	690212-1	POST, RAM	35
1	1	1	-	B	1-690786-5	SUPPORT, TERMINAL	34
REF	REF	REF	-	D	455675-1	PLATE, BASE	33
							32
							31
REF	REF	REF	-	B	455689-1	BLOCK, STRIP GUIDE ADJ	30
1	1	1	-	C	843761-1	PLATE, ADJ STRIP GUIDE	29
1	1	1	-	C	1-455888-3	SPACER, FRONT SHEAR DEP	28
2	2	2	-	A	1-22284-0	SPRING, DRAG	27
1	1	1	-	B	240793-1	LEVER, DRAG RELEASE	26
1	1	1	-	B	240792-1	DRAG, TERMINAL	25
1	1	1	-	D	4-690440-9	GUIDE, STRIP (REAR)	24
1	1	1	-	A	690438-1	GUIDE, STRIP (FRONT)	23
-	-	1	-	B	690472-2	STRIPPER	22
REF	REF	REF	-	A	4-22284-9	SPRING, FEED RETURN	21
1	1	-	-	A	679218-1	STRIPPER WIRE STOP ASSY	20
1	1	-	-	B	458949-1	STRIPPER	19
							18
							17
1	1	1	-	B	318563-1	GUARD, CHIP, FRONT	16
							15
							14
							13
1	1	1	-	A	5-22280-0	SPRING, SHEAR	12
1	1	1	-	B	690461-1	STOP, SHEAR	11
1	1	1	-	C	690459-1	HOLDER, SHEAR (FRONT)	10
1	1	1	-	C	454276-1	SHEAR, FLOAT (FRONT)	9
1	1	1	-	C	1-904717-0	ANVIL	8
1	1	1	-	C	6-240641-5	SPACER, DEPRESSOR (REAR)	7
							6
							5
1	1	1	-	C	1-455889-4	DEPRESSOR, SHEAR (FRONT)	4
							3
							2
1	1	1	-	C	4-456408-2	CRIMPER, WIRE	1

QTY REQD PER ASSY	TERM APPL	SPEC	FEED	APPL INSTRUCTION	SET UP GAGE	LAYOUT	
-3	-2	-1	U/M	DWG SIZE	PART NO	DESCRIPTION	ITEM NO

THIS DRAWING IS A CONTROLLED DOCUMENT FOR AMP INCORPORATED. IT IS SUBJECT TO CHANGE AND THE CONTROLLING ENGINEERING ORGANIZATION SHOULD BE CONTACTED FOR THE LATEST REVISION.

THIS INFORMATION IS CONFIDENTIAL AND IS DISCLOSED TO YOU ON CONDITION THAT NO FURTHER DISCLOSURE IS MADE BY YOU TO OTHER THAN AMP PERSONNEL WITHOUT WRITTEN AUTHORIZATION FROM AMP INCORPORATED, HARRISBURG, PA.

A  
B  
C  
D  
E  
F  
G  
H