

REVISIONS				
P	LTN	DESCRIPTION	DATE	APVD
A		INITIAL RELEASE	28MAR16	D.Z I.Y
B		REV PER ECR-19-013955	09SEP19	D.Z W.W
B1		ECN-21-124860	03NOV21	A.C I.Y

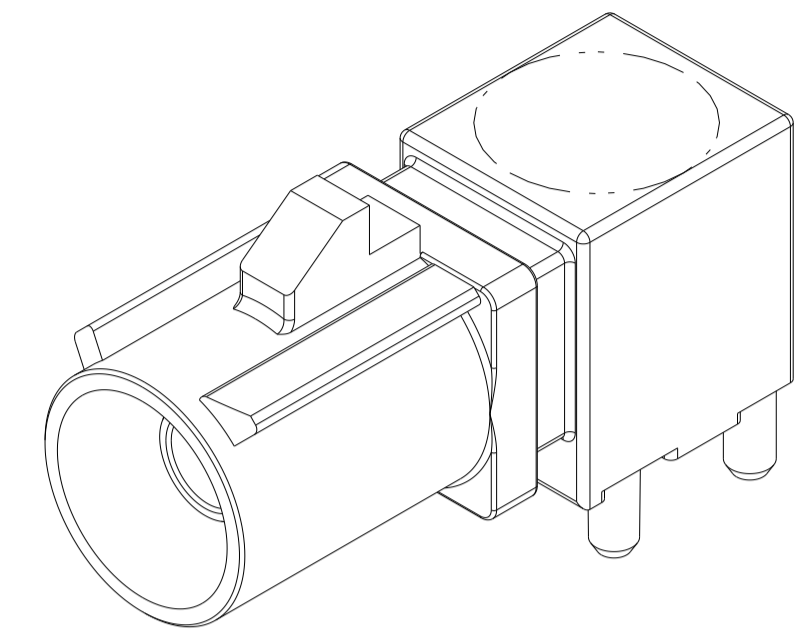

SCALE 5:1

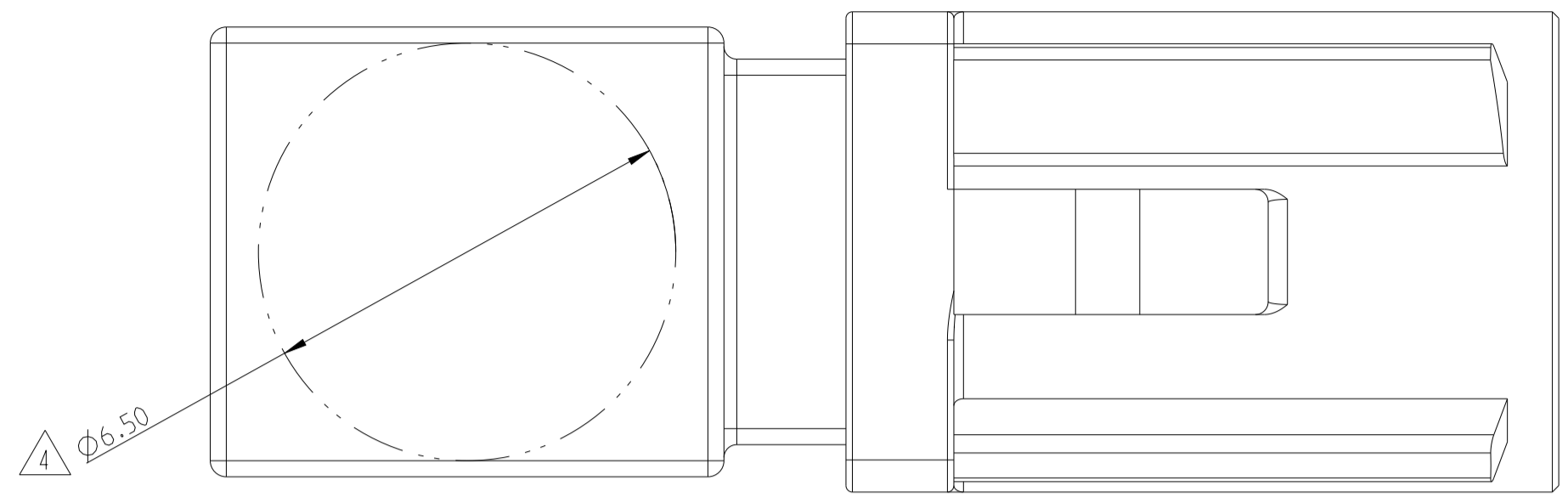
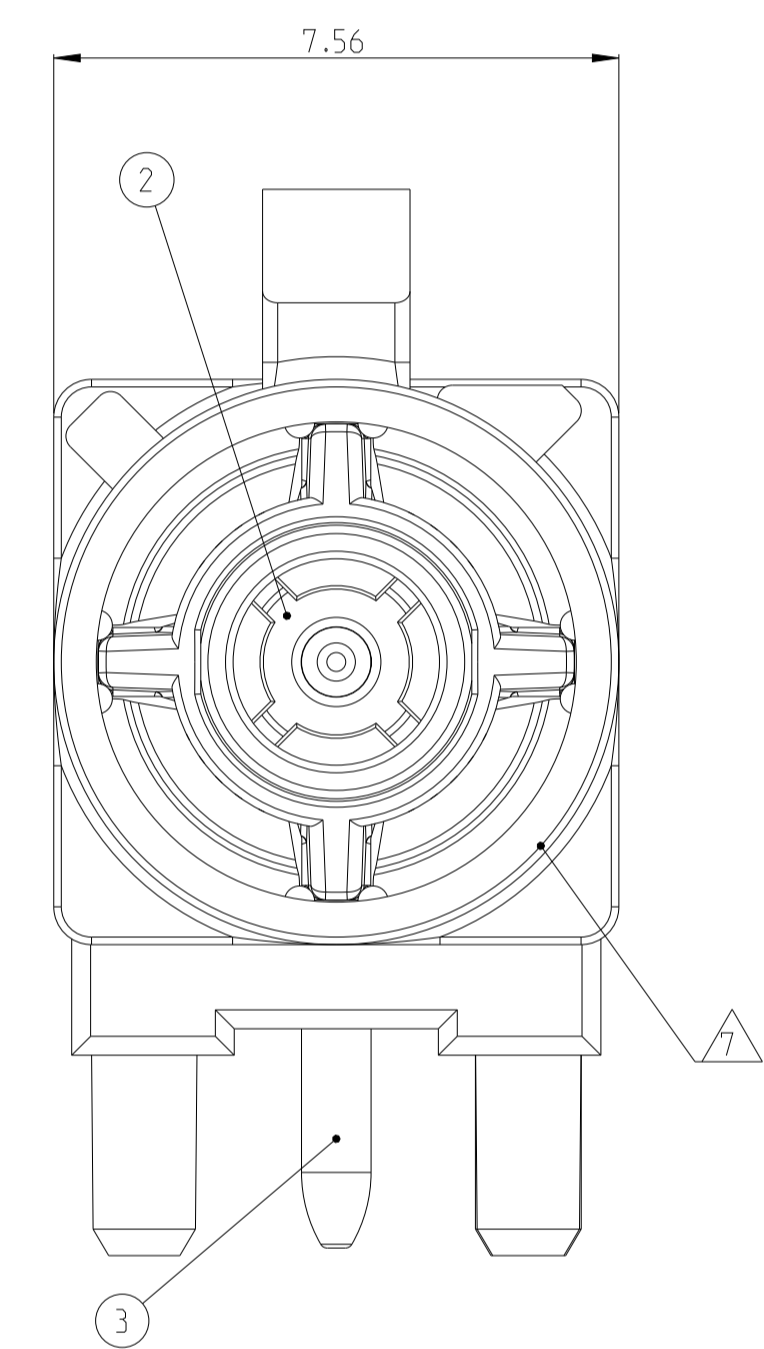
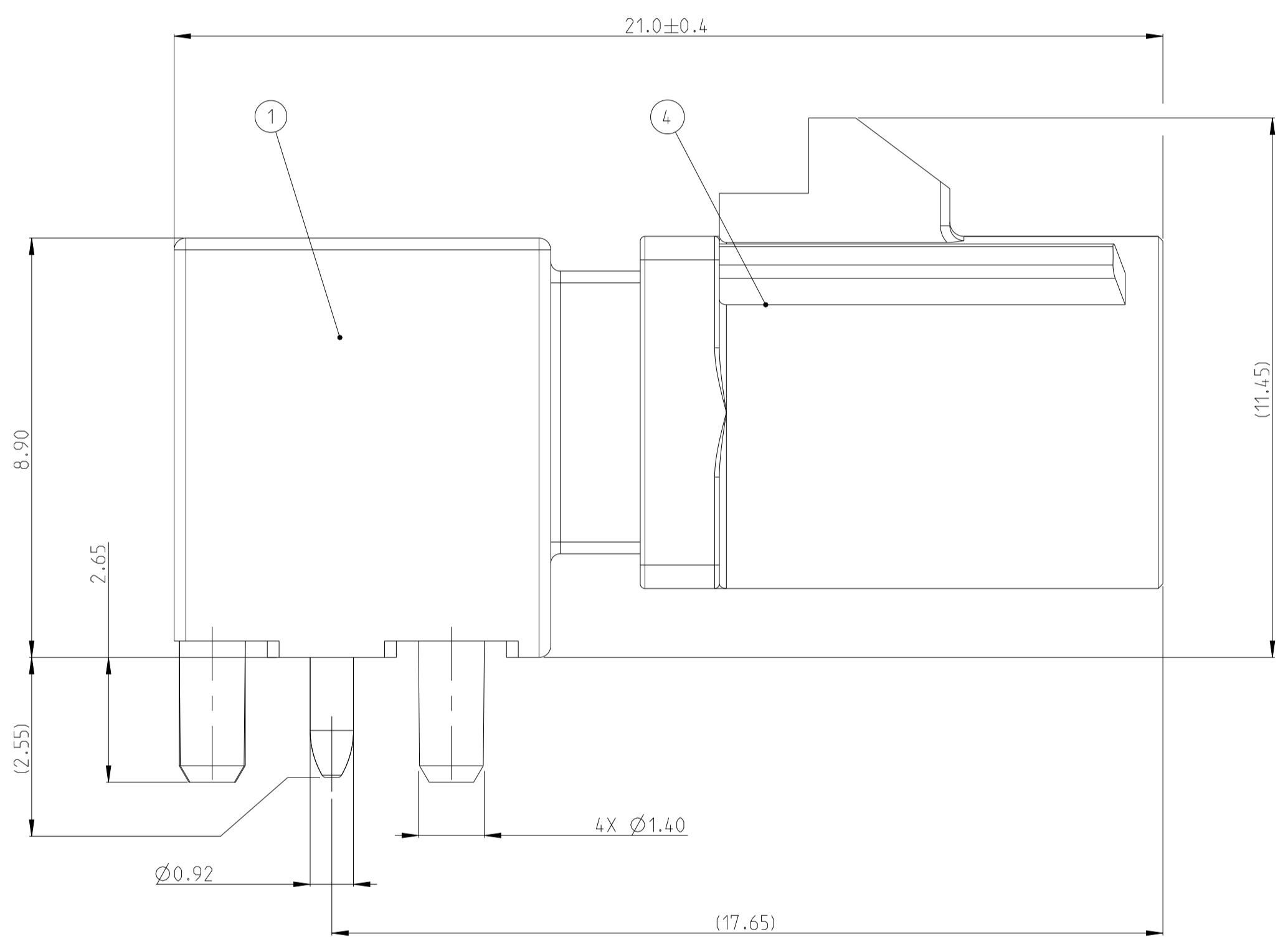

- 1 NOSE CONE - NYLON. COLOR: SEE TABLE. 30% GLASS FILLED.
DIELECTRIC - POLYESTER PCT. NATURAL. 30% GLASS FILLED.
PIN CONTACT - BRASS.
OUTER SHELL - ZINC.
 - 2 PIN CONTACT - 0.38 µm MIN GOLD ON INTERFACE END.
2.5 µm MIN TIN ON SOLDER END.
BOTH OVER 1.3 µm MIN NICKEL.
OUTER SHELL - 2.0 µm MIN TIN OVER 1.52 µm MIN NICKEL.
BOTH OVER 2.54 µm MIN COPPER.
 - 3 MASS = 3.94g (REFERENCE)
 - 4 VACUUM PICKUP AREA.
 - 5 MINIMUM RECOMMENDED GROUND PLANE.
 - 6 SIGNAL DIMENSION TRACE RECOMMENDED FOR OPTIMUM SIGNAL PERFORMANCE.
 - 7 MALE INTERFACE PER ISO-20860-1. ROAD VEHICLES 50 Ohm RADIO FREQUENCY INTERFACE.
- 8 PACKAGING: TAPE AND REEL.

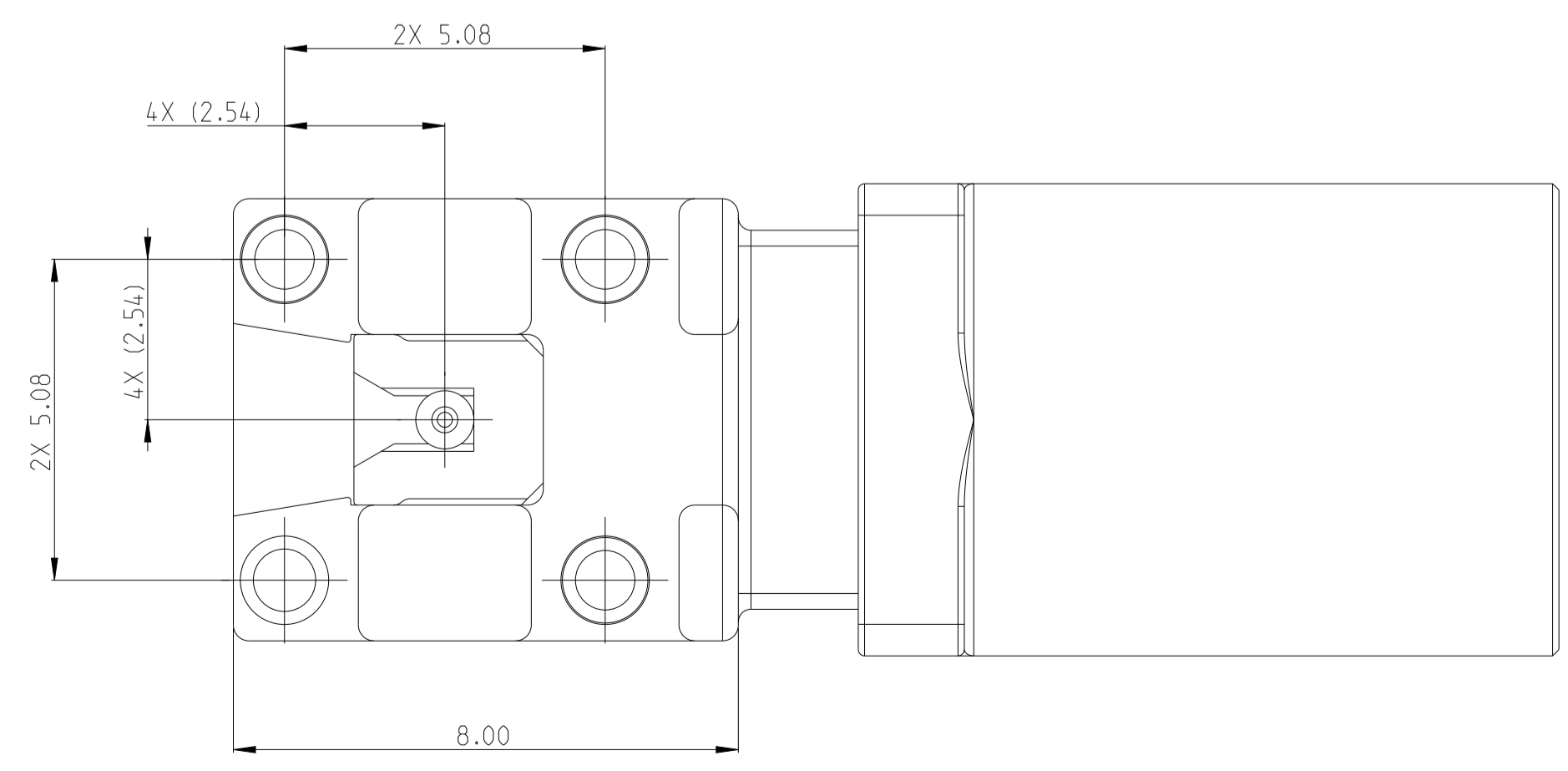

PER DETAIL Z	WATER BLUE	MATERIAL BRASS	MATERIAL PCT	MATERIAL ZINC ALLOY	Z	2-2291392-0
PER DETAIL N	PASTEL GREEN				N	1-2291392-3
PER DETAIL M	PASTEL ORANGE				M	1-2291392-2
PER DETAIL L	CARMINE RED				L	1-2291392-1
PER DETAIL K	CURRY				K	1-2291392-0
PER DETAIL I	BEIGE				I	2291392-9
PER DETAIL H	HEATHER VIOLET				H	2291392-8
PER DETAIL G	BLUE GREY				G	2291392-7
PER DETAIL F	NUT BROWN				F	2291392-6
PER DETAIL E	LEAF GREEN				E	2291392-5
PER DETAIL D	CLARET VIOLET				D	2291392-4
PER DETAIL C	SIGNAL BLUE				C	2291392-3
PER DETAIL B	CREAM				B	2291392-2
PER DETAIL A	JET BLACK				A	2291392-1
CODING DETAIL	4 NOSE CONE COLOR	3 CENTER PIN	2 DIELECTRIC	1 DIE CASTING	CODING REF	PART NUMBER

THIS DRAWING IS A CONTROLLED DOCUMENT. DWG: A.CAI 03NOV2021
 CHK: C.PAN 03NOV2021
 APVD: I.YIN 03NOV2021

STE TE Connectivity

NAME: MALE ASSEMBLY, STANDOFF
 1 POSITION, PCB, FAKRA

SIZE: A1 CAGE CODE: 00779 DRAWING NO: 108-32058
 WEIGHT: - RESTRICTED TO: -
 CUSTOMER DRAWING SCALE: 10:1 SHEET: 1 OF 2 REV: B1

REVISIONS				
P	LTN	DESCRIPTION	DATE	APVD
-	-	SEE SHEET 1	-	-

CODINGS

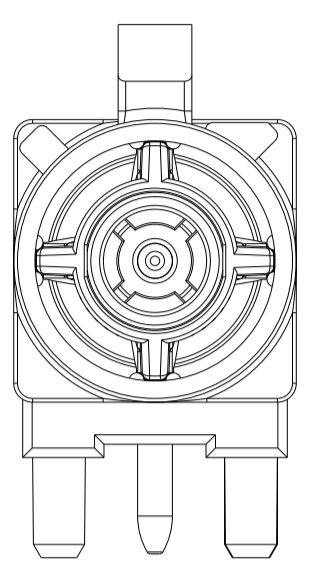

DETAIL A
SCALE 5:1

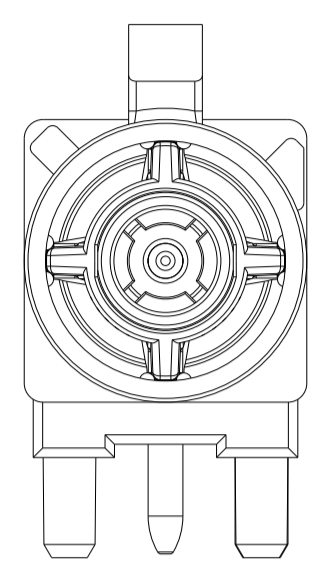

DETAIL B
SCALE 5:1

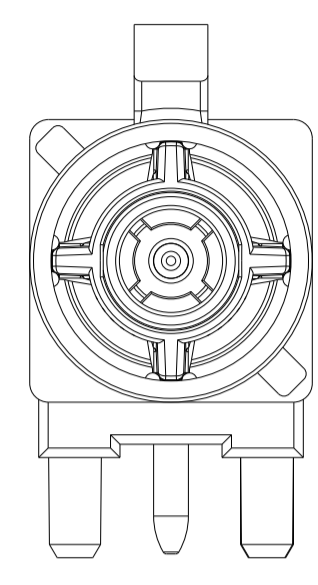

DETAIL C
SCALE 5:1

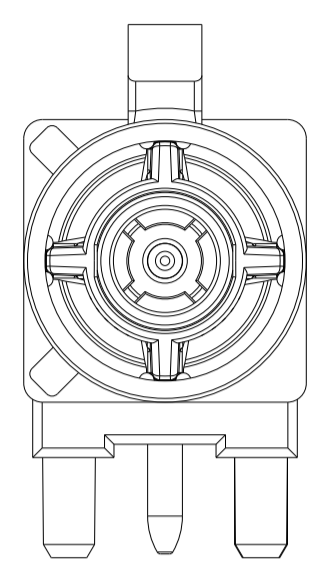

DETAIL D
SCALE 5:1

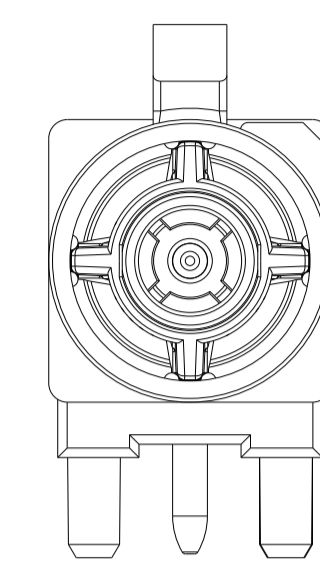

DETAIL E
SCALE 5:1

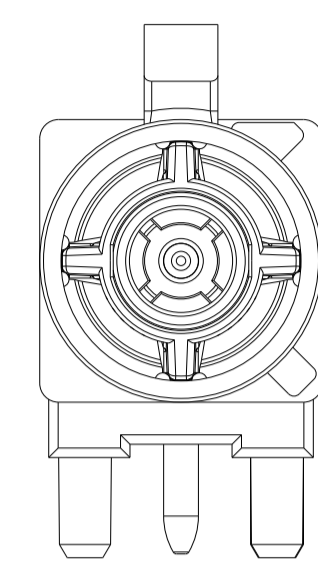

DETAIL F
SCALE 5:1

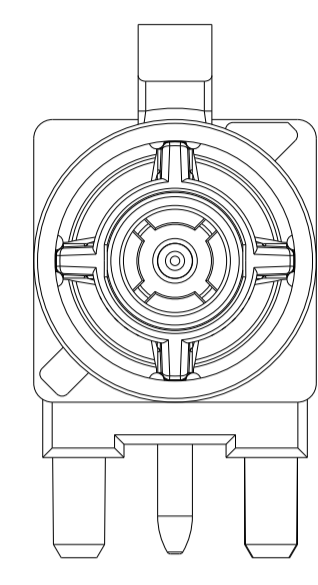

DETAIL G
SCALE 5:1

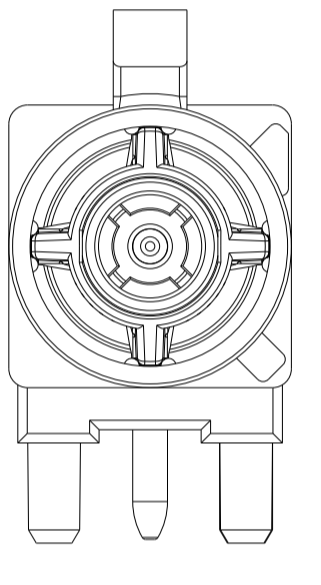

DETAIL H
SCALE 5:1

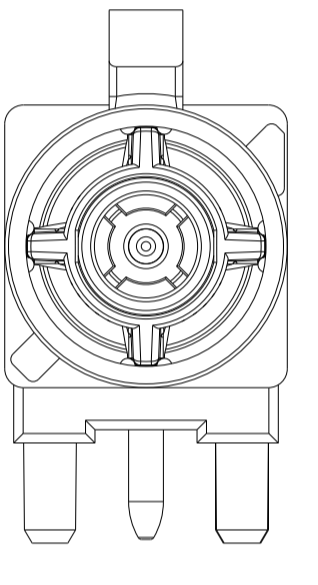

DETAIL I
SCALE 5:1

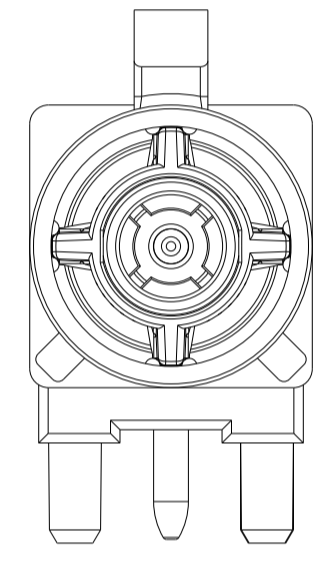

DETAIL K
SCALE 5:1

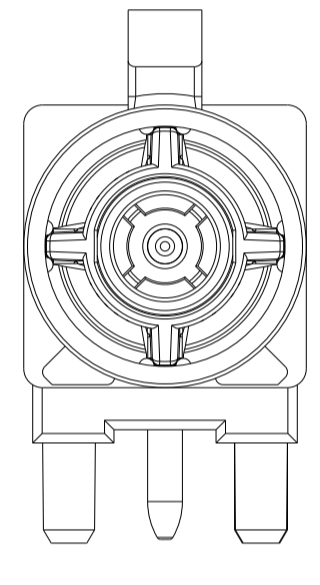

DETAIL L
SCALE 5:1

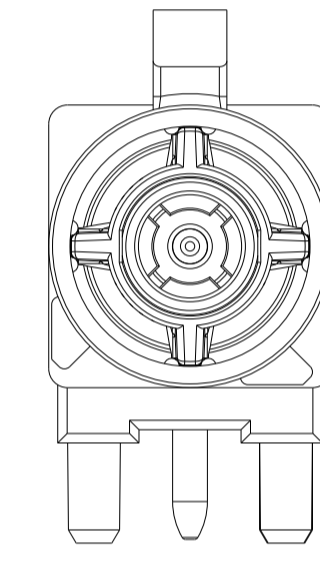

DETAIL M
SCALE 5:1

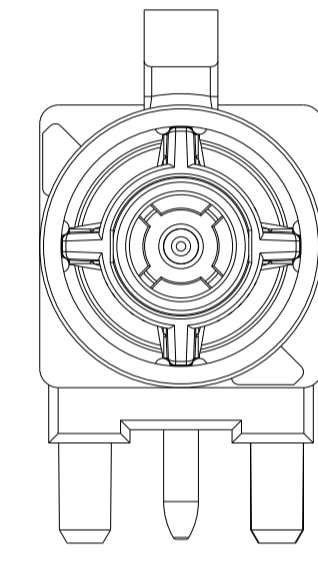

DETAIL N
SCALE 5:1

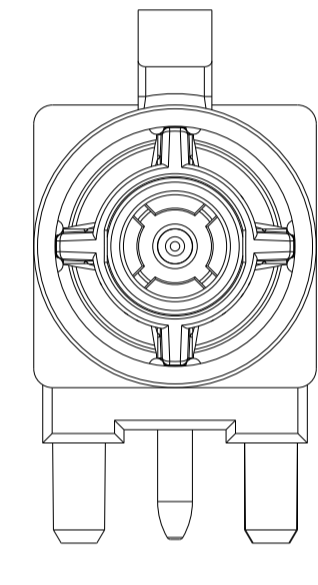

DETAIL Z
SCALE 5:1

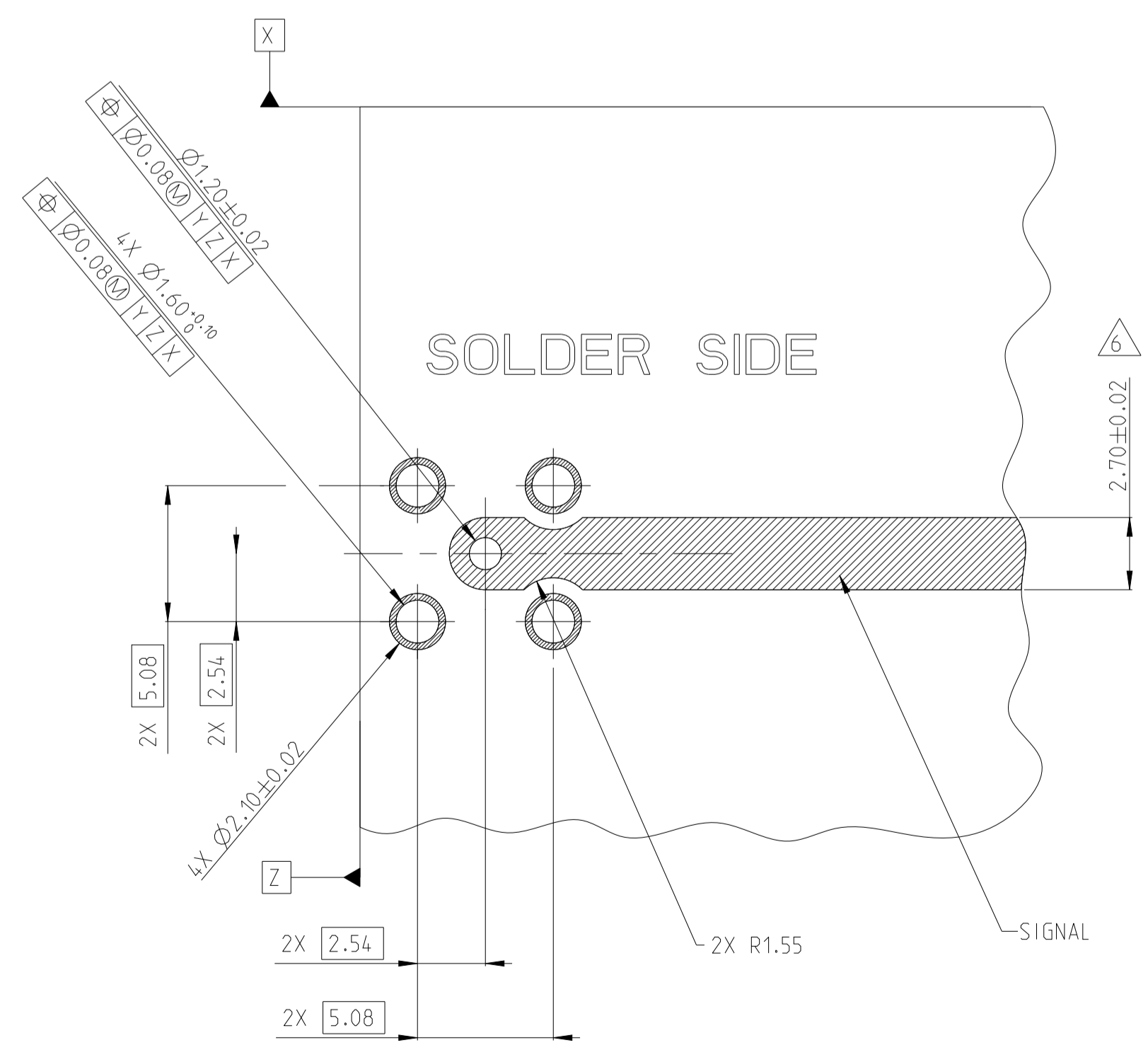

SCALE 5:1

DETAIL A
SCALE 40:1

△ MATERIAL DIELECTRIC CONSTANT; FR4 = 4.51

THIS DRAWING IS A CONTROLLED DOCUMENT.		DWN: A_CAI	03NOV2021	TE Connectivity
DIMENSIONS: mm		CHK: C_PAN	03NOV2021	
TOLERANCES UNLESS OTHERWISE SPECIFIED:		APVD: LYJIN	03NOV2021	NAME: MALE ASSEMBLY, STANDOFF 1 POSITION, PCB, FAKRA
0 PLC ± 1 PLC ±0.3 2 PLC ±0.20 3 PLC ± 4 PLC ± ANGLES ± FINISH ±		PRODUCT SPEC	APPLICATION SPEC	
MATERIAL		SIZE: A1	CAGE CODE: 00779	DRAWING NO: C=2291392
CUSTOMER DRAWING		SCALE: 6:1	SHEET: 2 OF 2	REV: B1