

REVISONS		DATE	BY	APPV
NO	DESCRIPTION			
J	REV PER ECO-15-005911	20MAY15	KG	DM

- ⚠ MARKED WITH .047 [1.19] HIGH CHARACTERS. FAR SIDE REFERS TO WIDE SIDE OF KEYSTONE. NEAR SIDE REFERS TO NARROW SIDE OF KEYSTONE.
- ⚠ RUBBER GROMMET APPLIES ONLY FOR 1218235-6 THRU 1-1218235-0 AND 2-1218235-6 THRU 3-1218235-0.
- 3. BERYLLIUM COPPER RETENTION CLIPS ARE INCLUDED IN INSERTS.
- 4. CONTACTS NOT SUPPLIED. MUST BE ORDERED SEPARTELY. WILL ACCOMMODATE A SIZE 20 PIN CONTACT PER MIL-C-39029/64-369 OR NASA G-10-P1. CONTACT TE ENGINEERING FOR ANY OTHER CONTACT STYLES.
- 5. THIS PLUG WILL MATE WITH ANY RECEPTACLE CONNECTOR WITH THE SAME INSERT ARRANGEMENT.
- 6. MAXIMUM WIRE INSULATION USED WITH THIS CONNECTOR IS .072 [1.83] DIAMETER WITH GROMMET, .084 [2.13] WITHOUT GROMMET.
- 7. UNLESS OTHERWISE STATED THIS ASSEMBLY CONFORMS TO MIL-PRF-24308.
- ⚠ ELECTROLESS NICKEL UNDERPLATE DOES NOT CONTAIN INTENTIONAL ADDITIONS OF LEAD AND CADMIUM PER DFE STANDARD 230-700.
- ⚠ SPECIAL TESTING PER RAYTHEON R10006242 SPECIFICATION.

CUSTOMER PART NO.	L	J	H	E	D	C	B	A	REMARKS	NO OF POSN.	SHELL SIZE	PART NUMBER
R10006242-0044	.039 [0.99]	.550 [13.97]	2.189 [55.60]	.605 [15.38]	.423 [10.74]	2.406 [61.11]	2.064 [52.43]	2.635 [66.93]	⚠	50	5	3-1218235-0
R10006242-0043	.039 [0.99]	.438 [11.13]	2.284 [58.01]	.494 [12.55]	.311 [7.90]	2.500 [63.50]	2.159 [54.84]	2.729 [69.32]	⚠	37	4	2-1218235-9
R10006242-0042	.039 [0.99]	.438 [11.13]	1.636 [41.55]	.494 [12.55]	.311 [7.90]	1.852 [47.04]	1.511 [38.38]	2.088 [53.04]	⚠	25	3	2-1218235-8
R10006242-0041	.030 [0.76]	.438 [11.13]	1.094 [27.79]	.494 [12.55]	.311 [7.90]	1.312 [33.32]	.971 [24.66]	1.541 [39.14]	⚠	15	2	2-1218235-7
R10006242-0040	.030 [0.76]	.438 [11.13]	.770 [19.56]	.494 [12.55]	.311 [7.90]	.984 [24.99]	.643 [16.33]	1.213 [30.81]	⚠	9	1	2-1218235-6
R10006242-0039	.039 [0.99]	.550 [13.97]	2.189 [55.60]	.605 [15.38]	.423 [10.74]	2.406 [61.11]	2.064 [52.43]	2.635 [66.93]	⚠	50	5	2-1218235-5
R10006242-0038	.039 [0.99]	.438 [11.13]	2.284 [58.01]	.494 [12.55]	.311 [7.90]	2.500 [63.50]	2.159 [54.84]	2.729 [69.32]	⚠	37	4	2-1218235-4
R10006242-0037	.039 [0.99]	.438 [11.13]	1.636 [41.55]	.494 [12.55]	.311 [7.90]	1.852 [47.04]	1.511 [38.38]	2.088 [53.04]	⚠	25	3	2-1218235-3
R10006242-0036	.030 [0.76]	.438 [11.13]	1.094 [27.79]	.494 [12.55]	.311 [7.90]	1.312 [33.32]	.971 [24.66]	1.541 [39.14]	⚠	15	2	2-1218235-2
R10006242-0035	.030 [0.76]	.438 [11.13]	.770 [19.56]	.494 [12.55]	.311 [7.90]	.984 [24.99]	.643 [16.33]	1.213 [30.81]	⚠	9	1	2-1218235-1
OBSOLETE	---	.039 [0.99]	.550 [13.97]	2.189 [55.60]	.605 [15.38]	.423 [10.74]	2.406 [61.11]	2.064 [52.43]	⚠	50	5	5-1218235-5
OBSOLETE	---	.030 [0.76]	.438 [11.13]	1.094 [27.79]	.494 [12.55]	.311 [7.90]	1.312 [33.32]	.971 [24.66]	⚠	15	2	5-1218235-2
---	---	.039 [0.99]	.550 [13.97]	2.189 [55.60]	.605 [15.38]	.423 [10.74]	2.406 [61.11]	2.064 [52.43]	⚠	50	5	1-1218235-0
---	---	.039 [0.99]	.438 [11.13]	2.284 [58.01]	.494 [12.55]	.311 [7.90]	2.500 [63.50]	2.159 [54.84]	⚠	37	4	1218235-9
---	---	.039 [0.99]	.438 [11.13]	1.636 [41.55]	.494 [12.55]	.311 [7.90]	1.852 [47.04]	1.511 [38.38]	⚠	25	3	1218235-8
---	---	.030 [0.76]	.438 [11.13]	1.094 [27.79]	.494 [12.55]	.311 [7.90]	1.312 [33.32]	.971 [24.66]	⚠	15	2	1218235-7
---	---	.030 [0.76]	.438 [11.13]	.770 [19.56]	.494 [12.55]	.311 [7.90]	.984 [24.99]	.643 [16.33]	⚠	9	1	1218235-6
---	---	.039 [0.99]	.550 [13.97]	2.189 [55.60]	.605 [15.38]	.423 [10.74]	2.406 [61.11]	2.064 [52.43]	-	50	5	1218235-5
---	---	.039 [0.99]	.438 [11.13]	2.284 [58.01]	.494 [12.55]	.311 [7.90]	2.500 [63.50]	2.159 [54.84]	-	37	4	1218235-4
---	---	.039 [0.99]	.438 [11.13]	1.636 [41.55]	.494 [12.55]	.311 [7.90]	1.852 [47.04]	1.511 [38.38]	-	25	3	1218235-3
---	---	.030 [0.76]	.438 [11.13]	1.094 [27.79]	.494 [12.55]	.311 [7.90]	1.312 [33.32]	.971 [24.66]	-	15	2	1218235-2
---	---	.030 [0.76]	.438 [11.13]	.770 [19.56]	.494 [12.55]	.311 [7.90]	.984 [24.99]	.643 [16.33]	-	9	1	1218235-1

THIS DRAWING IS A CONTROLLED DOCUMENT.

DIMENSIONS: INCHES [mm]	TOLERANCES UNLESS OTHERWISE SPECIFIED:	DIN C.C.THOMAS 28-APR-90	APPROVED: J.NORTON 07-MAY-90
0 PLC ± -	1 PLC ± -	2 PLC ± -	3 PLC ± -
4 PLC ± -	ANGLES ± -	FINISH -	WEIGHT -

RECEPTACLE ASSEMBLY, AMPLIMITE ULTRA-LITE, SERIES 109, SIZE 1 THRU 5 (ONE PIECE ALUMINUM SHELL)

SCALE 4:1 SHEET 1 OF 2 REV J

LOC		DIST		REVISIONS			
P	LTR	DESCRIPTION	DATE	DNW	APVD		
-	-	SEE SHEET 1	-	-	-	-	-

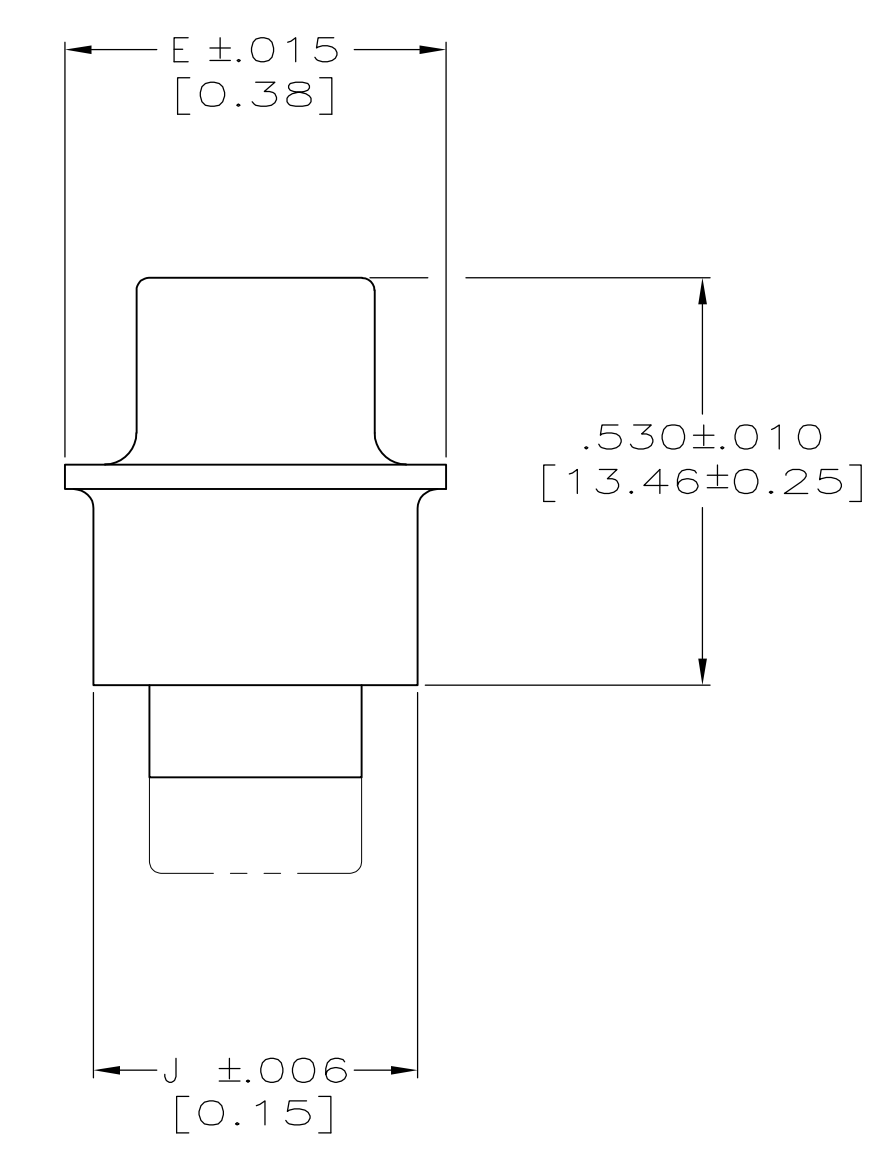
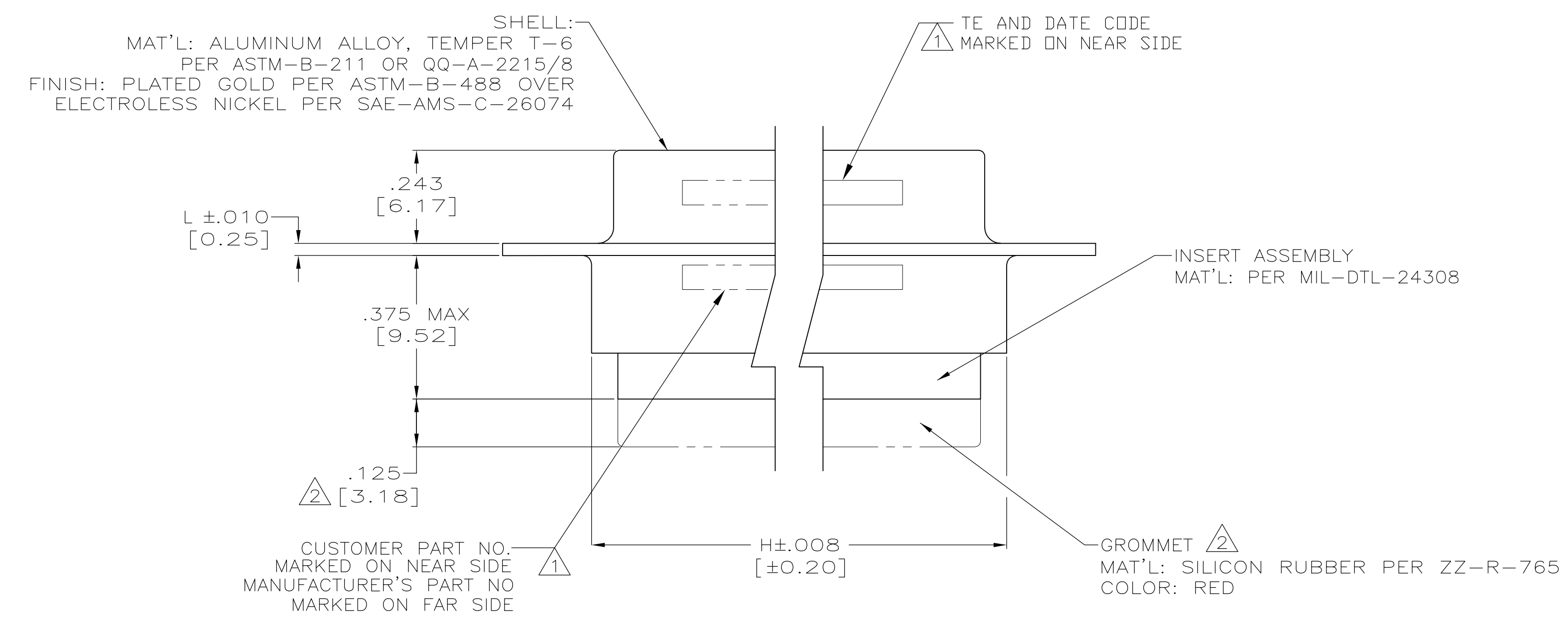
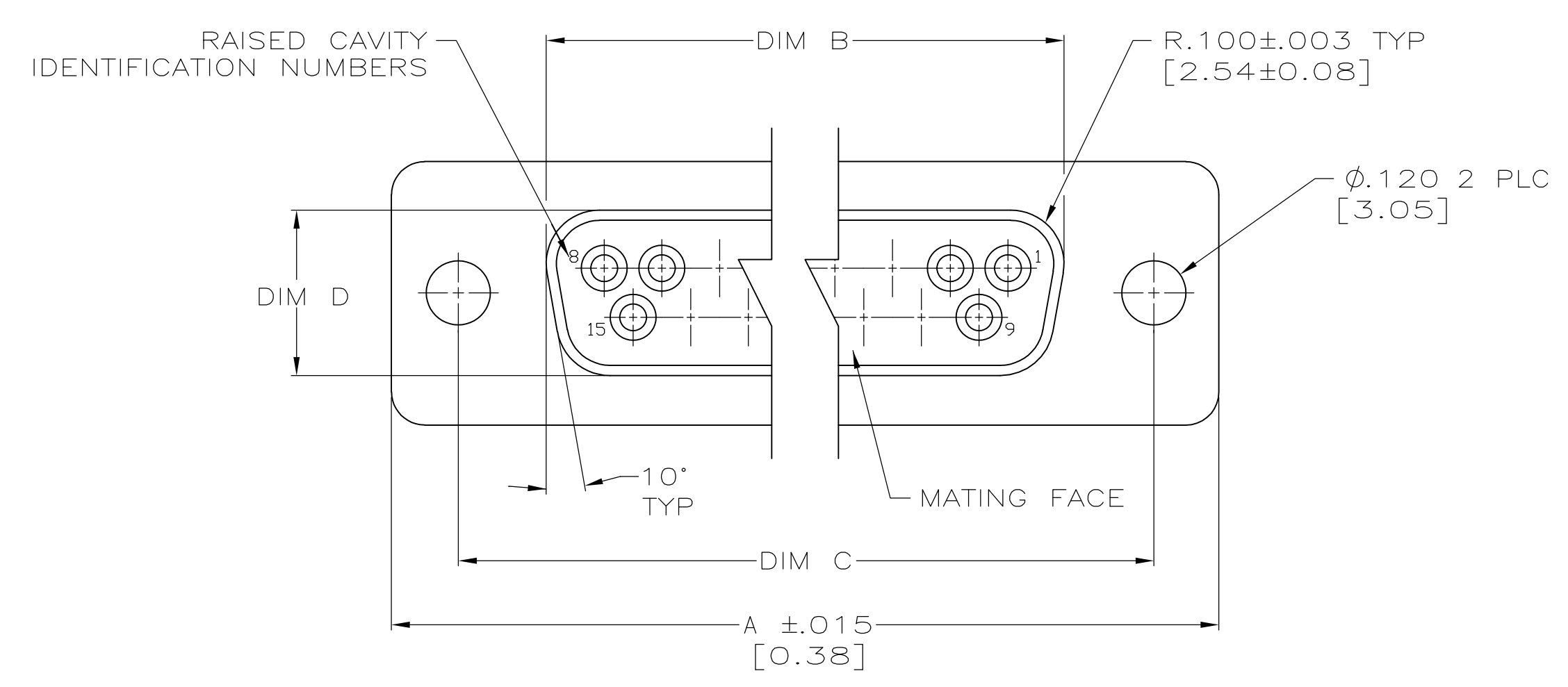

THIS DRAWING IS A CONTROLLED DOCUMENT.		DIN C.C.THOMAS 28-APR-90	TE Connectivity
DIMENSIONS: INCHES [mm]		CHK J.NORTON 07-MAY-90	
	TOLERANCES UNLESS OTHERWISE SPECIFIED:	APVD J.NORTON 07-MAY-90	NAME
	0 PLC ± -	PRODUCT SPEC	RECEPTACLE ASSEMBLY, AMPLIMITE
	1 PLC ± -	APPLICATION SPEC	ULTRA-LITE, SERIES 109, SIZE 1 THRU 5
	2 PLC ± -	SIZE	(ONE PIECE ALUMINUM SHELL)
3 PLC ± .005(0.13)	WEIGHT	A1 00779	DRAWING NO
4 PLC ± -	CUSTOMER DRAWING	1218235	RESTRICTED TO
ANGLES ± -	SCALE 4:1	SHEET 2 OF 2	REV J