

Low Power Clock for ATI RS/RD600 series chipsets for AMD CPUs

ICS9LPRS462

Description

ATI RD/RS600 series systems using AMD CPUs

Output Features

- Integrated Series Resistors on differential outputs
- Greyhound Compatible CPU outputs
- 2 - 0.7V Low Power differential CPU pairs
- 8 - 0.7V Low Power differential SRC pairs
- 4 - 0.7V Low Power differential ATIG pairs
- 1 - 66 MHz HyperTransport clock
- 2 - 48MHz USB clocks
- 3 - 14.318MHz Reference clocks

Features/Benefits:

- 3 - Programmable Clock Request pins for SRC and ATIG clocks
- ATIGCLKs are programmable for frequency
- Spread Spectrum for EMI reduction
- Outputs may be disabled via SMBus
- External crystal load capacitors for maximum frequency accuracy

Key Specifications

- CPU outputs cycle-to-cycle jitter <150ps
- SRC outputs cycle-to-cycle jitter < 125ps
- ATIG outputs cycle-to-cycle jitter < 125ps
- +/- 100ppm frequency accuracy on all outputs if REF is tuned to +/-100ppm

Pin Configuration

GNDREF	1	64	FS0/REF0
VDDREF	2	63	FS1/REF1
X1	3	62	FS2/REF2
X2	4	61	**PD
VDD48	5	60	VDDHTT
48MHz_0	6	59	HTTCLK0
48MHz_1	7	58	GNDHTT
GND48	8	57	*CLKREQA#
SMBCLK	9	56	CPUKG0T_LPR
SMBDAT	10	55	CPUKG0C_LPR
RESET_IN#	11	54	VDDCPU
SRC7T_LPR	12	53	GNDCPU
SRC7C_LPR	13	52	CPUKG1T_LPR
VDDSRC	14	51	CPUKG1C_LPR
GNDSRC	15	50	VDDA
SRC6T_LPR	16	49	GNDA
SRC6C_LPR	17	48	NC
SRC5T_LPR	18	47	SRC0T_LPR
SRC5C_LPR	19	46	SRC0C_LPR
SRC4T_LPR	20	45	GNDSRC
SRC4C_LPR	21	44	VDDSRC
GNDSRC	22	43	SRC1T_LPR
VDDSRC	23	42	SRC1C_LPR
SRC3T_LPR	24	41	ATIG0T_LPR
SRC3C_LPR	25	40	ATIG0C_LPR
SRC2T_LPR	26	39	VDDATIG
SRC2C_LPR	27	38	GNDATIG
VDDSRC	28	37	ATIG1T_LPR
GNDSRC	29	36	ATIG1C_LPR
ATIG3T_LPR	30	35	ATIG2T_LPR
ATIG3C_LPR	31	34	ATIG2C_LPR
*CLKREQB#	32	33	*CLKREQC#

9LPRS462

64-TSSOP

- * Internal Pull-Up Resistor
- ** Internal Pull-Down Resistor

Funtionality

FS2	FS1	FS0	CPU MHz	HTT MHz	SRC MHz	ATIG MHz	USB MHz
0	0	0	Hi-Z	Hi-Z	100.00	100.00	48.00
0	0	1	X / 2	X / 3	100.00	100.00	48.00
0	1	0	230.00	76.67	100.00	100.00	48.00
0	1	1	240.00	80.00	100.00	100.00	48.00
1	0	0	100.00	66.66	100.00	100.00	48.00
1	0	1	133.33	66.66	100.00	100.00	48.00
1	1	0	166.67	66.66	100.00	100.00	48.00
1	1	1	200.00	66.66	100.00	100.00	48.00

Power Groups

Pin Number		Description
VDD	GND	
5	8	USB_48 outputs
14,23,26,36	15,22,27,37	SRCCLK outputs
33	32	ATIGCLK differential outputs
42	41	Analog, PLL
46	45	CPUCLK8 differential outputs
52	50	HTTCLK output
2	1	REF outputs

Pin Description

PIN #	PIN NAME	TYPE	DESCRIPTION
1	GNDREF	GND	Ground pin for the REF outputs.
2	VDDREF	PWR	Ref, XTAL power supply, nominal 3.3V
3	X1	IN	Crystal input, nominally 14.318MHz
4	X2	OUT	Crystal output, nominally 14.318MHz
5	VDD48	PWR	Power pin for the 48MHz outputs and core. 3.3V
6	48MHz_0	OUT	48MHz clock output.
7	48MHz_1	OUT	48MHz clock output.
8	GND48	GND	Ground pin for the 48MHz outputs
9	SMBCLK	IN	Clock pin of SMBus circuitry, 5V tolerant.
10	SMBDAT	I/O	Data pin for SMBus circuitry, 5V tolerant.
11	RESET_IN#	IN	Real Time falling edge triggered input. When asserted, the part initiates a power up reset with the SMBus being reset to its power up values, and all PLL derived clocks stopped for the duration of Power up Stabilization. REF outputs continue to run.
12	SRC7T_LPR	OUT	True clock of low power differential SRC clock pair with integrated 33 ohm series resistor. (no 50ohm shunt resistor to GND needed)
13	SRC7C_LPR	OUT	Complement clock of low power differential SRC clock pair with integrated 33 ohm series resistor. (no 50ohm shunt resistor to GND needed)
14	VDDSRC	PWR	Supply for SRC, 3.3V nominal
15	GNSRC	GND	Ground pin for the SRC outputs
16	SRC6T_LPR	OUT	True clock of low power differential SRC clock pair with integrated 33 ohm series resistor. (no 50ohm shunt resistor to GND needed)
17	SRC6C_LPR	OUT	Complement clock of low power differential SRC clock pair with integrated 33 ohm series resistor. (no 50ohm shunt resistor to GND needed)
18	SRC5T_LPR	OUT	True clock of low power differential SRC clock pair with integrated 33 ohm series resistor. (no 50ohm shunt resistor to GND needed)
19	SRC5C_LPR	OUT	Complement clock of low power differential SRC clock pair with integrated 33 ohm series resistor. (no 50ohm shunt resistor to GND needed)
20	SRC4T_LPR	OUT	True clock of low power differential SRC clock pair with integrated 33 ohm series resistor. (no 50ohm shunt resistor to GND needed)
21	SRC4C_LPR	OUT	Complement clock of low power differential SRC clock pair with integrated 33 ohm series resistor. (no 50ohm shunt resistor to GND needed)
22	GNSRC	GND	Ground pin for the SRC outputs
23	VDDSRC	PWR	Supply for SRC, 3.3V nominal
24	SRC3T_LPR	OUT	True clock of low power differential SRC clock pair with integrated 33 ohm series resistor. (no 50ohm shunt resistor to GND needed)
25	SRC3C_LPR	OUT	Complement clock of low power differential SRC clock pair with integrated 33 ohm series resistor. (no 50ohm shunt resistor to GND needed)
26	SRC2T_LPR	OUT	True clock of low power differential SRC clock pair with integrated 33 ohm series resistor. (no 50ohm shunt resistor to GND needed)
27	SRC2C_LPR	OUT	Complement clock of low power differential SRC clock pair with integrated 33 ohm series resistor. (no 50ohm shunt resistor to GND needed)
28	VDDSRC	PWR	Supply for SRC, 3.3V nominal
29	GNSRC	GND	Ground pin for the SRC outputs
30	ATIG3T_LPR	OUT	True clock of low-power differential push-pull PCI-Express pair with integrated 33 ohm series resistor. (no 50ohm shunt resistor to GND needed)
31	ATIG3C_LPR	OUT	Complementary clock of low-power differential push-pull PCI-Express pair with integrated 33 ohm series resistor. (no 50ohm shunt resistor to GND needed)
32	*CLKREQB#	IN	Programmable Clock Request pin for SRC/ATIG/SB_SRC outputs. If output is selected for control, then that output is controlled as follows: 0 = Enabled, 1 = Tri-state

Pin Description (Continued)

PIN #	PIN NAME	TYPE	DESCRIPTION
33	*CLKREQC#	IN	Programmable Clock Request pin for SRC/ATIG/SB_SRC outputs. If output is selected for control, then that output is controlled as follows: 0 = Enabled, 1 = Tri-state
34	ATIG2C_LPR	OUT	Complementary clock of low-power differential push-pull PCI-Express pair with integrated 33 ohm series resistor. (no 50ohm shunt resistor to GND needed)
35	ATIG2T_LPR	OUT	True clock of low-power differential push-pull PCI-Express pair with integrated 33 ohm series resistor. (no 50ohm shunt resistor to GND needed)
36	ATIG1C_LPR	OUT	Complementary clock of low-power differential push-pull PCI-Express pair with integrated 33 ohm series resistor. (no 50ohm shunt resistor to GND needed)
37	ATIG1T_LPR	OUT	True clock of low-power differential push-pull PCI-Express pair with integrated 33 ohm series resistor. (no 50ohm shunt resistor to GND needed)
38	GNDATIG	GND	Ground pin for the ATIG outputs
39	VDDATIG	PWR	Power supply for ATIG core, nominal 3.3V
40	ATIG0C_LPR	OUT	Complementary clock of low-power differential push-pull PCI-Express pair with integrated 33 ohm series resistor. (no 50ohm shunt resistor to GND needed)
41	ATIG0T_LPR	OUT	True clock of low-power differential push-pull PCI-Express pair with integrated 33 ohm series resistor. (no 50ohm shunt resistor to GND needed)
42	SRC1C_LPR	OUT	Complement clock of low power differential SRC clock pair with integrated 33 ohm series resistor. (no 50ohm shunt resistor to GND needed)
43	SRC1T_LPR	OUT	True clock of low power differential SRC clock pair with integrated 33 ohm series resistor. (no 50ohm shunt resistor to GND needed)
44	VDDSRC	PWR	Supply for SRC, 3.3V nominal
45	GNDSRC	GND	Ground pin for the SRC outputs
46	SRC0C_LPR	OUT	Complement clock of low power differential SRC clock pair with integrated 33 ohm series resistor. (no 50ohm shunt resistor to GND needed)
47	SRC0T_LPR	OUT	True clock of low power differential SRC clock pair with integrated 33 ohm series resistor. (no 50ohm shunt resistor to GND needed)
48	NC	NC	No Connect
49	GNDA	GND	Ground for the Analog Core
50	VDDA	PWR	3.3V Power for the Analog Core
51	CPUKG1C_LPR	OUT	Complementary signal of low-power differential push-pull AMD K8 "Greyhound" clock with integrated 33 ohm series resistor. (no 50ohm shunt resistor to GND needed)
52	CPUKG1T_LPR	OUT	True signal of low-power differential push-pull AMD K8 "Greyhound" clock with integrated 33 ohm series resistor. (no 50ohm shunt resistor to GND needed)
53	GNDCPU	GND	Ground pin for the CPU outputs
54	VDDCPU	PWR	Supply for CPU, 3.3V nominal
55	CPUKG0C_LPR	OUT	Complementary signal of low-power differential push-pull AMD K8 "Greyhound" clock with integrated 33 ohm series resistor. (no 50ohm shunt resistor to GND needed)
56	CPUKG0T_LPR	OUT	True signal of low-power differential push-pull AMD K8 "Greyhound" clock with integrated 33 ohm series resistor. (no 50ohm shunt resistor to GND needed)
57	*CLKREQA#	IN	Programmable Clock Request pin for SRC/ATIG/SB_SRC outputs. If output is selected for control, then that output is controlled as follows: 0 = Enabled, 1 = Tri-state
58	GNDHTT	PWR	Ground pin for the HTT outputs
59	HTTCLK0	OUT	3.3V single ended 66MHz hyper transport clock
60	VDDHTT	PWR	Supply for HTT clocks, nominal 3.3V.
61	**PD	IN	Enter /Exit Power Down. 1 = Power Down, 0 = normal operation.
62	FS2/REF2	I/O	Frequency select latch input pin/ 3.3V 14.318MHz reference clock
63	FS1/REF1	I/O	Frequency select latch input pin/ 3.3V 14.318MHz reference clock
64	FS0/REF0	I/O	Frequency select latch input pin/ 3.3V 14.318MHz reference clock

General Description

The ICS9LPRS462 is a main clock synthesizer chip that provides all clocks required for ATI RD/RS600-based systems. An SMBus interface allows full control of the device.

Functional Block Diagram

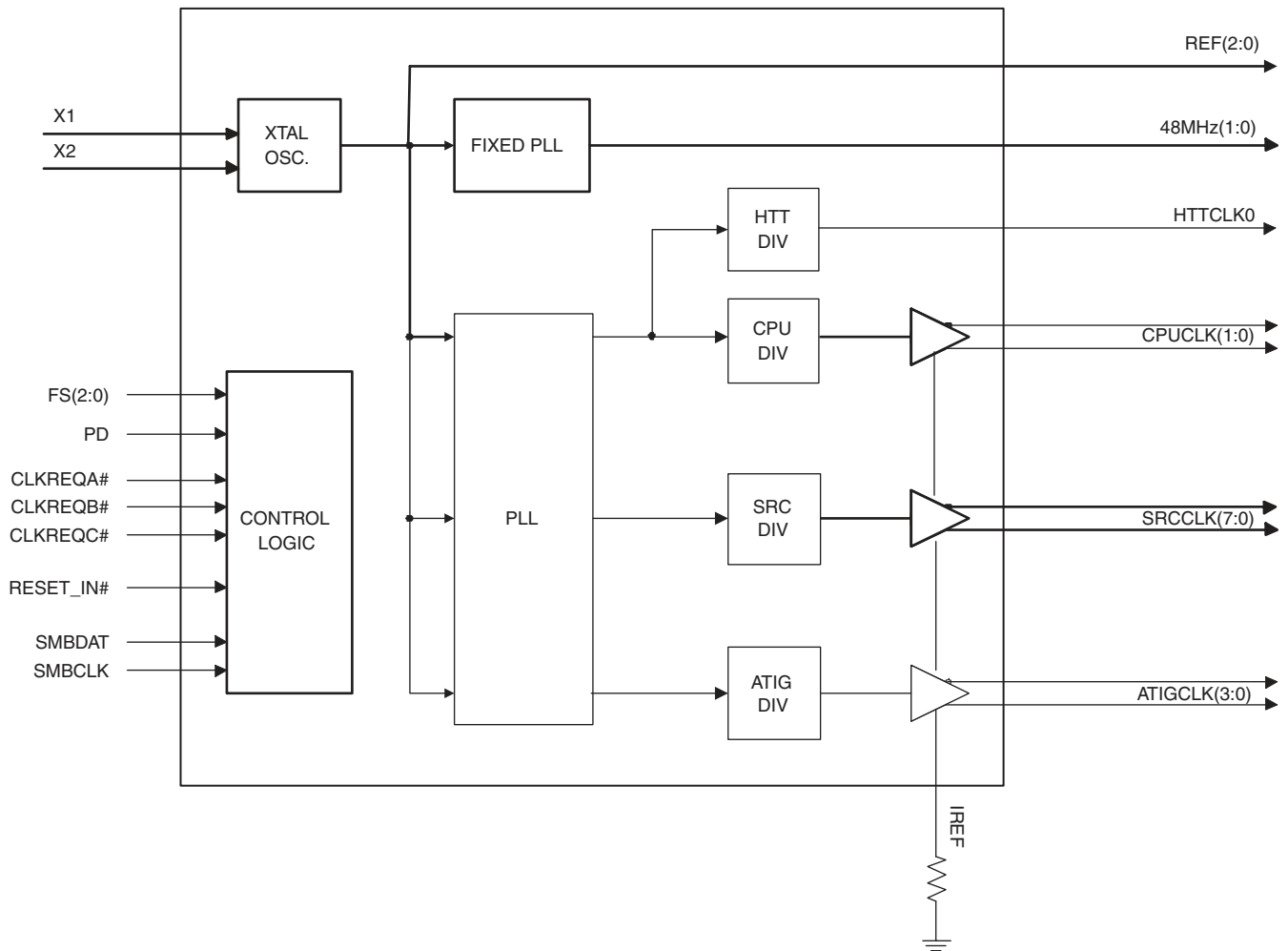

Absolute Max

PARAMETER	SYMBOL	CONDITIONS	MIN	TYP	MAX	UNITS	Notes
3.3V Core Supply Voltage	VDD_A	-			V _{DD} + 0.5V	V	1
3.3V Logic Input Supply Voltage	VDD_In	-	GND - 0.5		V _{DD} + 0.5V	V	1
Storage Temperature	Ts	-	-65		150	°C	1
Ambient Operating Temp	Tambient	-	0		70	°C	1
Case Temperature	Tcase	-			115	°C	1
Input ESD protection HBM	ESD prot	-	2000			V	1

¹Guaranteed by design and characterization, not 100% tested in production.

Electrical Characteristics - Input/Supply/Common Output Parameters

PARAMETER	SYMBOL	CONDITIONS*	MIN	TYP	MAX	UNITS	Notes
Input High Voltage	V _{IH}	3.3 V +/-5%	2		V _{DD} + 0.3	V	1
Input Low Voltage	V _{IL}	3.3 V +/-5%	V _{SS} - 0.3		0.8	V	1
Input High Current	I _{IH}	V _{IN} = V _{DD}	-5		5	uA	1
Input Low Current	I _{IL1}	V _{IN} = 0 V; Inputs with no pull-up resistors	-5			uA	1
	I _{IL2}	V _{IN} = 0 V; Inputs with pull-up resistors	-200			uA	1
Low Threshold Input-High Voltage	V _{IH_FS}	3.3 V +/-5%	0.7		V _{DD} + 0.3	V	1
Low Threshold Input-Low Voltage	V _{IL_FS}	3.3 V +/-5%	V _{SS} - 0.3		0.35	V	1
Operating Current	I _{DD3.30P}	9LPRS462, all outputs driven			200	mA	1
		9LPRS464, all outputs driven			180	mA	1
Powerdown Current	I _{DD3.3PD}	all diff pairs low/low			21	mA	1
Input Frequency	F _i	V _{DD} = 3.3 V		14.31818		MHz	2
Pin Inductance	L _{pin}				7	nH	1
Input Capacitance	C _{IN}	Logic Inputs			5	pF	1
	C _{OUT}	Output pin capacitance			6	pF	1
	C _{INX}	X1 & X2 pins			5	pF	1
Clk Stabilization	T _{STAB}	From VDD Power-Up or de-assertion of PD to 1st clock			1.8	ms	1
Modulation Frequency		Triangular Modulation	30		33	kHz	1
Tdrive_PD		CPU output enable after PD de-assertion			300	us	1
Tfall_PD		PD fall time of			5	ns	1
Trise_PD		PD rise time of			5	ns	1
SMBus Voltage	V _{DD}		2.7		5.5	V	1
Low-level Output Voltage	V _{OL}	@ I _{PULLUP}			0.4	V	1
Current sinking at V _{OL} = 0.4 V	I _{PULLUP}		4			mA	1
SMBCLK/SMBDAT Clock/Data Rise Time	T _{RI2C}	(Max VIL - 0.15) to (Min VIH + 0.15)			1000	ns	1
SMBCLK/SMBDAT Clock/Data Fall Time	T _{FI2C}	(Min VIH + 0.15) to (Max VIL - 0.15)			300	ns	1

*TA = 0 - 70°C; Supply Voltage VDD = 3.3 V +/-5%

¹Guaranteed by design and characterization, not 100% tested in production.

²Input frequency should be measured at the REF pin and tuned to ideal 14.31818MHz to meet ppm frequency accuracy on PLL outputs.

AC Electrical Characteristics - Low-Power DIF Outputs: CPUKG and HTT

PARAMETER	SYMBOL	CONDITIONS	MIN	TYP	MAX	UNITS	NOTES
Crossing Point Variation	ΔV_{CROSS}	Single-ended Measurement			140	mV	1,2,5
Frequency	f	Spread Specturm On	198.8		200	MHz	1,3
Long Term Accuracy	ppm	Spread Specturm Off	-300		+300	ppm	1,11
Rising Edge Slew Rate	S_{RISE}	Differential Measurement	0.5		10	V/ns	1,4
Falling Edge Slew Rate	S_{FALL}	Differential Measurement	0.5		10	V/ns	1,4
Slew Rate Variation	t_{SLVAR}	Single-ended Measurement			20	%	1
CPU, DIF HTT Jitter - Cycle to Cycle	CPUJ_{C2C}	Differential Measurement			150	ps	1,6
Accumulated Jitter	t_{JACC}	See Notes			1	ns	1,7
Peak to Peak Differential Voltage	$V_{\text{D(PK-PK)}}$	Differential Measurement	400		2400	mV	1,8
Differential Voltage	V_{D}	Differential Measurement	200		1200	mV	1,9
Duty Cycle	D_{CYC}	Differential Measurement	45		55	%	1
Amplitude Variation	ΔV_{D}	Change in V_{D} DC cycle to cycle	-75		75	mV	1,10
CPU Skew	$\text{CPU}_{\text{SKEW10}}$	Differential Measurement			100	ps	1

Guaranteed by design and characterization, not 100% tested in production.

Single-ended measurement at crossing point. Value is maximum – minimum over all time. DC value of common mode is not important due to the blocking cap.

Minimum Frequency is a result of 0.5% down spread spectrum

Differential measurement through the range of ± 100 mV, differential signal must remain monotonic and within slew rate spec when crossing through this region.

⁵ Defined as the total variation of all crossing voltages of CLK rising and CLK# falling. Matching applies to rising edge rate of CLK and falling edge of CLK#. It is measured using a ± 75 mV window centered on the average cross point where CLK meets CLK#.

⁶ Max difference of t_{CYCLE} between any two adjacent cycles.

⁷ Accumulated t_{JC} over a 10 μ s time period, measured with JIT2 TIE at 50ps interval.

⁸ $V_{\text{D(PK-PK)}}$ is the overall magnitude of the differential signal.

⁹ $V_{\text{D(min)}}$ is the amplitude of the ring-back differential measurement, guaranteed by design, that ring-back will not cross 0V V_{D} . $V_{\text{D(max)}}$ is the largest amplitude allowed.

¹⁰ The difference in magnitude of two adjacent $V_{\text{D_DC}}$ measurements. $V_{\text{D_DC}}$ is the stable post overshoot and ring-back part of the signal.

¹¹ All Long Term Accuracy and Clock Period specifications are guaranteed assuming that REFOUT is at 14.31818MHz

AC Electrical Characteristics - Low-Power DIF Outputs: SRC and ATIG

PARAMETER	SYMBOL	CONDITIONS	MIN	TYP	MAX	UNITS	NOTES
Rising Edge Slew Rate	t_{SLR}	Differential Measurement	0.5		2	V/ns	1,2
Falling Edge Slew Rate	t_{FLR}	Differential Measurement	0.5		2	V/ns	1,2
Slew Rate Variation	t_{SLVAR}	Single-ended Measurement			20	%	1
Maximum Output Voltage	V_{HIGH}	Includes overshoot			1150	mV	1
Minimum Output Voltage	V_{LOW}	Includes undershoot	-300			mV	1
Differential Voltage Swing	V_{SWING}	Differential Measurement	300			mV	1
Crossing Point Voltage	V_{XABS}	Single-ended Measurement	300		550	mV	1,3,4
Crossing Point Variation	$V_{XABSVAR}$	Single-ended Measurement			140	mV	1,3,5
Duty Cycle	D_{CYC}	Differential Measurement	45		55	%	1
SRC, ATIG, Jitter - Cycle to Cycle	$SRCJ_{C2C}$	Differential Measurement			125	ps	1
SRC[5:0] Skew	SRC_{SKEW}	Differential Measurement			250	ps	1
SB_SRC[1:0] Skew	SRC_{SKEW}	Differential Measurement			100	ps	1
ATIG[3:0] Skew	SRC_{SKEW}	Differential Measurement			100	ps	1

¹Guaranteed by design and characterization, not 100% tested in production.

²Slew rate measured through Vswing centered around differential zero

³Vxabs is defined as the voltage where CLK = CLK#

⁴Only applies to the differential rising edge (CLK rising and CLK# falling)

⁵Defined as the total variation of all crossing voltages of CLK rising and CLK# falling. Matching applies to rising edge rate of

⁶All Long Term Accuracy and Clock Period specifications are guaranteed assuming that REFOUT is at 14.31818MHz

Electrical Characteristics - USB - 48MHz

PARAMETER	SYMBOL	CONDITIONS*	MIN	TYP	MAX	UNITS	NOTES
Long Accuracy	ppm	see Tperiod min-max values	-100		100	ppm	1,2
Clock period	T_{period}	48.00MHz output nominal	20.8229		20.8344	ns	2
Clock Low Time	T_{low}	Measure from < 0.6V	9.3750		11.4580	ns	2
Clock High Time	T_{high}	Measure from > 2.0V	9.3750		11.4580	ns	2
Output High Voltage	V_{OH}	$I_{OH} = -1$ mA	2.4			V	1
Output Low Voltage	V_{OL}	$I_{OL} = 1$ mA			0.55	V	1
Output High Current	I_{OH}	$V_{OH} @ MIN = 1.0$ V	-33			mA	1
		$V_{OH} @ MAX = 3.135$ V			-33	mA	1
Output Low Current	I_{OL}	$V_{OL} @ MIN = 1.95$ V	30			mA	1
		$V_{OL} @ MAX = 0.4$ V			38	mA	1
Rise Time	t_{r_USB}	$V_{OL} = 0.4$ V, $V_{OH} = 2.4$ V	0.5		1.5	ns	1
Fall Time	t_{f_USB}	$V_{OH} = 2.4$ V, $V_{OL} = 0.4$ V	0.5		1.5	ns	1
Duty Cycle	d_{t1}	$V_T = 1.5$ V	45		55	%	1
Group Skew	t_{skew}	$V_T = 1.5$ V			250	ps	1
Jitter, Cycle to cycle	$t_{jyc-cyc}$	$V_T = 1.5$ V			130	ps	1,2

*TA = 0 - 70°C; Supply Voltage VDD = 3.3 V +/-5%, CL = 5 pF with Rs = 33Ω (unless otherwise specified)

¹Guaranteed by design and characterization, not 100% tested in production.

²ICS recommended and/or chipset vendor layout guidelines must be followed to meet this specification

Electrical Characteristics - REF-14.318MHz

PARAMETER	SYMBOL	CONDITIONS	MIN	TYP	MAX	UNITS	Notes
Long Accuracy	ppm	see Tperiod min-max values	-100	0	100	ppm	1,2
Clock period	T_{period}	14.318MHz output nominal	69.8270	69.84	69.8550	ns	2
Clock Low Time	T_{low}	Measure from < 0.6V	30.9290		37.9130	ns	2
Clock High Time	T_{high}	Measure from > 2.0V	30.9290		37.9130	ns	2
Output High Voltage	V_{OH}	$I_{OH} = -1 \text{ mA}$	2.4			V	1
Output Low Voltage	V_{OL}	$I_{OL} = 1 \text{ mA}$			0.4	V	1
Output High Current	I_{OH}	$V_{OH} @ \text{MIN} = 1.0 \text{ V}$, $V_{OH} @ \text{MAX} = 3.135 \text{ V}$	-29		-23	mA	1
Output Low Current	I_{OL}	$V_{OL} @ \text{MIN} = 1.95 \text{ V}$, $V_{OL} @ \text{MAX} = 0.4 \text{ V}$	29		27	mA	1
Rise Time	t_{r1}	$V_{OL} = 0.4 \text{ V}$, $V_{OH} = 2.4 \text{ V}$	1		1.5	ns	1
Fall Time	t_{f1}	$V_{OH} = 2.4 \text{ V}$, $V_{OL} = 0.4 \text{ V}$	1		1.5	ns	1
Skew	t_{sk1}	$V_T = 1.5 \text{ V}$			100	ps	1
Duty Cycle	d_{t1}	$V_T = 1.5 \text{ V}$	45		55	%	1
Jitter	$t_{jyc-cyc}$	$V_T = 1.5 \text{ V}$			300	ps	1

*TA = 0 - 70°C; Supply Voltage VDD = 3.3 V +/-5%, CL = 5 pF with Rs = 33Ω (unless otherwise specified)

¹Guaranteed by design and characterization, not 100% tested in production.

²All Long Term Accuracy and Clock Period specifications are guaranteed assuming that REFOUT is at 14.31818MHz

Table1: CPU and HTT Frequency Selection Table

Byte 0					CPUCLK (2:0) (MHz)	HTT (MHz)	Spread %	Overclock %
Bit4	Bit3	Bit2	Bit1	Bit0				
CPU SS_EN	CPU FS3	CPU FS2	CPU FS1	CPU FS0				
0	0	0	0	0	Hi-Z	Hi-Z	None	
0	0	0	0	1	X / 2	X / 3	None	
0	0	0	1	0	230.00	76.67	None	15%
0	0	0	1	1	240.00	80.00	None	20%
0	0	1	0	0	100.00	66.67	None	0%
0	0	1	0	1	133.33	66.67	None	
0	0	1	1	0	166.67	66.67	None	
0	0	1	1	1	200.00	66.67	None	
0	1	0	0	0	250.00	83.33	None	25%
0	1	0	0	1	260.00	86.67	None	30%
0	1	0	1	0	270.00	90.00	None	35%
0	1	0	1	1	280.00	93.33	None	40%
0	1	1	0	0	102.00	68.00	None	2%
0	1	1	0	1	136.00	68.00	None	
0	1	1	1	0	170.00	68.00	None	
0	1	1	1	1	204.00	68.00	None	
1	0	0	0	0	210.00	70.00	-0.5%	5%
1	0	0	0	1	220.00	73.33	-0.5%	10%
1	0	0	1	0	230.00	76.67	-0.5%	15%
1	0	0	1	1	240.00	80.00	-0.5%	20%
1	0	1	0	0	100.00	66.67	-0.5%	0%
1	0	1	0	1	133.33	66.67	-0.5%	
1	0	1	1	0	166.67	66.67	-0.5%	
1	0	1	1	1	200.00	66.67	-0.5%	
1	1	0	0	0	250.00	83.33	-0.5%	25%
1	1	0	0	1	260.00	86.67	-0.5%	30%
1	1	0	1	0	270.00	90.00	-0.5%	35%
1	1	0	1	1	280.00	93.33	-0.5%	40%
1	1	1	0	0	102.00	68.00	-0.5%	2%
1	1	1	0	1	136.00	68.00	-0.5%	
1	1	1	1	0	170.00	68.00	-0.5%	
1	1	1	1	1	204.00	68.00	-0.5%	

Table2: SRC Frequency Selection Table

Byte 0 Bit 5	Byte 5				SRC(7:0) (MHz)	Spread %	SRC OverClock %
	Bit3	Bit2	Bit1	Bit0			
SRC SS_EN	SRC FS3	SRC FS2	SRC FS1	SRC FS0			
0	0	0	0	0	100.00	0	0%
0	0	0	0	1	101.00	0	1%
0	0	0	1	0	102.00	0	2%
0	0	0	1	1	103.00	0	3%
0	0	1	0	0	104.00	0	4%
0	0	1	0	1	105.00	0	5%
0	0	1	1	0	106.00	0	6%
0	0	1	1	1	107.00	0	7%
0	1	0	0	0	100.00	0	0%
0	1	0	0	1	101.00	0	1%
0	1	0	1	0	102.00	0	2%
0	1	0	1	1	103.00	0	3%
0	1	1	0	0	104.00	0	4%
0	1	1	0	1	105.00	0	5%
0	1	1	1	0	106.00	0	6%
0	1	1	1	1	107.00	0	7%
1	0	0	0	0	100.00	-0.25%	0%
1	0	0	0	1	101.00	-0.25%	1%
1	0	0	1	0	102.00	-0.25%	2%
1	0	0	1	1	103.00	-0.25%	3%
1	0	1	0	0	104.00	-0.25%	4%
1	0	1	0	1	105.00	-0.25%	5%
1	0	1	1	0	106.00	-0.25%	6%
1	0	1	1	1	107.00	-0.25%	7%
1	1	0	0	0	100.00	-0.5%	0%
1	1	0	0	1	101.00	-0.5%	1%
1	1	0	1	0	102.00	-0.5%	2%
1	1	0	1	1	103.00	-0.5%	3%
1	1	1	0	0	104.00	-0.5%	4%
1	1	1	0	1	105.00	-0.5%	5%
1	1	1	1	0	106.00	-0.5%	6%
1	1	1	1	1	107.00	-0.5%	7%

Table3: ATIG Frequency Selection Table

Byte 0	Byte 9				ATIG(2:0) (MHz)	Spread %	ATIG OverClock %
Bit 6	Bit4	Bit3	Bit1	Bit0			
ATIG SS_EN	ATIG FS3	ATIG FS2	ATIG FS1	ATIG FS0			
0	0	0	0	0	100.00	0	0%
0	0	0	0	1	105.00	0	5%
0	0	0	1	0	110.00	0	10%
0	0	0	1	1	115.00	0	15%
0	0	1	0	0	120.00	0	20%
0	0	1	0	1	125.00	0	25%
0	0	1	1	0	130.00	0	30%
0	0	1	1	1	135.00	0	35%
0	1	0	0	0	100.00	0	0%
0	1	0	0	1	105.00	0	5%
0	1	0	1	0	110.00	0	10%
0	1	0	1	1	115.00	0	15%
0	1	1	0	0	120.00	0	20%
0	1	1	0	1	125.00	0	25%
0	1	1	1	0	130.00	0	30%
0	1	1	1	1	135.00	0	35%
1	0	0	0	0	100.00	-0.25%	0%
1	0	0	0	1	105.00	-0.25%	5%
1	0	0	1	0	110.00	-0.25%	10%
1	0	0	1	1	115.00	-0.25%	15%
1	0	1	0	0	120.00	-0.25%	20%
1	0	1	0	1	125.00	-0.25%	25%
1	0	1	1	0	130.00	-0.25%	30%
1	0	1	1	1	135.00	-0.25%	35%
1	1	0	0	0	100.00	-0.5%	0%
1	1	0	0	1	105.00	-0.5%	5%
1	1	0	1	0	110.00	-0.5%	10%
1	1	0	1	1	115.00	-0.5%	15%
1	1	1	0	0	120.00	-0.5%	20%
1	1	1	0	1	125.00	-0.5%	25%
1	1	1	1	0	130.00	-0.5%	30%
1	1	1	1	1	135.00	-0.5%	35%

Table 4: CPU Divider Ratios

B19b(7:4)		Divider (3:2)							
Divider (1:0)	Bit	00		01		10		11	MSB
	00	0000	2	0100	4	1000	8	1100	16
	01	0001	3	0101	6	1001	12	1101	24
	10	0010	5	0110	10	1010	20	1110	40
	11	0011	15	0111	30	1011	60	1111	120
LSB	Address	Div	Address		Address	Div	Address	Div	

Table 5: HTT Divider Ratios

B20b(3:0)		Divider (3:2)							
Divider (1:0)	Bit	00		01		10		11	MSB
	00	0000	4	0100	8	1000	16	1100	32
	01	0001	3	0101	6	1001	12	1101	24
	10	0010	5	0110	10	1010	20	1110	40
	11	0011	15	0111	30	1011	60	1111	120
LSB	Address	Div	Address		Address	Div	Address	Div	

Table 6: ATIG Divider Ratios

B19b(3:0)		Divider (3:2)							
Divider (1:0)	Bit	00		01		10		11	MSB
	00	0000	2	0100	4	1000	8	1100	16
	01	0001	3	0101	6	1001	12	1101	24
	10	0010	5	0110	10	1010	20	1110	40
	11	0011	7	0111	14	1011	28	1111	56
LSB	Address	Div	Address		Address	Div	Address	Div	

CPU Clock			
Common Recommendations for Differential Routing	Dimension or Value	Unit	Figure
L1 length, Route as coupled 93 ohm trace.	0.5 max	inch	1
L2 length, Route as coupled 93 ohm trace.	Contact AMD	inch	1

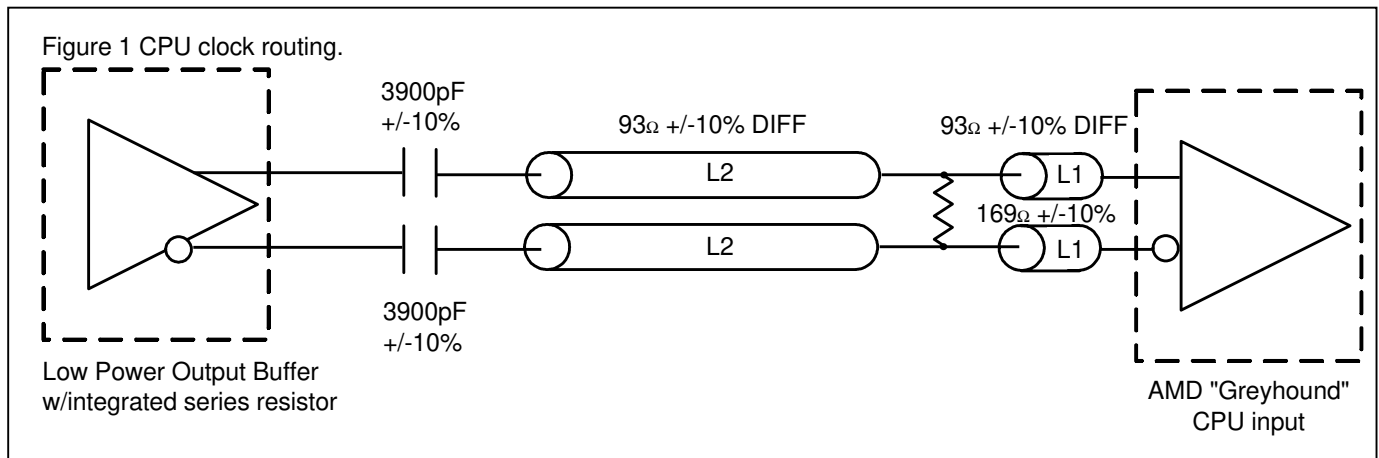

SRC Reference Clock			
Common Recommendations for Differential Routing	Dimension or Value	Unit	Figure
L1 length, Route as non-coupled 50 ohm trace.	0.5 max	inch	2
L2 length, Route as non-coupled 50 ohm trace.	N/A	inch	2
L3 length, Route as non-coupled 50 ohm trace.	N/A	inch	2
Rs	33	ohm	2
Rt	49.9	ohm	2

Down Device Differential Routing	Dimension or Value	Unit	Figure
L4 length, Route as coupled microstrip 100 ohm differential trace.	2 min to 16 max	inch	2
L4 length, Route as coupled stripline 100 ohm differential trace.	1.8 min to 14.4 max	inch	2

Differential Routing to PCI Express Connector	Dimension or Value	Unit	Figure
L4 length, Route as coupled microstrip 100 ohm differential trace.	0.25 to 14 max	inch	3
L4 length, Route as coupled stripline 100 ohm differential trace.	0.225 min to 12.6 max	inch	3

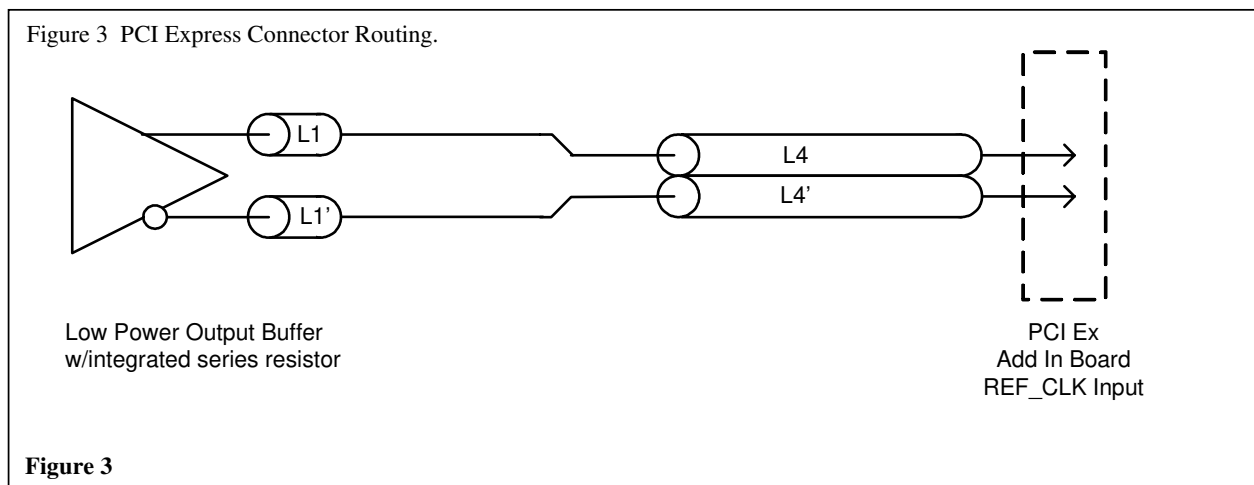
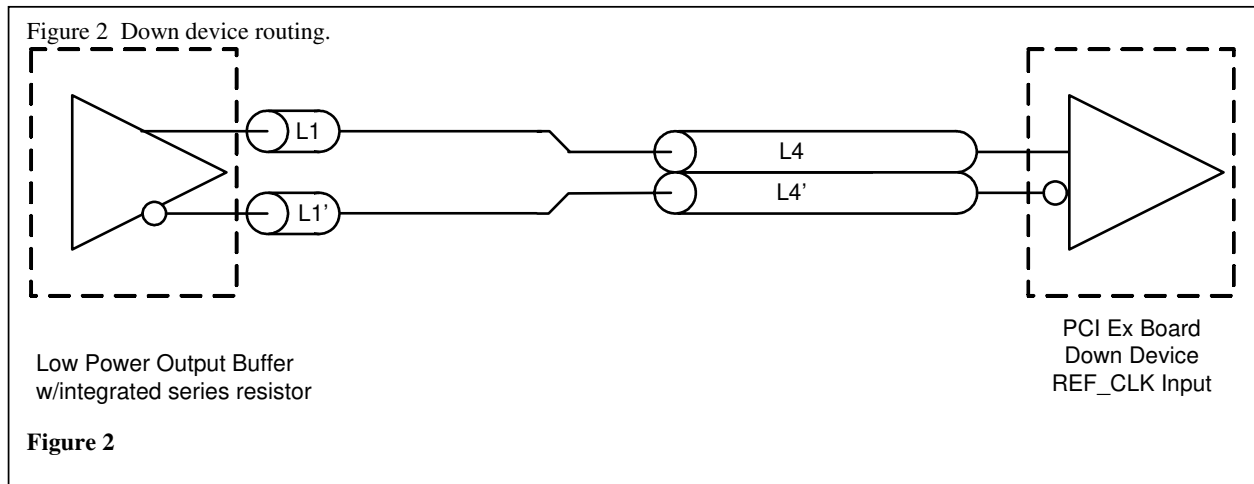

General SMBus serial interface information for the ICS9LPRS462

How to Write:

- Controller (host) sends a start bit.
- Controller (host) sends the write address $D2_{(H)}$
- ICS clock will **acknowledge**
- Controller (host) sends the beginning byte location = N
- ICS clock will **acknowledge**
- Controller (host) sends the data byte count = X
- ICS clock will **acknowledge**
- Controller (host) starts sending **Byte N through Byte N + X - 1**
- ICS clock will **acknowledge** each byte **one at a time**
- Controller (host) sends a Stop bit

How to Read:

- Controller (host) will send start bit.
- Controller (host) sends the write address $D2_{(H)}$
- ICS clock will **acknowledge**
- Controller (host) sends the beginning byte location = N
- ICS clock will **acknowledge**
- Controller (host) will send a separate start bit.
- Controller (host) sends the read address $D3_{(H)}$
- ICS clock will **acknowledge**
- ICS clock will send the data byte count = X
- ICS clock sends **Byte N + X - 1**
- ICS clock sends **Byte 0 through byte X (if $X_{(H)}$ was written to byte 8).**
- Controller (host) will need to acknowledge each byte
- Controller (host) will send a not acknowledge bit
- Controller (host) will send a stop bit

Index Block Write Operation		
Controller (Host)		ICS (Slave/Receiver)
T	starT bit	
Slave Address $D2_{(H)}$		
WR	WRite	
		ACK
Beginning Byte = N		
		ACK
Data Byte Count = X		
		ACK
Beginning Byte N		X Byte
○		
○		
○		
○		
Byte N + X - 1		
		ACK
P	stoP bit	

Index Block Read Operation		
Controller (Host)		ICS (Slave/Receiver)
T	starT bit	
Slave Address $D2_{(H)}$		
WR	WRite	
		ACK
Beginning Byte = N		
		ACK
RT	Repeat starT	
Slave Address $D3_{(H)}$		
RD	ReaD	
		ACK
		Data Byte Count = X
ACK		
ACK		X Byte
○		
○		
○		
		Byte N + X - 1
N	Not acknowledge	
P	stoP bit	

SMBus Table: Spread Spectrum Enable and CPU Frequency Select Register

Byte 0	Pin #	Name	Control Function	Type	0	1	PWD
Bit 7	-	FS Source	Latched Input or SMBus Frequency Select	RW	Latched Inputs	SMBus	0
Bit 6	-	ATIG SS_EN	ATIG Spread Spectrum Enable	RW	Disable	Enable	0
Bit 5	-	SRC SS_EN	SRC Spread Spectrum Enable	RW	Disable	Enable	0
Bit 4	-	CPU SS_EN	CPU Spread Spectrum Enable	RW	Disable	Enable	0
Bit 3	-	CPU FS3	CPU Freq Select Bit 3	RW	See Table 1: CPU Frequency Selection Table		0
Bit 2	-	CPU FS2	CPU Freq Select Bit 2	RW			Latch
Bit 1	-	CPU FS1	CPU Freq Select Bit 1	RW			Latch
Bit 0	-	CPU FS0	CPU Freq Select Bit 0	RW			Latch

Note: Each Spread Spectrum Enable bit is independent from the other.
Bit(6:4) must all set to "1" in order to enable spread for CPU, SRC and ATIG clocks.

SMBus Table: Output Control Register

Byte 1	Pin #	Name	Control Function	Type	0	1	PWD
Bit 7	7	48MHz_1	48MHz_1 Output Enable	RW	Disable	Enable	1
Bit 6	6	48MHz_0	48MHz_0 Output Enable	RW	Disable	Enable	1
Bit 5	54	REF2	REF2 Output Enable	RW	Disable	Enable	1
Bit 4	55	REF1	REF1 Output Enable	RW	Disable	Enable	1
Bit 3	56	REF0	REF0 Output Enable	RW	Disable	Enable	1
Bit 2	51	HTTCLK0	HTTCLK0 Output Enable	RW	Disable	Enable	1
Bit 1	44,43	CPUCLK1	CPUCLK1 Output Enable	RW	Disable	Enable	1
Bit 0	48,47	CPUCLK0	CPUCLK0 Output Enable	RW	Disable	Enable	1

SMBus Table: ATIGCLK and CLKREQB# Output Control Register

Byte 2	Pin #	Name	Control Function	Type	0	1	PWD
Bit 7	Reserved						0
Bit 6	Reserved						0
Bit 5	31,30	ATIGCLK1	ATIGCLK1 Output Enable	RW	Disable	Enable	1
Bit 4	35,34	ATIGCLK0	ATIGCLK0 Output Enable	RW	Disable	Enable	1
Bit 3	20,21	REQBSRC2	CLKREQB# Controls SRC2	RW	Does not control	Controls	0
Bit 2	Reserved						0
Bit 1	24,25	REQBSRC1	CLKREQB# Controls SRC1	RW	Does not control	Controls	0
Bit 0	Reserved						0

SMBus Table: SRCCLK Output Control Register

Byte 3	Pin #	Name	Control Function	Type	0	1	PWD
Bit 7	12,13	SRCCLK5	Master Output control. Enables or disables output, regardless of CLKREQ# inputs.	RW	Disable	Enable	1
Bit 6	16,17	SRCCLK4		RW	Disable	Enable	1
Bit 5	18,19	SRCCLK3		RW	Disable	Enable	1
Bit 4	20,21	SRCCLK2		RW	Disable	Enable	1
Bit 3		Reserved		-	-	-	1
Bit 2	24,25	SRCCLK1		RW	Disable	Enable	1
Bit 1		Reserved		-	-	-	1
Bit 0	39,38	SRCCLK0		RW	Disable	Enable	1

SMBus Table: CLKREQB# and CLKREQC# Output Control Register

Byte 4	Pin #	Name	Control Function	Type	0	1	PWD
Bit 7	12,13	REQASRC5	CLKREQA# Controls SRC5	RW	Does not control	Controls	0
Bit 6	16,17	REQASRC4	CLKREQA# Controls SRC4	RW	Does not control	Controls	0
Bit 5	18,19	REQASRC3	CLKREQA# Controls SRC3	RW	Does not control	Controls	0
Bit 4	Reserved						0
Bit 3	Reserved						0
Bit 2	31,30	REQCATIG1	CLKREQC# Controls ATIG1	RW	Does not control	Controls	0
Bit 1	35,34	REQCATIG0	CLKREQC# Controls ATIG0	RW	Does not control	Controls	0
Bit 0	39,38	REQSRC0	CLKREQC# Controls SRC0	RW	Does not control	Controls	0

SMBus Table: CPU Stop Control and SRC Frequency Select Register

Byte 5	Pin #	Name	Control Function	Type	0	1	PWD
Bit 7		IO_VOUT2	IO Output Voltage Select (Most Significant Bit)	RW	See Table 8: V_IO Selection (Default is 0.8V)		1
Bit 6		IO_VOUT1	IO Output Voltage Select	RW			0
Bit 5		IO_VOUT0	IO Output Voltage Select (Least Significant Bit)	RW			1
Bit 4	Reserved						0
Bit 3	-	SRC FS3	SRC Freq Select Bit 3	RW	See Table 2: SRC Frequency Selection Table		0
Bit 2	-	SRC FS2	SRC Freq Select Bit 2	RW			0
Bit 1	-	SRC FS1	SRC Freq Select Bit 1	RW			0
Bit 0	-	SRC FS0	SRC Freq Select Bit 0	RW			0

SMBus Table: Device ID Register

Byte 6	Pin #	Name	Control Function	Type	0	1	PWD
Bit 7	-	Device ID7 (MSB)	DEVICE ID	R	-	-	0
Bit 6	-	Device ID6		R	-	-	1
Bit 5	-	Device ID5		R	-	-	1
Bit 4	-	Device ID4		R	-	-	0
Bit 3	-	Device ID3		R	-	-	0
Bit 2	-	Device ID2		R	-	-	1
Bit 1	-	Device ID1		R	-	-	0
Bit 0	-	Device ID0 (LSB)		R	-	-	0

SMBus Table: Revision and Vendor ID Register

Byte 7	Pin #	Name	Control Function	Type	0	1	PWD
Bit 7	-	RID3	REVISION ID	R	-	-	0
Bit 6	-	RID2		R	-	-	0
Bit 5	-	RID1		R	-	-	0
Bit 4	-	RID0		R	-	-	0
Bit 3	-	VID3	VENDOR ID	R	-	-	0
Bit 2	-	VID2		R	-	-	0
Bit 1	-	VID1		R	-	-	0
Bit 0	-	VID0		R	-	-	1

SMBus Table: Byte Count Register

Byte 8	Pin #	Name	Control Function	Type	0	1	PWD
Bit 7	-	BC7	Byte Count Programming b(7:0)	RW	Writing to this register will configure how many bytes will be read back, default is 9 bytes.		0
Bit 6	-	BC6		RW			0
Bit 5	-	BC5		RW			0
Bit 4	-	BC4		RW			0
Bit 3	-	BC3		RW			1
Bit 2	-	BC2		RW			0
Bit 1	-	BC1		RW			0
Bit 0	-	BC0		RW			1

SMBus Table: REF2, 48MHz Output Strength Control and ATIG Frequency Select Register

Byte 9	Pin #	Name	Control Function	Type	0	1	PWD
Bit 7	54	REF2Str	REF2 Strength Control	RW	1X	2X	1
Bit 6	7	48MHz_1Str	48MHz_1 Strength Control	RW	1X	2X	1
Bit 5	6	48MHz_0Str	48MHz_0 Strength Control	RW	1X	2X	1
Bit 4	-	Reserved					0
Bit 3	-	ATIG FS3	ATIG Freq Select Bit 3	RW	See Table 3: ATIG Frequency Selection Table		0
Bit 2	-	ATIG FS2	ATIG Freq Select Bit 2	RW			0
Bit 1	-	ATIG FS1	ATIG Freq Select Bit 1	RW			0
Bit 0	-	ATIG FS0	ATIG Freq Select Bit 0	RW			0

SMBus Table: PLLs M/N Programming Enable and REF1, REF0 Output Strength Control Register

Byte 10	Pin #	Name	Control Function	Type	0	1	PWD
Bit 7	-	M/N_EN	PLLs M/N Programming Enable	RW	Disable	Enable	0
Bit 6	55	REF1Str	REF1 Strength Control	RW	1X	2X	1
Bit 5	56	REF0Str	REF0 Strength Control	RW	1X	2X	1
Bit 4	-	Reserved					0
Bit 3	-	Reserved					0
Bit 2	-	Reserved					0
Bit 1	-	Reserved					0
Bit 0	-	Reserved					0

SMBus Table: CPU PLL VCO Frequency Control Register

Byte 11	Pin #	Name	Control Function	Type	0	1	PWD
Bit 7	-	N Div8	N Divider Prog bit 8	RW	The decimal representation of M and N Divider in Byte 11 and 12 will configure the VCO frequency. Default at power up = latch-in or Byte 0 Rom table. VCO Frequency = $14.318 \times [\text{NDiv}(9:0)+8] / [\text{MDiv}(5:0)+2]$		X
Bit 6	-	N Div 9	N Divider Prog bit 9	RW			X
Bit 5	-	M Div5	M Divider Programming bits	RW			X
Bit 4	-	M Div4		RW			X
Bit 3	-	M Div3		RW			X
Bit 2	-	M Div2		RW			X
Bit 1	-	M Div1		RW			X
Bit 0	-	M Div0		RW			X

SMBus Table: CPU PLL VCO Frequency Control Register

Byte 12	Pin #	Name	Control Function	Type	0	1	PWD
Bit 7	-	N Div7	N Divider Programming b(7:0)	RW	The decimal representation of M and N Divider in Byte 11 and 12 will configure the VCO frequency. Default at power up = latch-in or Byte 0 Rom table. VCO Frequency = $14.318 \times [\text{NDiv}(9:0)+8] / [\text{MDiv}(5:0)+2]$		X
Bit 6	-	N Div6		RW			X
Bit 5	-	N Div5		RW			X
Bit 4	-	N Div4		RW			X
Bit 3	-	N Div3		RW			X
Bit 2	-	N Div2		RW			X
Bit 1	-	N Div1		RW			X
Bit 0	-	N Div0		RW			X

SMBus Table: CPU PLL Spread Spectrum Control Register

Byte 13	Pin #	Name	Control Function	Type	0	1	PWD
Bit 7	-	SSP7	Spread Spectrum Programming b(7:0)	RW	These Spread Spectrum bits in Byte 13 and 14 will program the spread percentage. It is recommended to use ICS Spread % table for spread programming.		X
Bit 6	-	SSP6		RW			X
Bit 5	-	SSP5		RW			X
Bit 4	-	SSP4		RW			X
Bit 3	-	SSP3		RW			X
Bit 2	-	SSP2		RW			X
Bit 1	-	SSP1		RW			X
Bit 0	-	SSP0		RW			X

SMBus Table: CPU PLL Spread Spectrum Control Register

Byte 14	Pin #	Name	Control Function	Type	0	1	PWD
Bit 7	-		Reserved				0
Bit 6	-	SSP14	Spread Spectrum Programming b(14:8)	RW	These Spread Spectrum bits in Byte 13 and 14 will program the spread percentage. It is recommended to use ICS Spread % table for spread programming.		X
Bit 5	-	SSP13		RW			X
Bit 4	-	SSP12		RW			X
Bit 3	-	SSP11		RW			X
Bit 2	-	SSP10		RW			X
Bit 1	-	SSP9		RW			X
Bit 0	-	SSP8		RW			X

SMBus Table: ATIG PLL VCO Frequency Control Register

Byte 15	Pin #	Name	Control Function	Type	0	1	PWD
Bit 7	-	N Div8	N Divider Prog bit 8	RW	The decimal representation of M and N Divier in Byte 17 and 18 will configure the VCO frequency. Default at power up = Byte 0 Rom table. VCO Frequency = 14.318 x [NDiv(9:0)+8] / [MDiv(5:0)+2]		X
Bit 6	-	N Div9	N Divider Prog bit 9	RW			X
Bit 5	-	M Div5	M Divider Programming bits	RW			X
Bit 4	-	M Div4		RW			X
Bit 3	-	M Div3		RW			X
Bit 2	-	M Div2		RW			X
Bit 1	-	M Div1		RW			X
Bit 0	-	M Div0		RW			X

SMBus Table: ATIG PLL VCO Frequency Control Register

Byte 16	Pin #	Name	Control Function	Type	0	1	PWD
Bit 7	-	N Div7	N Divider Programming b(7:0)	RW	The decimal representation of M and N Divier in Byte 17 and 18 will configure the VCO frequency. Default at power up = Byte 0 Rom table. VCO Frequency = 14.318 x [NDiv(9:0)+8] / [MDiv(5:0)+2]		X
Bit 6	-	N Div6		RW			X
Bit 5	-	N Div5		RW			X
Bit 4	-	N Div4		RW			X
Bit 3	-	N Div3		RW			X
Bit 2	-	N Div2		RW			X
Bit 1	-	N Div1		RW			X
Bit 0	-	N Div0		RW			X

SMBus Table: ATIG PLL Spread Spectrum Control Register

Byte 17	Pin #	Name	Control Function	Type	0	1	PWD
Bit 7	-	SSP7	Spread Spectrum Programming b(7:0)	RW	These Spread Spectrum bits in Byte 19 and 20 will program the spread percentage. It is recommended to use ICS Spread % table for spread programming.		X
Bit 6	-	SSP6		RW			X
Bit 5	-	SSP5		RW			X
Bit 4	-	SSP4		RW			X
Bit 3	-	SSP3		RW			X
Bit 2	-	SSP2		RW			X
Bit 1	-	SSP1		RW			X
Bit 0	-	SSP0		RW			X

SMBus Table: ATIG PLL Spread Spectrum Control Register

Byte 18	Pin #	Name	Control Function	Type	0	1	PWD
Bit 7			Reserved				0
Bit 6	-	SSP14	Spread Spectrum Programming b(14:8)	RW	These Spread Spectrum bits in Byte 19 and 20 will program the spread percentage. It is recommended to use ICS Spread % table for spread programming.		X
Bit 5	-	SSP13		RW		X	
Bit 4	-	SSP12		RW		X	
Bit 3	-	SSP11		RW		X	
Bit 2	-	SSP10		RW		X	
Bit 1	-	SSP9		RW		X	
Bit 0	-	SSP8		RW		X	

SMBus Table: CPU and ATIG Divider Ratio Programming Bits Select Register

Byte 19	Pin #	Name	Control Function	Type	0	1	PWD
Bit 7	-	CPU_Div3	CPU_Divider Ratio Programming Bits	RW	See Table 4: CPU Divider Ratios		X
Bit 6	-	CPU_Div2		RW		X	
Bit 5	-	CPU_Div1		RW		X	
Bit 4	-	CPU_Div0		RW		X	
Bit 3	-	ATIG_Div3	ATIG_Divider Ratio Programming Bits	RW	See Table 5: ATIG Divider Ratios		X
Bit 2	-	ATIG_Div2		RW		X	
Bit 1	-	ATIG_Div1		RW		X	
Bit 0	-	ATIG_Div0		RW		X	

SMBus Table: HTT Divider Ratio Programming Bits Select Register

Byte 20	Pin #	Name	Control Function	Type	0	1	PWD
Bit 7			Reserved				0
Bit 6			Reserved				0
Bit 5			Reserved				0
Bit 4			Reserved				0
Bit 3	-	HTT_Div3	HTT_Divider Ratio Programming Bits	RW	See Table 6: HTT Divider Ratios		X
Bit 2	-	HTT_Div2		RW		X	
Bit 1	-	HTT_Div1		RW		X	
Bit 0	-	HTT_Div0		RW		X	

RESET_IN# - Assertion (transition from '1' to '0')

Asserting RESET_IN pin stops all the outputs including CPU, SRC, ATIG, PCI and USB with the REF[2:0] running. The pin is a Schmitt trigger input with debouncing. After it is triggered, REF clocks will wait for two clock cycle to ensure the RESET_IN is asserted. Then, it will take 3 μ S for the clocks to stop without glitches. The clock chip will be power down and re-power up, and SMBus will be reloaded. It will take no more than 2.5mS for the clocks to come out with correct frequencies and no glitches.

** Deassertion of RESET_IN# (transition from '0' to '1') has NO effect on the clocks.

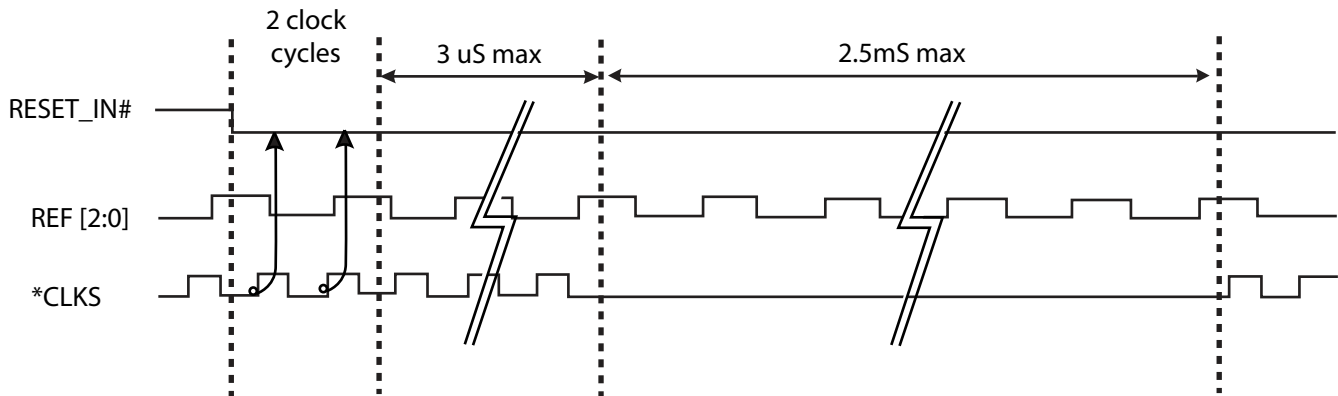

Shared Pin Operation - Input/Output Pins

The I/O pins designated by (input/output) on the **ICS9LPRS462** serve as dual signal functions to the device. During initial power-up, they act as input pins. The logic level (voltage) that is present on these pins at this time is read and stored into a 5-bit internal data latch. At the end of Power-On reset, (see AC characteristics for timing values), the device changes the mode of operations for these pins to an output function. In this mode the pins produce the specified buffered clocks to external loads.

To program (load) the internal configuration register for these pins, a resistor is connected to either the VDD (logic 1) power supply or the GND (logic 0) voltage potential. A 10 Kilohm (10K) resistor is used to provide both the solid CMOS programming voltage needed during the power-up programming period and to provide an insignificant load on the output clock during the subsequent operating period.

Figure 1 shows a means of implementing this function when a switch or 2 pin header is used. With no jumper is installed the pin will be pulled high. With the jumper in place the pin will be pulled

low. If programmability is not necessary, than only a single resistor is necessary. The programming resistors should be located close to the series termination resistor to minimize the current loop area. It is more important to locate the series termination resistor close to the driver than the programming resistor.

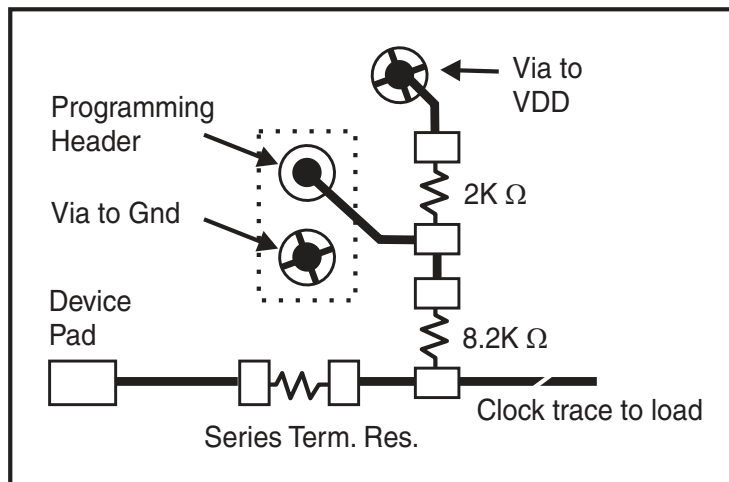
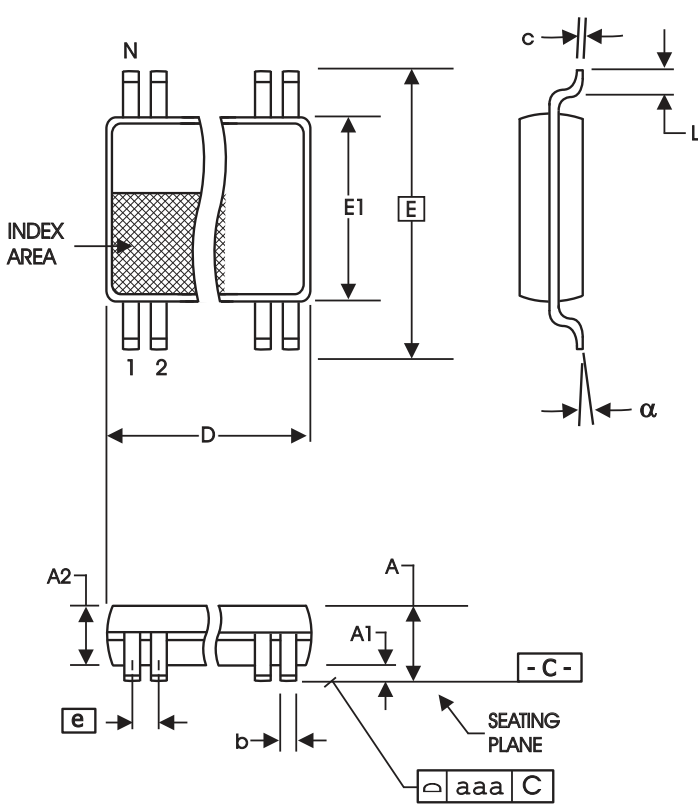

Fig. 1



6.10 mm. Body, 0.50 mm. Pitch TSSOP
(240 mil) (20 mil)

SYMBOL	In Millimeters		In Inches	
	COMMON DIMENSIONS		COMMON DIMENSIONS	
	MIN	MAX	MIN	MAX
A	--	1.20	--	.047
A1	0.05	0.15	.002	.006
A2	0.80	1.05	.032	.041
b	0.17	0.27	.007	.011
c	0.09	0.20	.0035	.008
D	SEE VARIATIONS		SEE VARIATIONS	
E	8.10 BASIC		0.319 BASIC	
E1	6.00	6.20	.236	.244
e	0.50 BASIC		0.020 BASIC	
L	0.45	0.75	.018	.030
N	SEE VARIATIONS		SEE VARIATIONS	
alpha	0°	8°	0°	8°
aaa	--	0.10	--	.004

VARIATIONS

N	D mm.		D (inch)	
	MIN	MAX	MIN	MAX
64	16.90	17.10	.665	.673

Reference Doc.: JEDEC Publication 95, MO-153

10-0039

Ordering Information

ICS 9LPRS462yGLFT

Example:

ICS XXXX y G LFT

- Designation for tape and reel packaging
- Lead Free, RoHS Compliant
- Package Type
G = TSSOP
- Revision Designator (will not correlate with datasheet revision)
- Device Type

Revision History

Rev.	Issue Date	Description	Page #
A	4/7/2008	1. Updated IDD current. 2. Added Down device routing Diagram and PCI Express Connector Routing Diagram. 3. Going to Release. 4. Updated Rs on REF & USB to 33ohm. 5. Corrected REF ppm to +/- 100ppm.	5,7-8,13

This product is protected by United States Patent NO. 7,342,420 and other patents.

IMPORTANT NOTICE AND DISCLAIMER

RENESAS ELECTRONICS CORPORATION AND ITS SUBSIDIARIES (“RENESAS”) PROVIDES TECHNICAL SPECIFICATIONS AND RELIABILITY DATA (INCLUDING DATASHEETS), DESIGN RESOURCES (INCLUDING REFERENCE DESIGNS), APPLICATION OR OTHER DESIGN ADVICE, WEB TOOLS, SAFETY INFORMATION, AND OTHER RESOURCES “AS IS” AND WITH ALL FAULTS, AND DISCLAIMS ALL WARRANTIES, EXPRESS OR IMPLIED, INCLUDING, WITHOUT LIMITATION, ANY IMPLIED WARRANTIES OF MERCHANTABILITY, FITNESS FOR A PARTICULAR PURPOSE, OR NON-INFRINGEMENT OF THIRD PARTY INTELLECTUAL PROPERTY RIGHTS.

These resources are intended for developers skilled in the art designing with Renesas products. You are solely responsible for (1) selecting the appropriate products for your application, (2) designing, validating, and testing your application, and (3) ensuring your application meets applicable standards, and any other safety, security, or other requirements. These resources are subject to change without notice. Renesas grants you permission to use these resources only for development of an application that uses Renesas products. Other reproduction or use of these resources is strictly prohibited. No license is granted to any other Renesas intellectual property or to any third party intellectual property. Renesas disclaims responsibility for, and you will fully indemnify Renesas and its representatives against, any claims, damages, costs, losses, or liabilities arising out of your use of these resources. Renesas' products are provided only subject to Renesas' Terms and Conditions of Sale or other applicable terms agreed to in writing. No use of any Renesas resources expands or otherwise alters any applicable warranties or warranty disclaimers for these products.

(Disclaimer Rev.1.0 Mar 2020)

Corporate Headquarters

TOYOSU FORESIA, 3-2-24 Toyosu,
Koto-ku, Tokyo 135-0061, Japan
www.renesas.com

Contact Information

For further information on a product, technology, the most up-to-date version of a document, or your nearest sales office, please visit:
www.renesas.com/contact/

Trademarks

Renesas and the Renesas logo are trademarks of Renesas Electronics Corporation. All trademarks and registered trademarks are the property of their respective owners.