

REVISIONS			
REV.	DESCRIPTION	DATE	APPROVED
A	INITIAL RELEASE	01/30/14	M.J.
B	UPDATED NOTES	03/05/18	C.E.

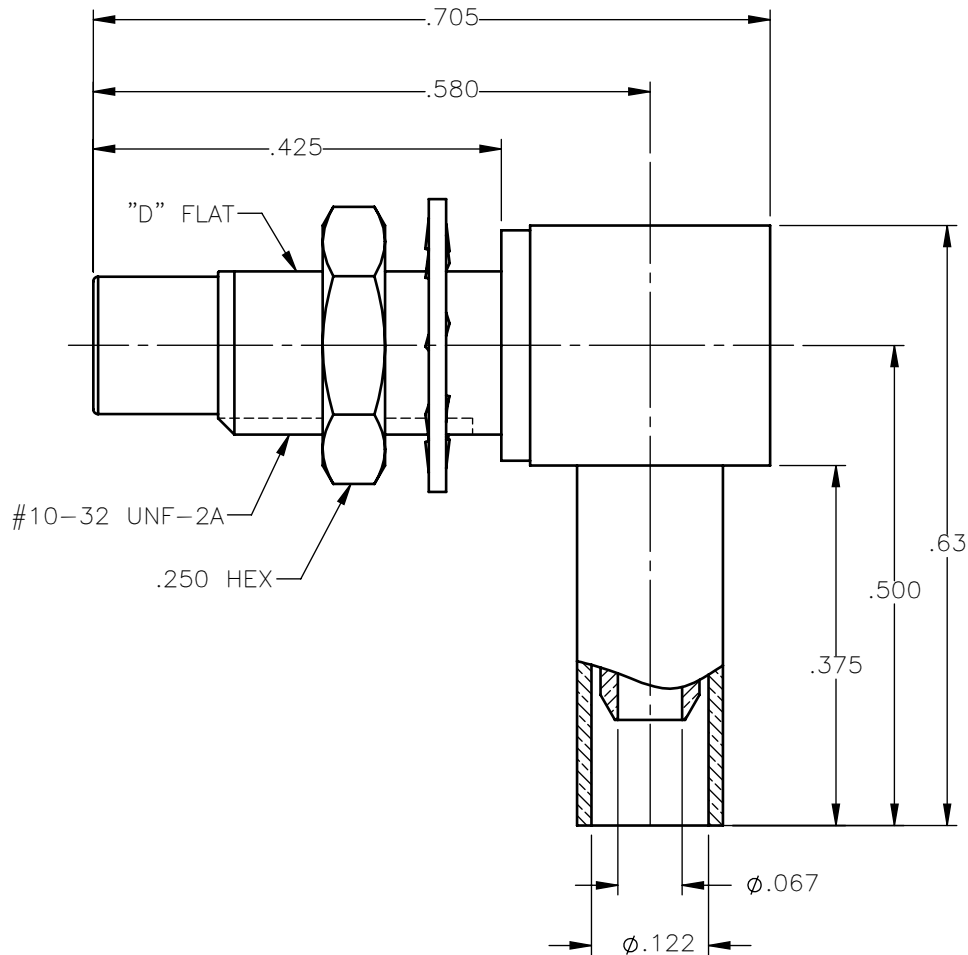



NOTES:

MATERIALS:

1. INSULATORS = VIRGIN WHITE TEFLON PER ASTM D1710, GRADE 1, TYPE I, CLASS "B".
2. LOCKWASHER = PHOSPHOR BRONZE PER ASTM B139, COPPER ALLOY C53400, TEMPER H04.
3. CRIMP SLEEVE = SEAMLESS LOWLEAD BRASS TUBE, ALLOY 330, SOFT ANNEAL TEMPER, .025/.060 GRAIN SIZE OR SEAMLESS COPPER TUBE PER ASTM B75, TYPE C12000, TEMPER: LIGHT ANNEAL O50 EXCEPT YIELD STRENGTH.
4. ALL OTHER METAL PARTS = BRASS PER ASTM B16, ALLOY C36000, TEMPER H02.

FINISHES:

1. CONTACT = GOLD PLATE PER ASTM B488-11, TYPE II, 50µin MIN, GRADE C, OVER 100 TO 200µin STRESS FREE SULFAMATE NICKEL PER AMS-QQ-N-290.
2. ALL OTHER METAL PARTS = GOLD PLATE PER ASTM B488-11, TYPE II, 30µin MIN, GRADE C OVER 100 TO 200µin COPPER STRIKE PER AMS 2418.

UNLESS OTHERWISE SPECIFIED DIMENSIONS ARE IN INCHES TOLERANCES ON	DWN: M.J.	DATE 01/30/14	 Property of Radiall This document cannot be reproduced or communicated to a third party without prior written permission of RADIALL.		
	CHKD: J.S.	DATE 01/30/14			
DECIMAL	ANGLE	APVD: J.M.	DATE 01/30/14	<b>SMC RIGHT ANGLE MALE JACK CRIMP TYPE FOR RG-316 &amp; SIMILAR CABLES</b>	
REFERENCE:	MATERIALS & FINISHES: SEE NOTES	SIZE A	FSCM NO. 19505		DWG NO. 1106-1521-003
ORIGINATED: M.J. DATE: 01/30/14	SCALE 5:1		THIRD ANGLE PROJECTION		SHEET 1 OF 1

1106-1521-003