



ITT

Electronic Components

Cannon 50 Ohm RF Connectors



Engineered for life

Over 90 year history ...

ITT Electronic Components is an innovative and dynamic company with the in-depth experience of a 90 plus year industry leader. We are part of ITT Corporation, a multi-disciplined, multi-national company engaged in the design and manufacture of electronic components, defense products and fluid handling controls.

ITT operates globally and is active in many diverse markets including telecom, carrier networks, wireless, medical electronics, instrumentation, military, microwave components, information systems and radar. ITT is an approved manufacturer to ISO 9001 and ISO 14001.



Broad range of Cannon connectors and cable assemblies

In addition to our 50 Ohm RF product line, we also offer a range of 75 Ohm connectors including Type 43 (SMZ), 1.0/2.3, 1.6/5.6 and BNC.

Cannon CoSMID™ connectors

CoSMID™ (Coax Surface Mount MID) 75 ohm connectors use molded interconnect device technology – a process which allows the selective metallization of 3D plastic shapes. Two, three or four coaxial connector lines can be integrated into a single surface mountable module. The modular design means that designers can incorporate more coax lines on a card edge than ever before.



QT - Quick Termination Connectors

Quick Termination connectors have the special QT contact pre-assembled into the main connector assembly, which eliminates the process of crimping or soldering onto the center conductor of a cable. The center conductor is terminated to the inner contact within the connector assembly, by activating the QT (patented) mechanism using the simple plastic tool provided. The assembly is completed in 4 simple steps.

1. Strip cable using standard tooling.
2. Assemble connector on to cable.
3. Press insulator into connector body.
4. Crimp the ferrule using standard hex crimp tool to complete the termination.

The QT principle may be applied to 50 Ohm products also. Contact our Customer Service group for more information.

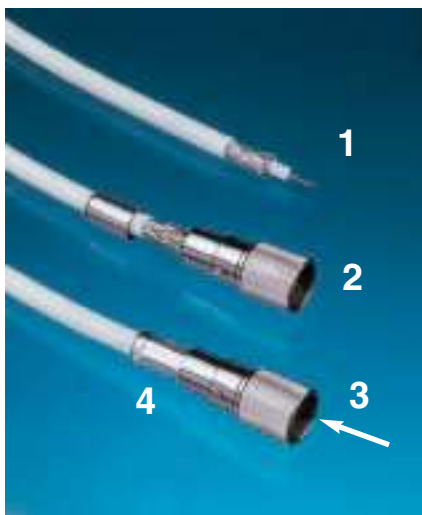

CoSMID is a trademark of ITT Corporation.
CANNON, ENGINEERED FOR LIFE, the ITT "Engineered Blocks" symbol and the composite ITT logo are registered trademarks of ITT Corporation © 2007



TABLE OF CONTENTS

Description	Page
Selection Guide	4
SMA (Precision) Connectors	6
SMA (Commercial) Connectors	13
SMB Connectors	19
SMC Connectors	24
SSMB Connectors	27
SSMC Connectors	31
Coaxial Terminators	33
Between Series Adaptors	35
Sealflex 2™ Assemblies	37
Mounting Information	40
Assembly Instructions	41
Tooling	58
Glossary of Terms	60
Part Number Index	61
Product Safety Information	62

CABLE ASSEMBLY SERVICE

Cannon has a precision cable assembly facility for the manufacture and testing of a wide range of cable / connector assemblies. By using Cannon's considerable expertise in this field, the customer is relieved of expensive training, tooling and reject problems. This invariably offers economic and logistical advantages when compared to user assembly.

Flexible, semi-rigid and Sealflex 2 RF and microwave coaxial cable assemblies for DC to 40 GHz are manufactured to the most complex customer designs and exacting mechanical and electrical tolerances. A full range of MIL-C-17G proprietary flexible and semi-rigid cables are used as well as the Sealflex 2 fully flexible, low loss microwave cable. With computerized semi-rigid cable forming and Vector Network Analyzer test equipment cable assemblies are manufactured for quality conscious customers the world over. Our skills, experience and 100% electrical testing allow us to build products that meet or exceed expectations.

75 OHM CONNECTORS

Cannon also offer a wide selection of 75 Ohm connectors for switching and transmission in telecom applications. These include the popular Type 43 (SMZ), 1.0/2.3, 1.6/5.6 and BNC connector ranges incorporating the CoSMID™ surface mountable modular technology and the (patented) 'QT' quick termination designs. The CoSMID modular design allows designers to incorporate more coax lines on a card edge than ever before and the QT assembly eliminates the process of crimping or soldering onto the centre conductor of the cable.

FAKRA CONNECTORS

In addition to the range of SMB connectors we also offer FAKRA connectors for automotive applications.

For more details on any of the products listed above, please visit www.ittcannon.com.

CONNECTOR / CABLE SELECTION GUIDE

Given here are details of all popular cables with which the connectors in this publication may be used.

Cable numbers suitable for use with all cable mounting connectors are given opposite the connector part numbers in the series chosen.

Cable Number	Impedance (ohms)	Diameter of Jacket	Diameter of Outer Conductor (Max)	Diameter of Dielectric (Max)	Diameter of Center Conductor (Nom)
BT3002	75	3,55 (.140)	2,85 (.112)	1,95 (.077)	0,31 (.012)
RD179*	75	3,07 (.121)	2,69 (.106)	1,68 (.066)	0,30 (.012)
RD316*	50	3,00 (.118)	2,79 (.101)	1,60 (.063)	0,51 (.020)
RG174/U	50	2,67 (.105)	2,24 (.088)	1,60 (.063)	0,48 (.019)
RG178/U	50	1,91 (.075)	1,37 (.054)	0,91 (.036)	0,30 (.012)
RG179/U	75	2,67 (.105)	2,13 (.084)	1,68 (.066)	0,30 (.012)
RG187/U	75	2,80 (.110)	2,13 (.084)	1,68 (.066)	0,30 (.012)
RG188/U	50	2,80 (.110)	2,06 (.081)	1,60 (.063)	0,51 (.020)
RG196/U	50	2,04 (.080)	1,37 (.054)	0,91 (.036)	0,30 (.012)
RG316/U	50	2,60 (.102)	2,06 (.081)	1,60 (.063)	0,51 (.020)
RG402/U	50	-	3,61 (.142)	3,05 (.120)	0,91 (.036)
RG405/U	50	-	2,18 (.086)	1,70 (.067)	0,51 (.020)
TZC75024	75	3,55 (.140)	3,01 (.119)	1,95 (.077)	0,31 (.012)
RG141	50	4,95 (.195)	3,71 (.146)	3,07 (.121)	0,99 (.039)
RG142	50	5,08 (.200)	4,34 (.171)	3,07 (.121)	0,99 (.039)

* Double shielded

PART NUMBER GUIDE



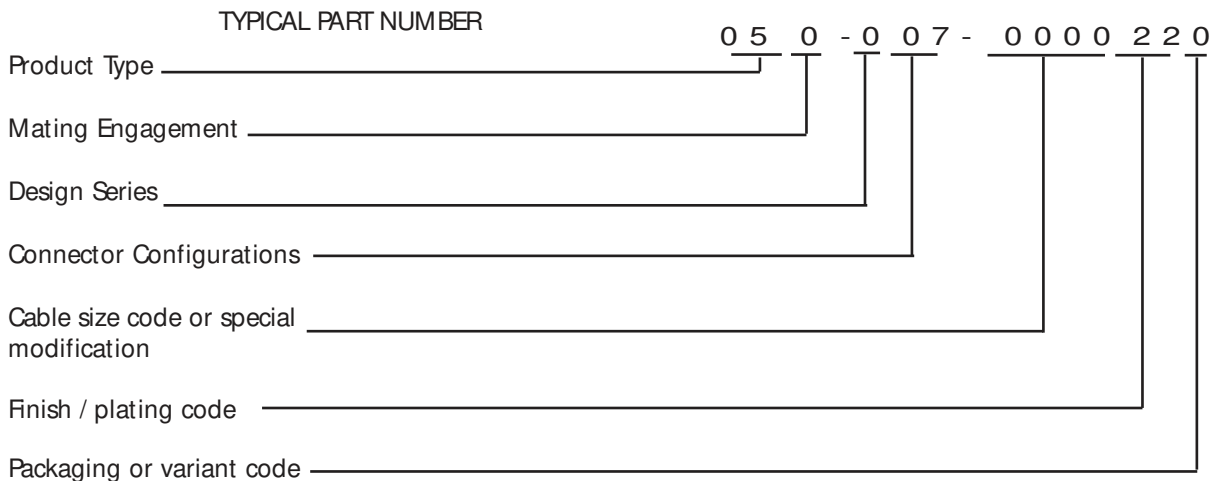



This table shows how the part numbers for coaxial connectors are constructed.





Dimensions shown in mm (inch)
Specifications and dimensions subject to change

www.ittcannon.com

QUICK REFERENCE SELECTION GUIDE

						
Series	SMA Precision	SMA Commercial	SMB	SMC	SSMB	SSMC
Description	Coaxial connector for rugged environments	Robust economical coaxial connectors	Rapid connect /disconnect coaxial connectors	Vibration resistant coaxial connectors	Microminiature rapid connect / disconnect coaxial connectors	Microminiature rapid connect / disconnect coaxial connectors
Frequency	DC - 18 GHz	DC - 18 GHz	DC - 4 GHz	DC - 12.4 GHz	DC - 4 GHz	DC - 4 GHz
Impedance	50Ω	50Ω	50Ω	50Ω	50Ω	50Ω
Cable Type	Flexible/ semi-rigid	Flexible/ semi-rigid	Flexible	Flexible	Flexible	Flexible
Coupling	Screw	Screw	Snap-on	Screw	Snap-on	Screw
Body Material	Stainless steel or beryllium copper	Brass	Brass	Brass	Brass	Brass
Body Finish	Gold or passivated	Gold over nickel	Gold or nickel	Gold or nickel	Gold or nickel	Gold or nickel
Page Number	6	13	19	24	27	31

			
Series	Coaxial Terminators	Between Series Adaptor	SEALFLEX 2™
Description	Provide permanent coaxial connections to printed circuit boards	High efficiency transitions between various coaxial connector series	High performance flexible microwave cable assemblies
Frequency	DC - 4 GHz	DC - 18 GHz	DC - 18 GHz
Impedance	N/A	50Ω	50Ω
Cable Type	Flexible	N/A	Flexible
Coupling	N/A	Various	Screw
Body Material	Copper alloy	Stainless steel or brass	Stainless steel (connectors)
Body Finish	Electroplated tin	Gold or passivated	Passivated (connectors)
Page Number	33	35	37

Dimensions shown in mm (inch)
 Specifications and dimensions subject to change

www.ittcannon.com





Key Features

- Military grade
- Rugged stainless steel design
- Intermateable with all SMAs to Mil-C-39012
- Frequency range DC to 18 GHz

Cannon’s precision SMA connectors feature the MIL-C-39012 Series SMA interface and envelope configuration. They can be mated with all connectors meeting the MIL specification dimensions. Designed for use with a variety of subminiature coaxial cables, superior results are obtained from DC to 18 GHz when used with semi-rigid cables and from DC to 12.4 GHz with flexible cable. These connectors are manufactured with beryllium copper bodies which are gold plated or stainless steel bodies which can be supplied with either a gold plated or passivated finish.

Cannon also offers a range of commercial SMA brass bodied connectors. For further details, please see page 13.

MATING INTERFACES

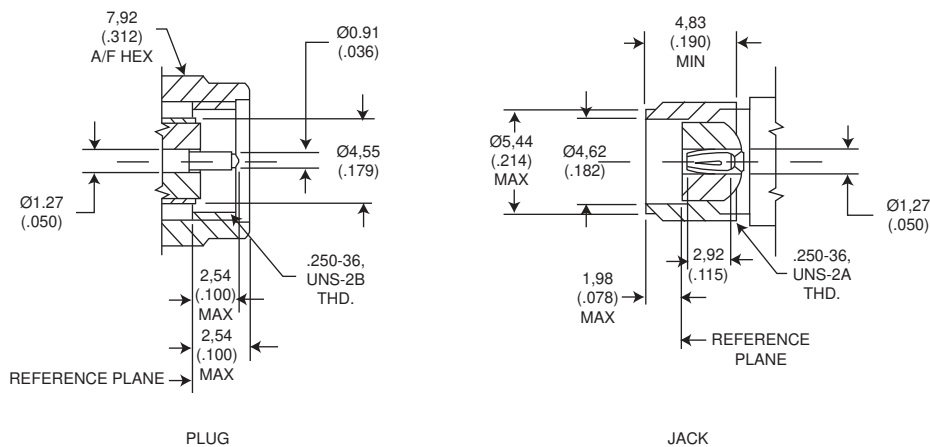

SPECIFICATIONS

ELECTRICAL	Impedance	50Ω nominal		
	Frequency Range	0 to 18.0 GHz		
	Voltage Rating	Connectors for RG178/U series cable: At Sea Level= 170 Vrms At 21km (70k feet) = 45 Vrms Connectors for RG316/U series cable: At Sea Level = 250 Vrms At 21km (70k feet) = 65 Vrms Connectors for RG142/U series cable: At Sea Level = 335 Vrms At 21km (70k feet) = 85 Vrms		
	Insulation Resistance	5000 MΩ minimum		
	Contact resistance	Center Contact = 3.0 m Ω maximum initial. 4.0 m Ω maximum after environment Outer Contact = 2.0 m Ω maximum initial. 2.0 m Ω maximum after environment Braid to Body = 0.5 m Ω maximum		
	Contact Current Rating	2.0 A dc maximum		
	Insertion Loss	0.06 x $\sqrt{\text{freq. GHz}}$ tested at 6 GHz		
	RF Leakage	-60 dB minimum @ 2 - 3 GHz		
	Voltage Standing Wave Ratio (VSWR) To 18 GHz or 80% of upper cut-off frequency of the cable , whichever is lower. Applicable to 50Ω cables only.(F= GHz)	Connector Configuration		
		Cable group	Straight	Right Angle
RG178/U braided		1.20 + .025F	1.20 + .03F	
RG316/U braided		1.15 + .02F	1.15 + .03F	
RG142/U braided		1.15 + .01F	1.15 + .02F	
Dielectric Withstanding Voltage (DWV) Corona Level		Connectors used with RG316/U series cable = 750 Vrms @ Sea Level Connectors used with RG316/U series cable = 190 V @ 21km (70k feet) minimum		
MECHANICAL	Engagement Design	SMA per MIL-C-39012, Series SMA		
	Engagement Forces	Torque: 0.23 Nm (2 in. lbs.) maximum		
	Contact Torque	0.03 Nm (4 in. ozs.) minimum. (For captivated contacts)		
	Mating Torque	0.8 Nm to 1.1 Nm (7 to 10 in. lbs.)		
	Locknut Torque	1.4 Nm to 1.7 Nm (12 to 15 in. lbs.) minimum		
	Coupling Nut Retention	267 N (60 lbs.) minimum		
ENVIRONMENTAL	Materials	Body & Body Components: Non-magnetic stainless steel or beryllium copper. Female Contacts: Beryllium copper. Insulators: PTFE. Crimp Ferrule: Annealed copper alloy. Gaskets: Silicone rubber		
	Finish/Plating	Center Contacts: Gold plated. Other Metal Parts: Gold plated or passivated (as specified) to meet the finish and corrosion requirements of MIL-C-39012		
	Temperature Rating	-65° C to 165° C		
	Corrosion (salt spray)	MIL-STD-202, Method 101, test condition B, 5% salt solution		
	Vibration, High Frequency	MIL-STD-202, Method 204, test condition D (20 G's)		
GENERAL	Shock	MIL-STD-202, Method 213, test condition I (100 G's)		
	Thermal Shock	MIL-STD-202, Method 107, test condition B		
	Moisture Resistance	MIL-STD-202, Method 106. No measurements at high humidity. Insulation resistance shall be 200 M Ω minimum within 5 minutes after removal from humidity.		
	Connector Durability	500 matings minimum		
GENERAL	Contact Captivation	Unless otherwise specified, all connectors feature captivated contacts. When captivated the contacts will withstand 26.7 N (6 lbs.) minimum axial force.		
	Cable Retention	When properly assembled to the compatible single braided coaxial cable, the retention is equal to the breaking strength of the cable.		
	Body Plating Options The following part number suffices can be specified for Precision SMA Connectors 310 gold body, gold coupling nut 890 passivated body & coupling nut except <u>Direct Solder Types</u> ; gold body, passivated coupling nuts			

Dimensions shown in mm (inch)
Specifications and dimensions subject to change



CRIMP TYPE CABLE CONNECTORS FOR FLEXIBLE CABLE

Straight Plug, Non-Captive Contact

Part Number	Cable Numbers
050 - 622 - 9188890	RG174/U, 316/U
050 - 622 - 9875890	FD316

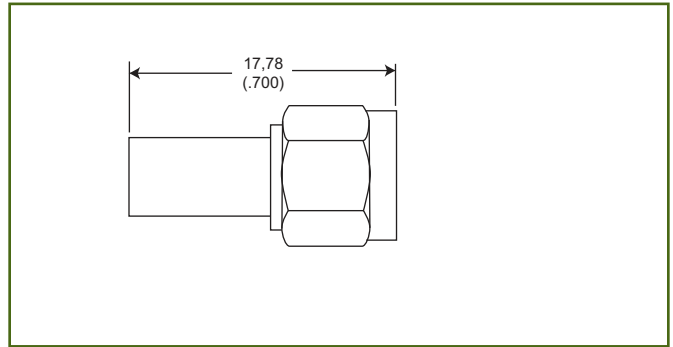

Assembly Instructions AI-102 (Page 43)

Straight Plug, Captive Contact

Part Number	Cable Numbers
A50 - 624 - 9188890	RG174/U, 316/U
A50 - 624 - 9875890	FD316

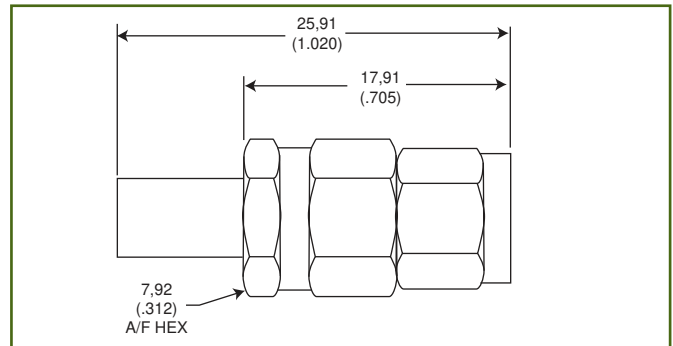

Assembly Instructions AI-703 (Page 51)

Right Angle Plug, Captive Contact

Part Number	Cable Numbers
050 - 628 - 9188890	RG174/U, 316/U
050 - 628 - 9875890	FD316

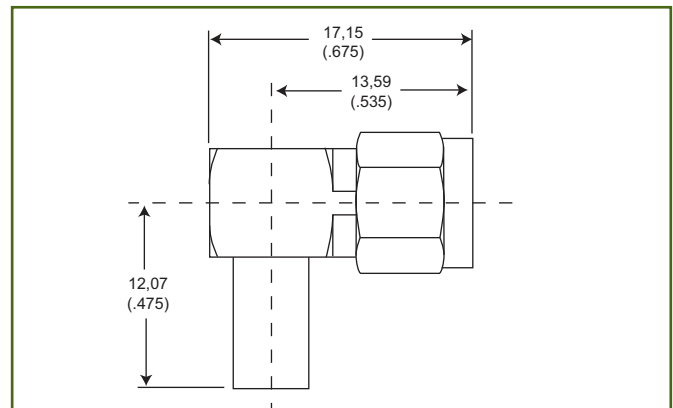

Assembly Instructions AI-90 (Page 41)

Bulkhead Jack, Captive Contact

Part Number	Cable Numbers
050 - 627 - 9188890	RG174/U, 316/U
050 - 627 - 9875890	FD316

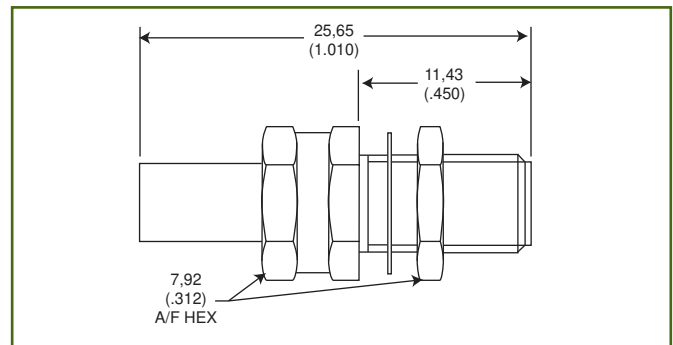

Mounting Plan W (Page 40)
Assembly Instructions AI-227 (Page 46)

The surface finish on these products is passivated stainless steel. For gold plated versions change last three digits of the the part number from 890 to 310.



Dimensions shown in mm (inch)
Specifications and dimensions subject to change

www.ittcannon.com

DIRECT SOLDER TYPE CABLE CONNECTORS FOR SEMI-RIGID CABLE

Straight Plug without Center Contact*

Part Number	Cable Numbers
055 - 607- 2003890	RG402/U

* Center conductor of cable is used as contact

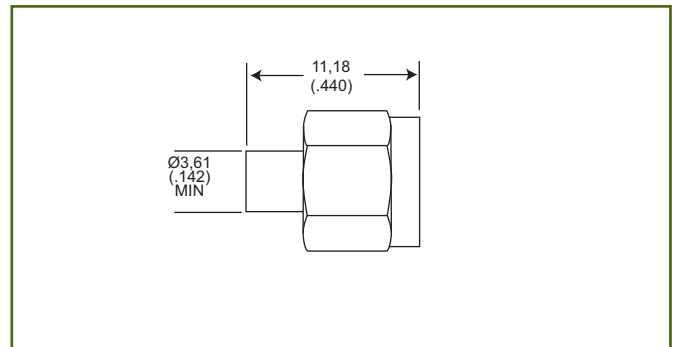

Assembly Instructions AI-302 (Page 48)

Straight Plug with Center Contact

Part Number	Cable Numbers	A
055 - 607- 9172890	RG405/U	2,20 (.088)
055 - 607 - 9173890	RG402/U	3,60 (.142)

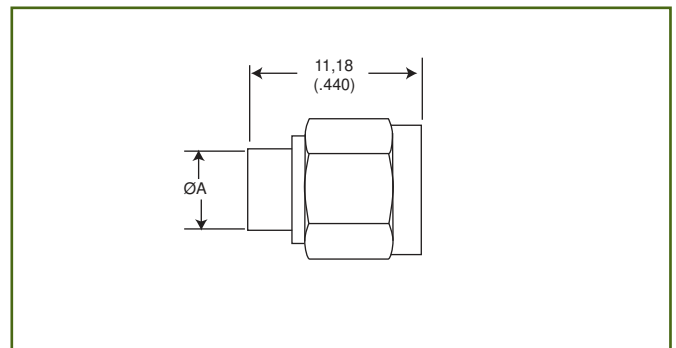

Assembly Instructions AI-252 (Page 47)

Right Angle Plug

Part Number	Cable Numbers	A
055 - 611- 3702890	RG405/U	2,20 (.088)
055 - 611- 3703890	RG402/U	3,60 (.142)

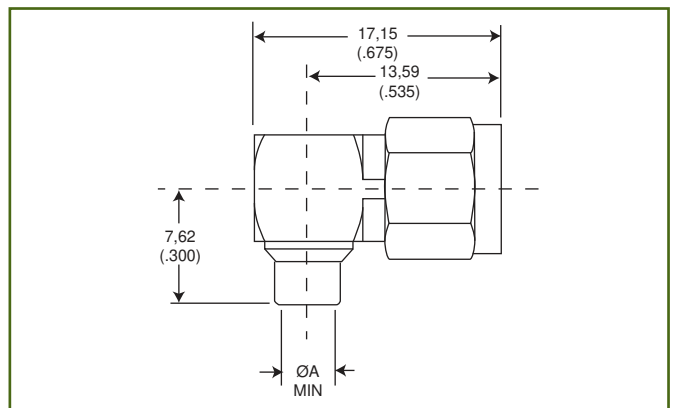

Assembly Instructions AI-98 (Page 42)

The surface finish on these products is passivated stainless steel. For gold plated versions change last three digits of the the part number from 890 to 310.

FLANGE MOUNT RECEPTACLES

Straight Jack, Stub Contact, Extended Dielectric

Part Numbers	
Square Flange	Narrow Flange
050 - 645 - 9009890	050 - 645 - 4540890

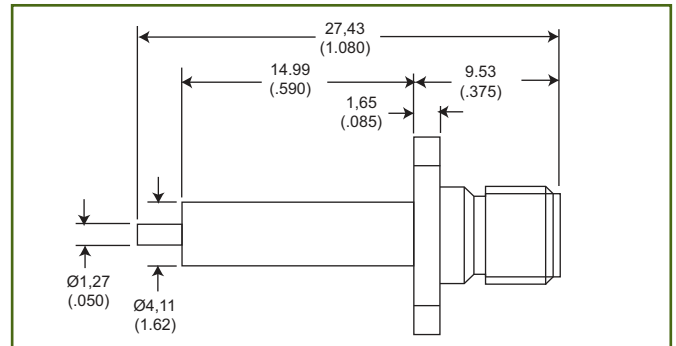

Straight Jack, Solder Pot Contact, Flush Dielectric

Part Numbers	
Square Flange	Narrow Flange
050 - 645 - 9019890	Contact Customer Service

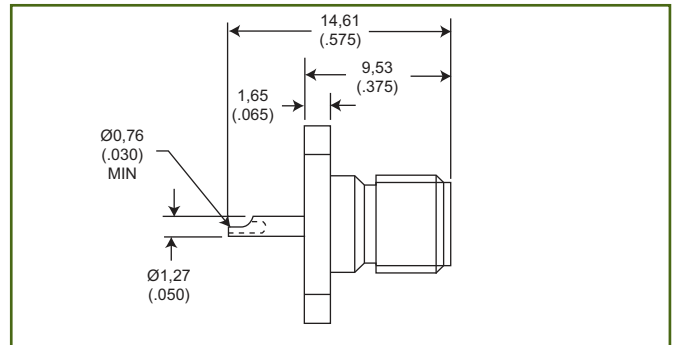

Straight Jack, Tab Contact, Flush Dielectric

Part Numbers	
Square Flange	Narrow Flange
050 - 645 - 4575890	050 - 645 - 4528890

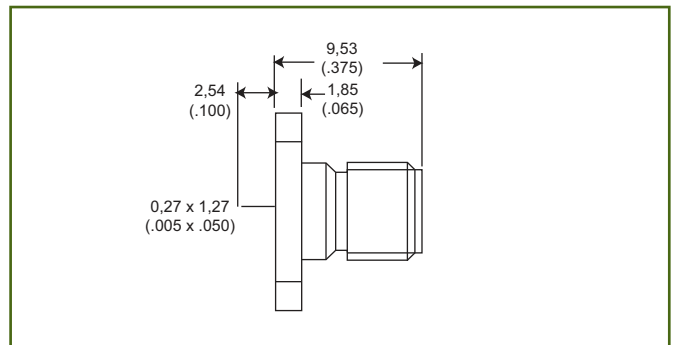

Flange Dimensions for Flange Mount Receptacles and Panel Jacks

ALL FLANGE MOUNT RECEPTACLES HAVE CAPTIVATED CONTACTS

The surface finish on these products is passivated stainless steel. For gold plated versions change last three digits of the the part number from 890 to 310.

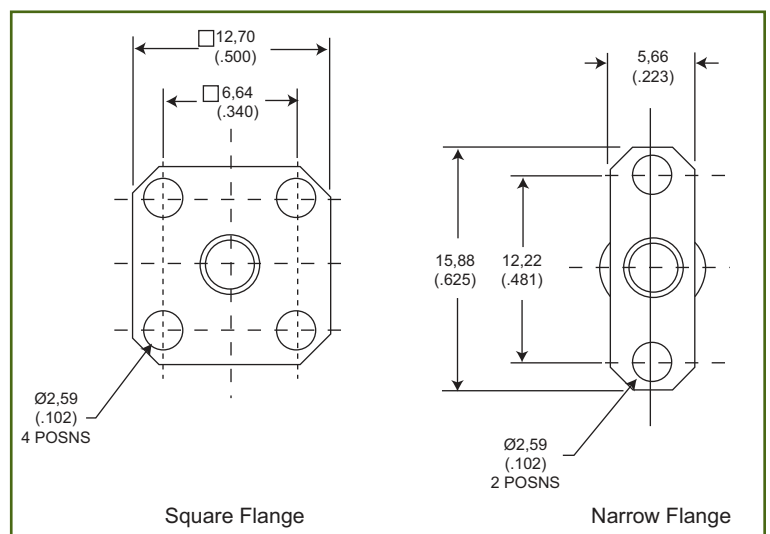

Dimensions shown in mm (inch)
Specifications and dimensions subject to change

www.ittcannon.com

PRINTED CIRCUIT RECEPTACLES

Straight Jack

Part Number
050 - 651 - 0000310

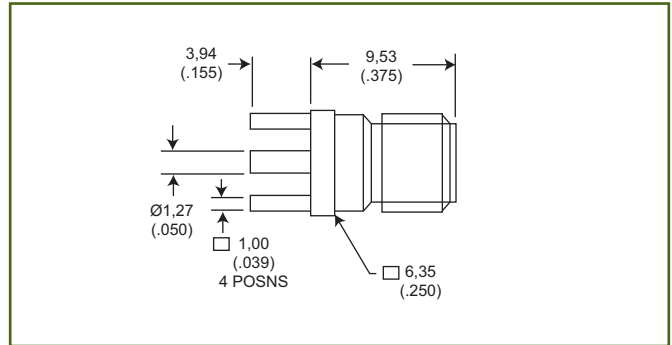

Mounting Plan D (Page 40)

Right Angle Jack

Part Number
050 - 653 - 0000310

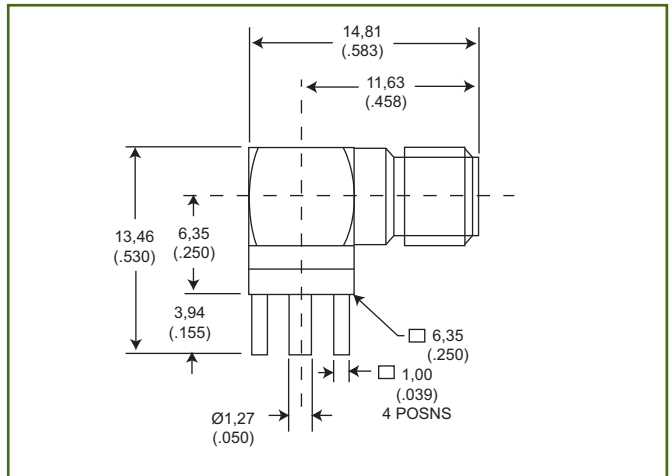

Mounting Plan D (Page 40)

IN-SERIES ADAPTORS

Plug to Plug Adaptor, Straight

Part Number

050 - 673 - 0000890

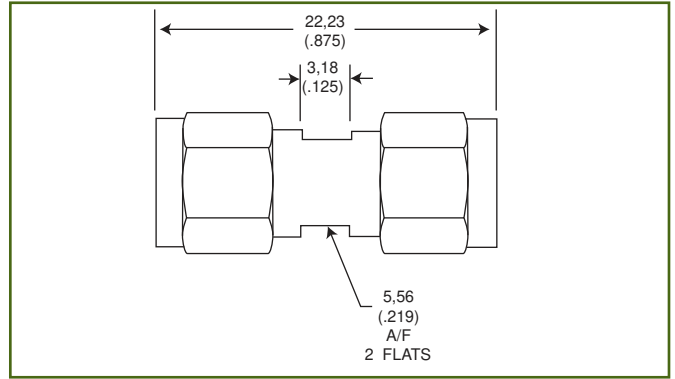

Plug to Jack Adaptor, Straight

Part Number

050 - 674 - 0000890

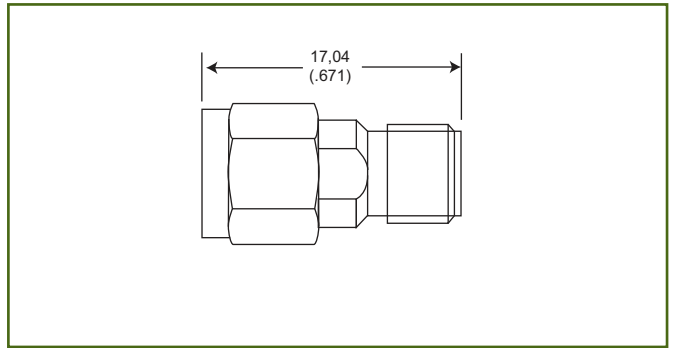

Jack to Jack Adaptor, Bulk Head Mount, Straight

Part Number

050 - 675 - 0000890

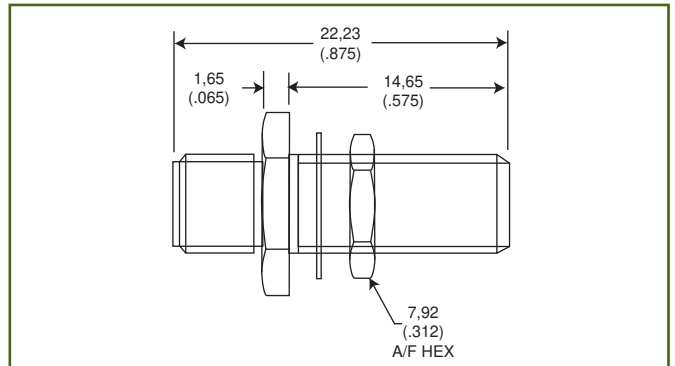

Mounting Plan W (Page 40)

Plug to Jack Adaptor, Right Angle

Part Number

050 - 678 - 0000890

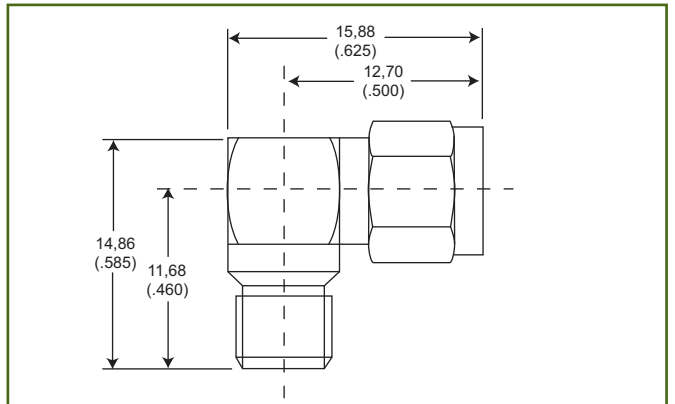

The surface finish on these products is passivated stainless steel. For gold plated versions change last three digits of the the part number from 890 to 310.



Dimensions shown in mm (inch)
Specifications and dimensions subject to change

www.ittcannon.com

Cannon’s Commercial SMA connectors are subminiature devices that provide repeatable electrical performance through the frequency range DC to 18.0 GHz. These 50 ohm connectors offer minimum attenuation with low reflection which makes them extremely popular in the RF and microwave industry. The MIL-C-39012 series SMA interface ensures they can be mated with all connectors meeting the MIL specification dimensions. They are designed for use with a variety of subminiature coaxial cables. This includes semi-rigid and hand formable cables as well as the popular RG series of flexible cable and commercial cables meeting these dimensions.



These SMA connectors feature stand-off legs on the PCB mount designs to enhance soldering, cleaning and inspection. The straight plugs feature crimp / solder contacts for speed of assembly and high performance. SMA connectors are found in many diverse applications including amplifiers, dividers, filters and attenuators.

Key Features

- Crimp /solder contacts on straight plugs and bulkhead jacks
- Stand-off legs on PCB mounts
- Intermateable with all SMAs to MIL-C-39012

The standard units are supplied in gold plate. Nickel plated versions are available on request.

MATING INTERFACES

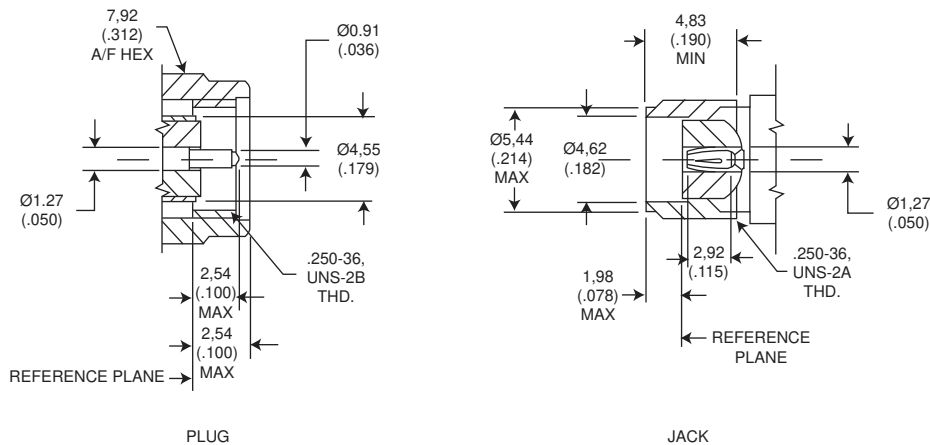

Dimensions shown in mm (inch)
 Specifications and dimensions subject to change



SPECIFICATIONS

ELECTRICAL	Impedance	50Ω		
	Frequency Range	0 to 18.0 GHz		
		for RG-402 & RG-405 semi-rigid cable - 0 to 18 GHz		
			for flexible cable - 0 to the maximum frequency of the cable per MIL-C-17	
	Voltage Rating	RG402 (0.141" OD.)	550 volts rms maximum	
		RG405 (0.085" OD.)	335 volts rms maximum	
		RG58, 141, 142, 223	550 volts rms maximum	
		RG174, 188, 316	335 volts rms maximum	
	Insulation Resistance	5000 MΩ minimum		
	Contact Resistance	Center Contact = 5.0 mΩ maximum		
		Outer Contact = 1.0 mΩ maximum		
	Insertion Loss	0.04 dB maximum x \sqrt{f} GHz (straight)		
		0.06 dB maximum x \sqrt{f} GHz (right angle)		
	RF Leakage	-(90-f GHz) dB minimum		
	Voltage Standing Wave Ratio (VSWR)	1.05+ 0.15 x f GHz maximum (straight)		
1.15+ 0.15 x f GHz maximum (right angle)				
RG402 (0.141" OD)		1.05+ 0.005 x f GHz maximum		
RG405 (0.085" OD)		1.05+ 0.005 x f GHz maximum		
RG58, 141, 142, 223		1.10+ 0.01 x f GHz maximum (straight)		
		1.15+ 0.02 x f GHz maximum (right angle)		
RG174, 188, 316		1.15+ 0.01 x f GHz maximum (straight)		
Dielectric Withstanding Voltage	1.18+ 0.02 x f GHz maximum (right angle)			
	RG402 (0.141" OD)	1000 volts rms maximum		
	RG405 (0.085" OD)	750 volts rms maximum		
	RG58, 141, 142, 223	1000 volts rms maximum		
	RG174, 188, 316	750 volts rms maximum		
MECHANICAL & ENVIRONMENTAL				
Mating	1/4" - 36 threaded coupling			
Durability	500 matings			
Coupling Nut Retention	Minimum 60 lbs			
Recommended Nut Mating Torque	8 inch-pounds			
Cable Retention	RG58, 141, 142, 223 40 lbs minimum			
	RG174, 188, 316	20 lbs minimum		
Temperature Range	-65° C to 165° C			
Vibration	MIL-STD-202 Method 204 test condition D			
Salt Spray	MIL-STD-202, Method 101, test condition B			
Temperature Cycling	MIL-STD-202, Method 102 test condition C			
MATERIAL				
Connector Body	Material	Plating		
	Brass	Gold or nickel		
Center Contact	Male: Brass	Gold over nickel		
	Female: beryllium-copper	Gold over nickel		
Insulation	Teflon	None		
Gasket	Silicone	None		
Crimp Ferrule	Annealed Copper	Same as body		



Dimensions shown in mm (inch)
Specifications and dimensions subject to change

www.ittcannon.com

CRIMP ATTACHMENTS FOR FLEXIBLE CABLE

Straight Crimp Plug

Part Number	Cable Numbers
F50 - E22 - 9141000	RG141
F50 - E22 - 9142000	RG142

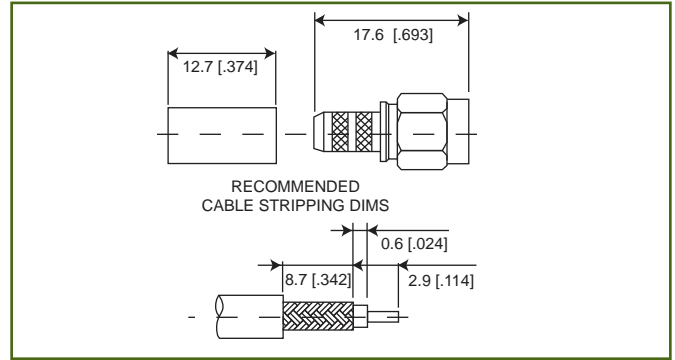

Assembly Instructions CSMA 1 (Page 54)

Straight Crimp Plug

Part Number	Cable Numbers
F50 - E22- 9188000	RG316
F50 - E22 - 9875000	RD316

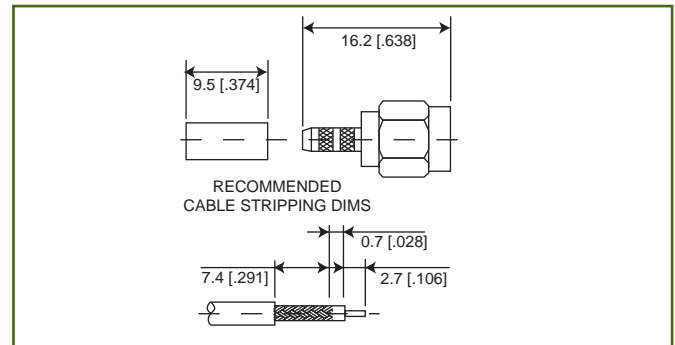

Assembly Instructions CSMA 1 (Page 54)

Right Angle Crimp Plug

Part Number	Cable Numbers
F50 - E28 - 9141000	RG141
F50 - E28 - 9142000	RG142

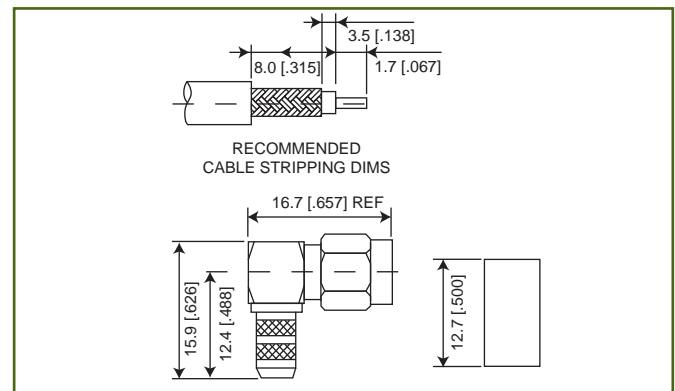

Assembly Instructions CSMA 2 (Page 54)

Right Angle Crimp Plug

Part Number	Cable Numbers
F50 - E28 - 9188890	RG316
F50 - E28 - 9875000	RD316

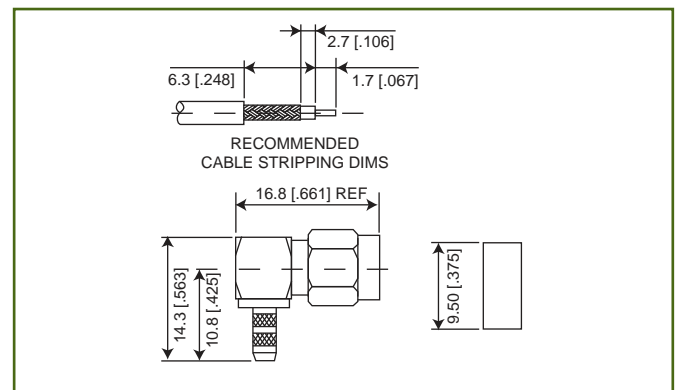

Assembly Instructions CSMA 2 (Page 54)

Dimensions shown in mm (inch)
 Specifications and dimensions subject to change
www.ittcannon.com



CRIMP ATTACHMENTS FOR FLEXIBLE CABLE

Bulkhead Crimp Jack

Part Number	Cable Numbers
F50 - E27 - 9188000	FG316
F50 - E27 - 9875000	FD316

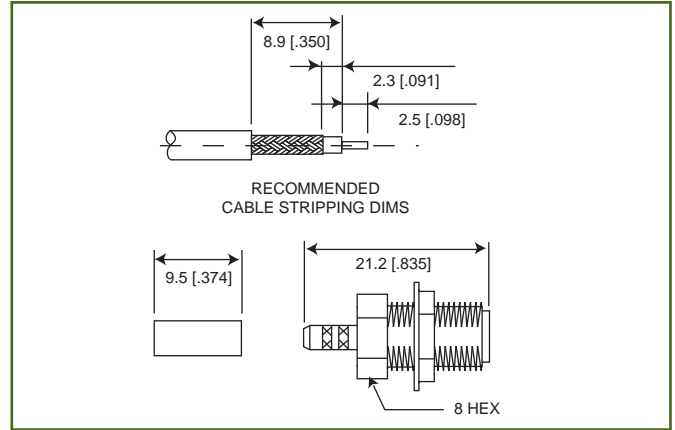

Assembly Instructions CSMA 1 (Page 54)
Panel Mounting Plan W (Page 40)

PRINTED CIRCUIT BOARD

Straight Jack for Printed Circuit Board

Part Number	Cable Numbers
F50 - E51- 0000000	N/A

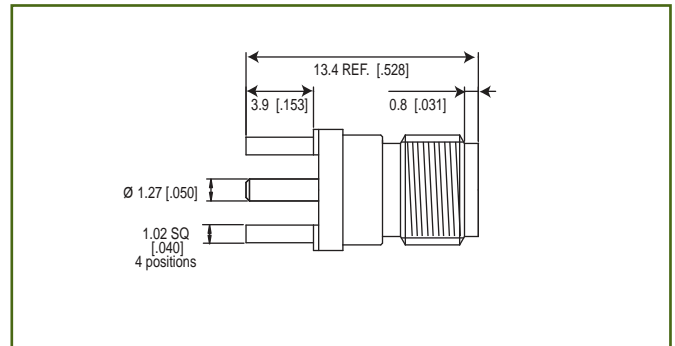

PCB Mounting Plan D (Page 40)

Right Angle Jack for Printed Circuit Board

Part Number	Cable Numbers
F50 - E53- 0000000	N/A

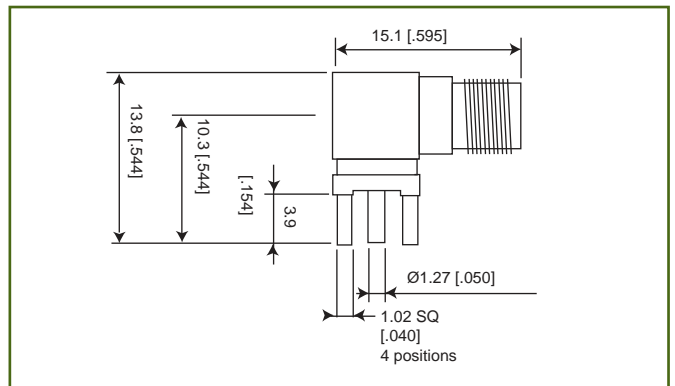

PCB Mounting Plan D (Page 40)



DIRECT SOLDER FOR SEMI-RIGID CABLE

Straight Cable Plug Without Contact

Part Number	Cable Numbers
F55 - E07- 2003000	RG402

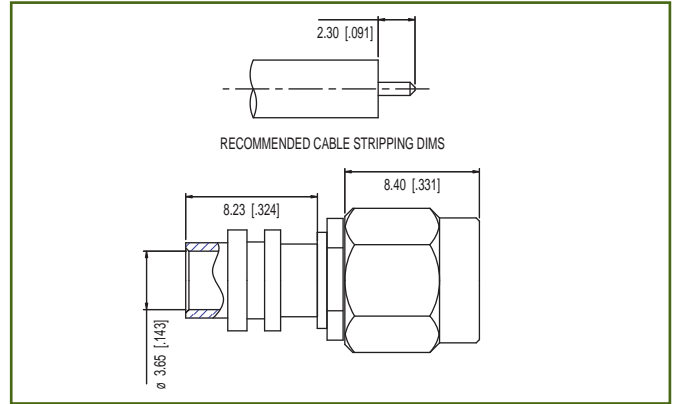

Assembly Instructions CSMA 3 (Page 55)

Straight Cable Plug With Contact

Part Number	Cable Numbers
F55 - E07 - 9172000	RG405
F55 - E07 - 9173000	RG402

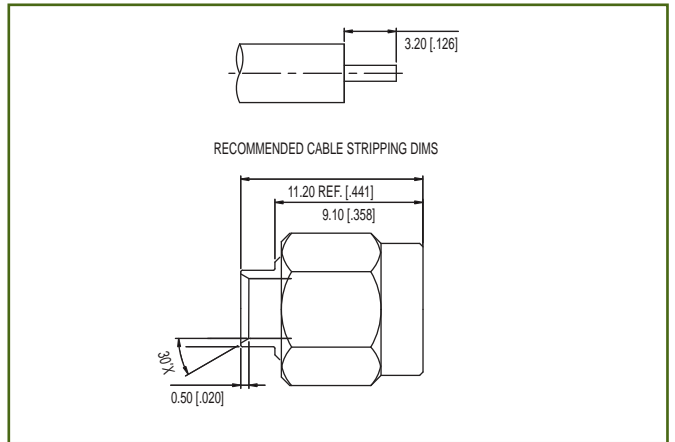

Assembly Instructions CSMA 4 (Page 56)

Right Angle Cable Plug

Part Number	Cable Numbers	A	B
F55 - E11 - 3702000	RG405	8,1 [.319]	4,6 [.181]
F55 - E11 - 3703000	RG402	11,5 [.453]	8,1 [.319]

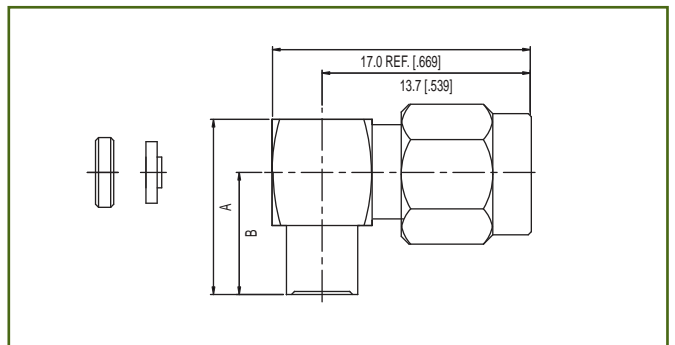

Assembly Instructions CSMA 5 (Page 57)

Dimensions shown in mm (inch)
 Specifications and dimensions subject to change

The designs shown in this catalogue are not the entire range. Examples of some of the many styles that are available on request are shown below. Should you require styles that are not shown please contact our nearest sales department listed on the back cover.

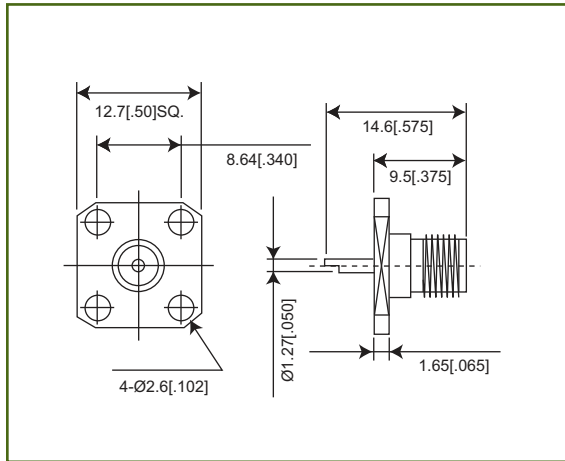

Panel Mount Jack - Solder Pot Contact

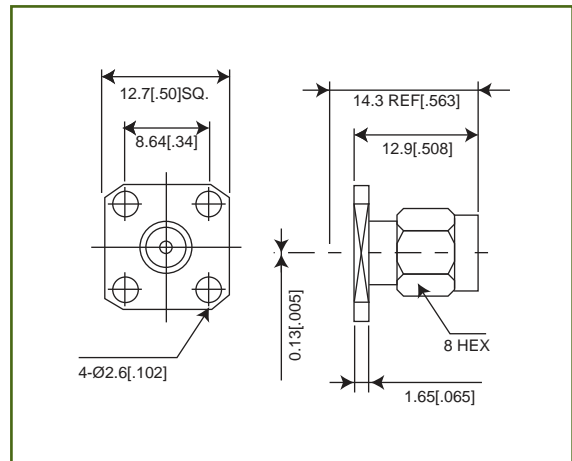

Panel Mount Plug - Tab Contact

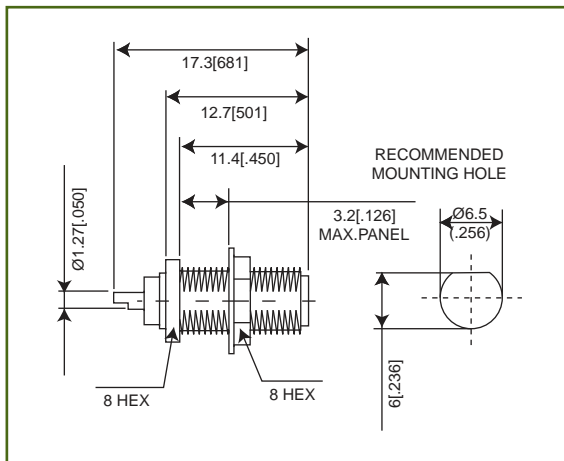

Bulkhead Mount Jack - Solder Pot Contact

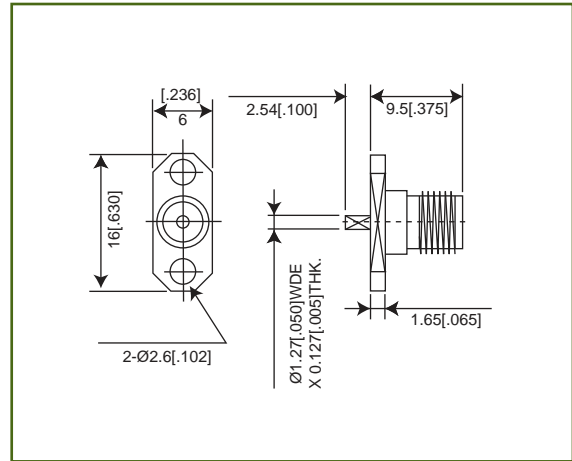

Panel Mount Plug - Tab Contact

Cannon's SMB Snap-on and SMC Screw-on subminiature coaxial connectors have been specifically engineered for high performance and high reliability applications in both military and commercial equipment operating at frequencies up to 4 GHz (SMB) and 12.4 GHz (SMC).

The Snap-on mating engagement allows a rapid connect/disconnect facility. The Screw-on mating engagement allows a low VSWR under vibration conditions and a matched impedance of 50 ohms.

Cannon SMB/SMC connectors are compatible with all SMB/SMC type connectors conforming with MIL-C-39012, BS 9210, UTE C93 561, UTE C93 562, CECC 22 130 and CECC 22 140.

In addition to this range we also offer FAKRA SMB connectors for automotive applications.



Key Features

- Rapid connect / disconnect (SMB)
- Standoff legs on PCB
- Frequency range to 12.4 GHz (SMC) or 4 GHz (SMB)
- Vibration withstanding design (SMC)

MATING INTERFACES

SMB (SNAP-ON)

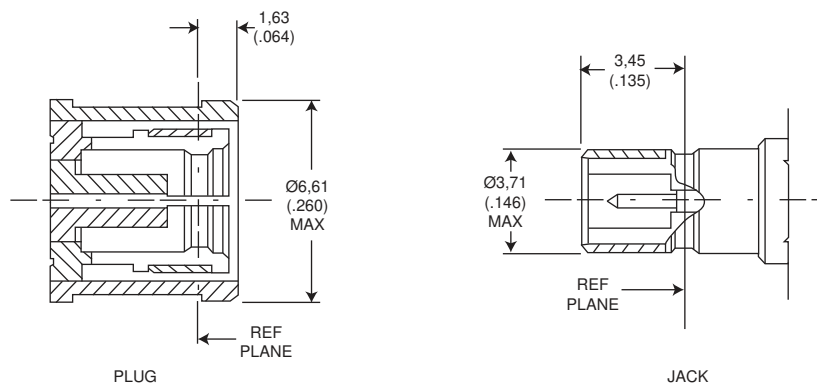

SMC (SCREW-ON)

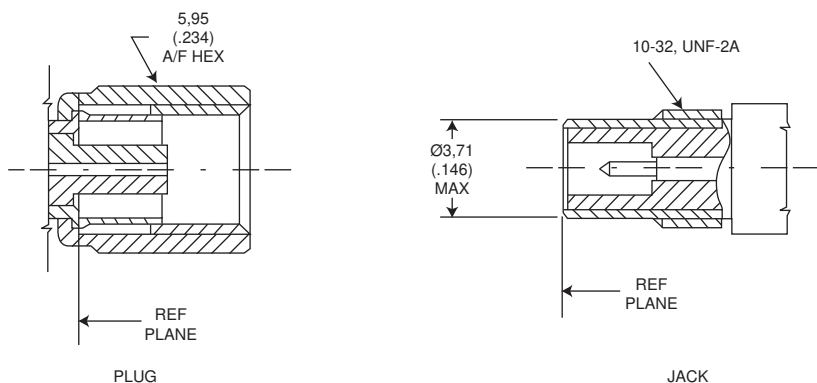

NOTES

1) Inside diameter of female contact to meet VSWR mating characteristics and connector durability when mated with a $0,48 \pm 0,53$ ($.019 \pm .021$) diameter male contact.

2) All undimensioned pictorial representations are for reference purposes only.

3) Side-on versions of most SMB female styles, prefix 052, are available. For slide-on male interconnection use male SMB (snap-on type).

Dimensions shown in mm (inch)
Specifications and dimensions subject to change

www.ittcannon.com



SPECIFICATIONS

ELECTRICAL	Impedance	50Ω																											
	Frequency Range	SMB = 0 to 4.0 GHz. SMC = 0 to 12.4 GHz																											
	Voltage Rating	Connectors for RG196/U series cable: At Sea Level = 300 Vrms. At 21km (70k feet) = 75 Vrms Connectors for RG188/U series cable: At Sea Level = 400 Vrms. At 21km (70k feet) = 100 Vrms																											
	Insulation Resistance	1000 MΩ minimum																											
	Contact resistance	Center Contact = 6.0 m Ω maximum initial. 8.0 m Ω maximum after environment Outer Contact = 1.0 m Ω maximum initial. 1.5 m Ω maximum after environment Braid to Body = 1.0 m Ω maximum																											
	Contact Current Rating	1.5 A dc maximum																											
	Insertion Loss	0.25 dB maximum @ 4 GHz																											
	RF Leakage	SMB = -55 dB minimum @ 2 - 3 GHz SMC = -60 dB minimum @ 2 - 3 GHz																											
	Voltage Standing Wave Ratio (VSWR) To 10 GHz or 80% of upper cut-off frequency of the cable, whichever is lower. Applicable to 50Ω cables only.(F= GHz)	<table border="1"> <thead> <tr> <th rowspan="2"></th> <th colspan="4">Connector Configuration</th> </tr> <tr> <th colspan="2">SMB</th> <th colspan="2">SMC</th> </tr> <tr> <th>Cable group</th> <th>Straight</th> <th>Right Angle</th> <th>Straight</th> <th>Right Angle</th> </tr> </thead> <tbody> <tr> <td>RG196/U Series</td> <td>1.30 + .04F</td> <td>1.45 + .06F</td> <td>1.25 + .04F</td> <td>1.40 + .06F</td> </tr> <tr> <td>RG188/U Series</td> <td>1.20 + .04F</td> <td>1.35 + .04F</td> <td>1.20 + .04F</td> <td>1.30 + .04F</td> </tr> </tbody> </table>					Connector Configuration				SMB		SMC		Cable group	Straight	Right Angle	Straight	Right Angle	RG196/U Series	1.30 + .04F	1.45 + .06F	1.25 + .04F	1.40 + .06F	RG188/U Series	1.20 + .04F	1.35 + .04F	1.20 + .04F	1.30 + .04F
		Connector Configuration																											
SMB		SMC																											
Cable group	Straight	Right Angle	Straight	Right Angle																									
RG196/U Series	1.30 + .04F	1.45 + .06F	1.25 + .04F	1.40 + .06F																									
RG188/U Series	1.20 + .04F	1.35 + .04F	1.20 + .04F	1.30 + .04F																									
MECHANICAL	Engagement Design	SMB per MIL-C-39012, Series SMB. SMC per MIL-C-39012, Series SMC.																											
	Engagement Forces	SMB: Initial = 62 N (14 lbs.) max. engagement. After 500 matings = 62 N (14 lbs.) max. engagement and disengagement = 8.9 N (2 lbs.) min. disengagement. SMC: 0.11 Nm (16 in. oz.) torque max.																											
	Mating Torque	SMB: N/A SMC: 0.42 to 0.50 Nm (60 to 70 in.oz)																											
	Locknut Torque	0.56 to 0.64 Nm (80 to 90 in. oz)																											
	Coupling Nut Retention	SMB: N/A SMC: 155 N (35 lbs.) minimum																											
	Materials	Body, Body Components and Male Contacts: Brass, half hard. Female Contacts: Beryllium Copper, heat treated. Insulators: PTFE. Lockwashers: Phosphor Bronze. Crimp Ferrule: Annealed copper alloy. Gaskets: Silicone rubber																											
ENVIRONMENTAL	Finish/Plating	Center Contacts: Gold plated. Other Metal Parts: Gold plated or nickel plated (as specified) to meet the finish and corrosion requirements of MIL-C-39012																											
	Temperature Rating	-65° C to 165° C																											
	Corrosion (salt spray)	MIL-STD-202, Method 101, test condition B, 5% salt solution																											
	Vibration, High Frequency	MIL-STD-202, Method 204, SMB: test condition B (15 G's). SMC: test condition D (20 G's)																											
	Shock	MIL-STD-202, Method 213, SMB: test condition B, 75 G's @ 6 milliseconds, 1/2 sine. SMC: test condition C, 100 G's @ 6 milliseconds, 1/2 sine.																											
	Thermal Shock	MIL-STD-202, Method 107, test condition B, except high temperature shall be 85° C High temperature shall be 200° C for connectors using 200° C cables.																											
GENERAL	Moisture Resistance	MIL-STD-202, Method 106, when interface gasket is used. No measurement at high humidity. Insulation resistance shall be 200 MΩ minimum within five minutes after removal from humidity.																											
	Connector Durability	500 matings minimum																											
	Contact Captivation	Unless otherwise specified, all connectors feature captivated contacts. When captivated the contacts will withstand 17,8 N (4 lbs.) minimum axial force. CECC 22 130 = 10 N(2.25 lb.)																											
	Cable Retention	When properly assembled to the compatible single braided coaxial cable, the retention is equal to the breaking strength of the cable.																											
	Body Plating Options	The following part number suffices can be specified for SMB/SMC Connectors: 220 gold body 910 nickel body C90 nickel body																											

STRAIGHT PLUGS AND JACKS

Straight Crimp Plug

Part Number	Cable Numbers
B51 - 024 - 0000220	RG174/U, 316/U
B51 - 024 - 3196220	RG178/U, 196/U
B51 - 024 - 9399220	FD316, 179

Straight Crimp Bulkhead Jack

Part Number	Cable Numbers
051 - 027 - 0000220	RG174/U, 316/U
051 - 027 - 3196220	RG178/U, 196/U
051 - 027 - 9399220	FD316, 179

RIGHT ANGLE PLUGS

Right Angle Crimp Plug

Part Number	Cable Numbers
B51 - 328 - 3188220	RG174/U, 316/U
B51 - 328 - 3196220	RG178/U, 196/U
B51 - 328 - 9399220	FD316, 179
B51 - 328 - 9019AU0	BT3002, T2C75024

IN-SERIES ADAPTORS

Jack to Jack Adaptor, Bulkhead Mounting

Part Number
051 - 075 - 0000220

SMB connectors have solder center contacts.

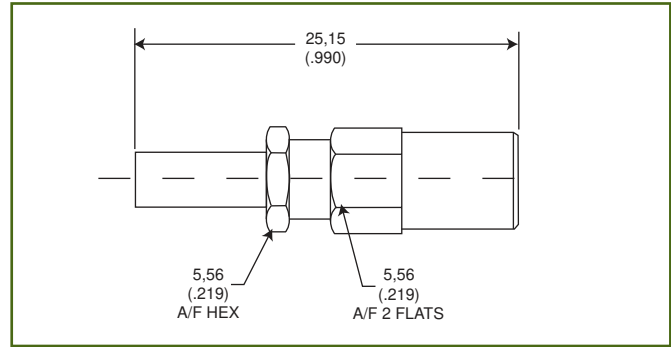

Assembly Instructions BAI-003 (Page 50)

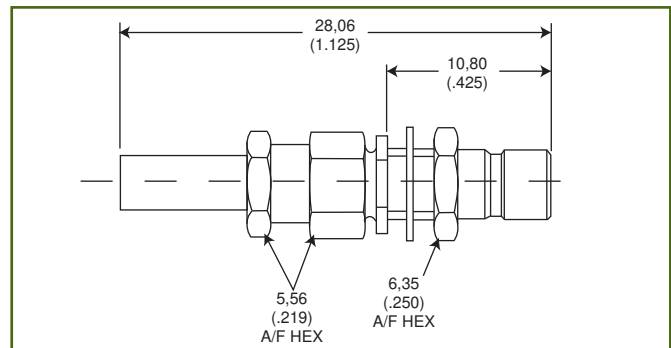

Mounting Plan V (Page 40)
Assembly Instructions BAI-003 (Page 50)

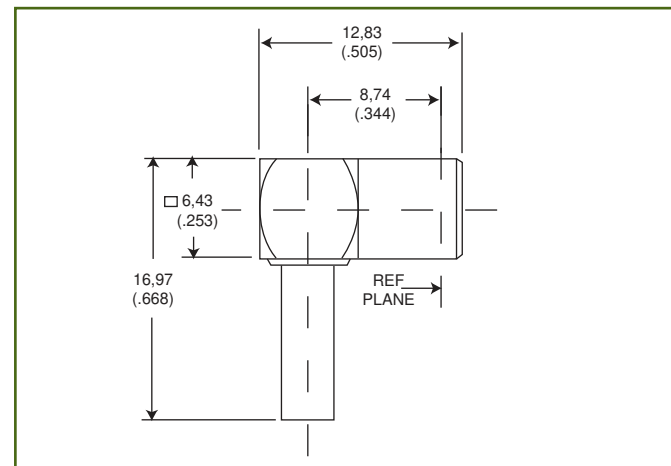

Assembly Instructions BAI-015 (Page 49)

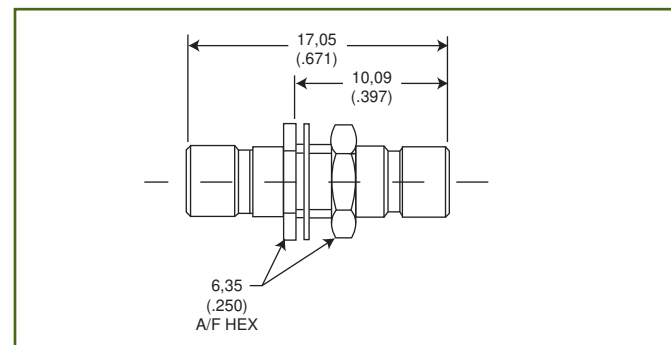

Mounting Plan V (Page 40)



Dimensions shown in mm (inch)
Specifications and dimensions subject to change
www.ittcannon.com

BULKHEAD JACKS

Straight Bulkhead Jack, Solder Pot,
Mounting Nut Outside Panel

Part Number
051 - 043 - 0000220

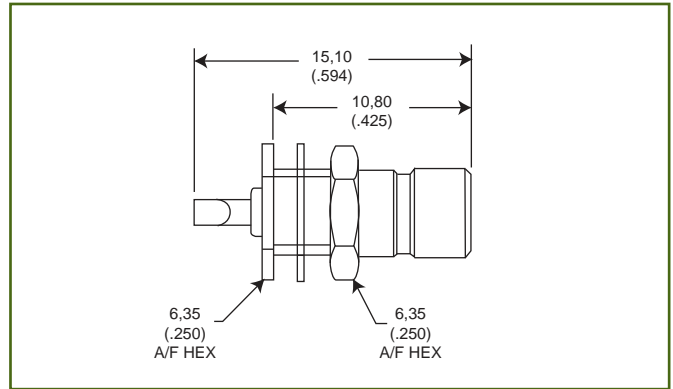

Mounting Plan V (Page 40)

Straight Bulkhead Jack, Solder Pot,
Mounting Nut Inside Panel

Part Number
051 - 045 - 0000220

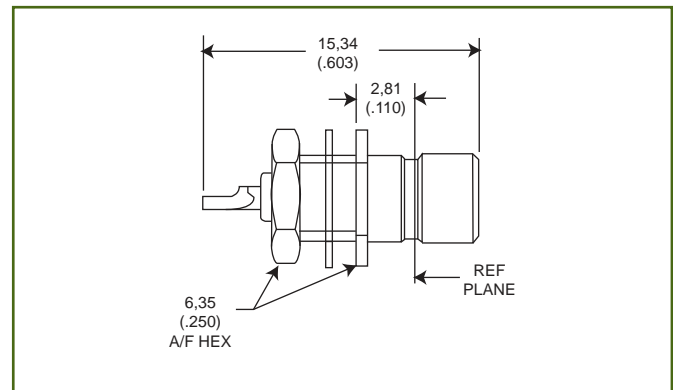

Mounting Plan V (Page 40)

Right Angle Bulkhead Jack, Solder Pot,
Mounting Nut Inside Panel

Part Number
051 - 047 - 0000220

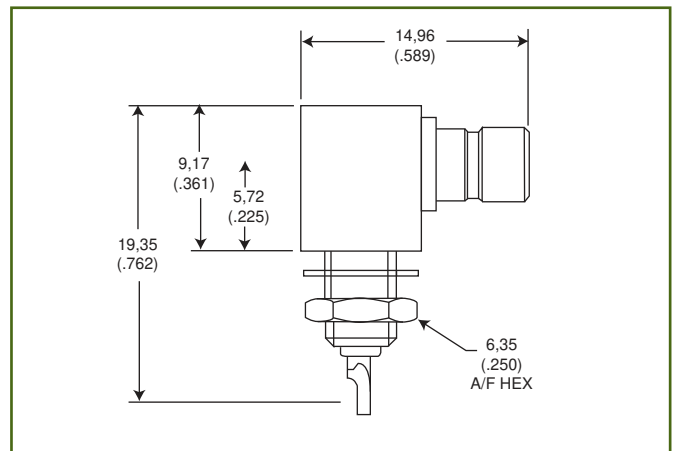

Mounting Plan V (Page 40)



PRINTED CIRCUIT BOARD JACKS

SMB PCB preferred styles feature stepped legs. This allows the jacks to be raised from the surface of the PCB, thereby preventing the accumulation of soldering fluids and foreign bodies. A single piece conductor overcomes the problem of internal joint separation during continuous wave / flow soldering operations.

Straight PCB Jack, 1,00 (.039) sq Legs

Part Number

B51 - 351 - 0000220

Straight PCB Jack, 0,81 (.032) sq Legs

Part Number

B51 - 051 - 9029220

Right Angle PCB Jack, 1,00 (.039) sq Legs

Part Number

B51 - 053 - 0000220

Right Angle PCB Jack, 0,81 (.032) sq Legs

Part Number

B51 - 053 - 9029220

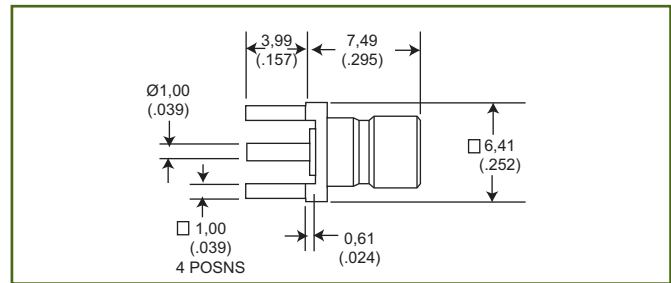

Mounting Plan A (Page 40)

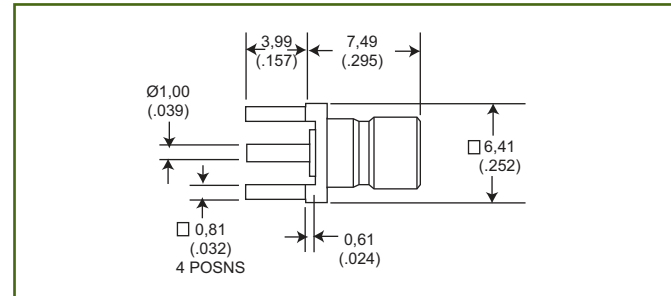

Mounting Plan B (Page 40)

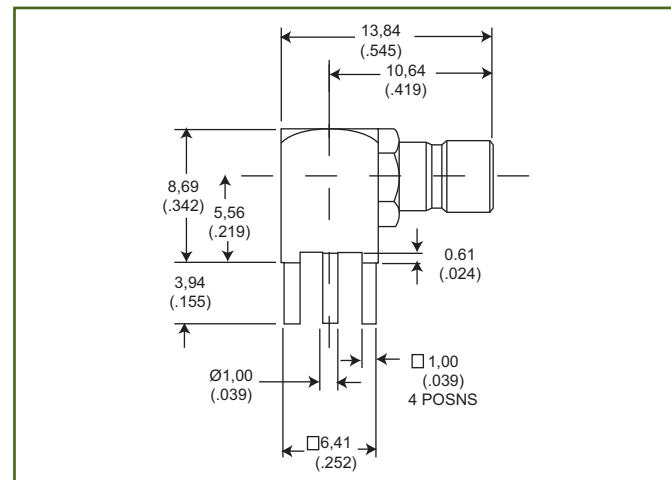

Mounting Plan A (Page 40)

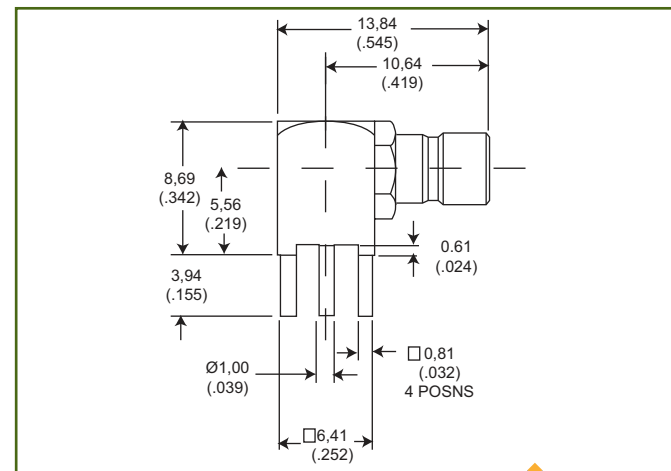

Mounting Plan B (Page 40)



Dimensions shown in mm (inch)
Specifications and dimensions subject to change

STRAIGHT PLUGS AND JACKS

Straight Clamp Plug

Part Number	Cable Numbers
050 - 007 - 0000220	RG174/U, 316/U

Straight Crimp Plug

Part Number	Cable Numbers
050 - 024 - 0000220	RG174/U, 316/U

Straight Crimp Bulkhead Jack

Part Number	Cable Numbers
050 - 027 - 0000220	RG174/U, 316/U

RIGHT ANGLE PLUGS

Right Angle Crimp Plug

Part Number	Cable Numbers
B50 - 328 - 3188220	RG174/U, 316/U
B50 - 328 - 9399220	FD316, 179

SMC CONNECTORS HAVE SOLDER CENTER CONTACTS

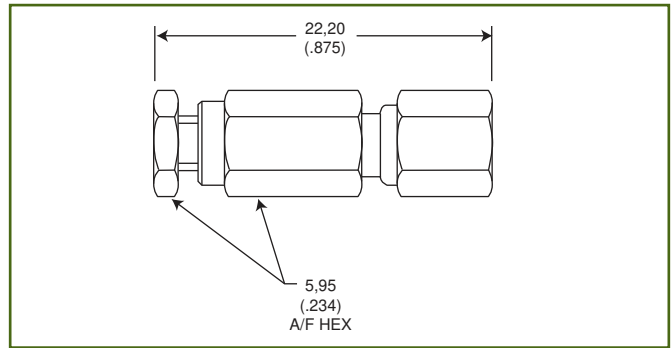

Assembly Instructions BAI-001 (Page 52)

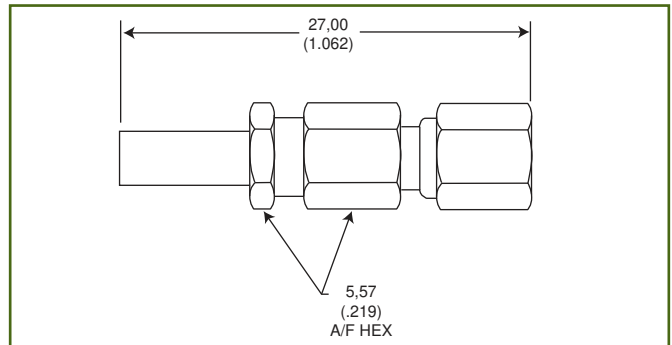

Assembly Instructions BAI-003 (Page 50)

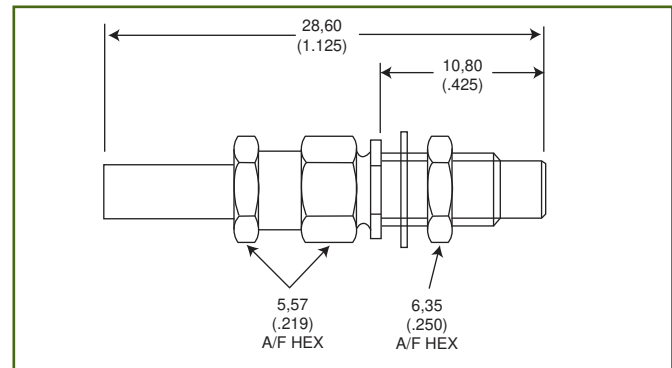

Mounting Plan V (Page 40)
Assembly Instructions BAI-003 (Page 50)

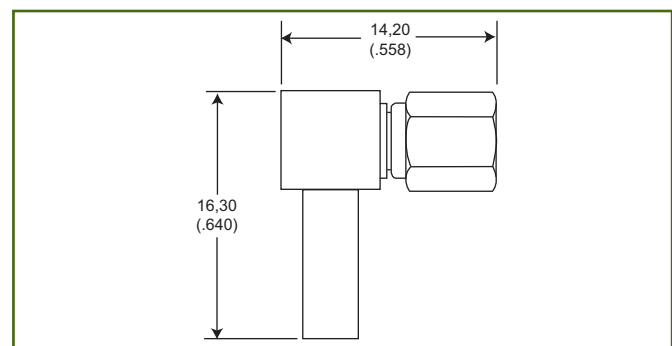

Assembly Instructions
BAI-015 (Page 49)



BULKHEAD JACKS

Straight Bulkhead Jack, Solder Pot,
Mounting Nut outside Panel

Part Number
050 - 043 - 0000220

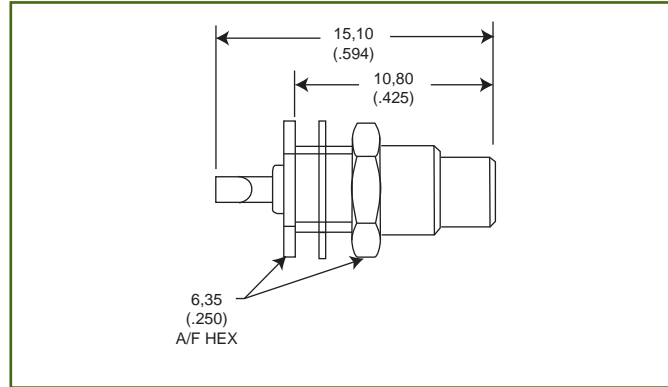

Mounting Plan V (Page 40)

Straight Bulkhead Jack, Solder Pot ,
Mounting Nut inside Panel

Part Number
050 - 045 - 0000220

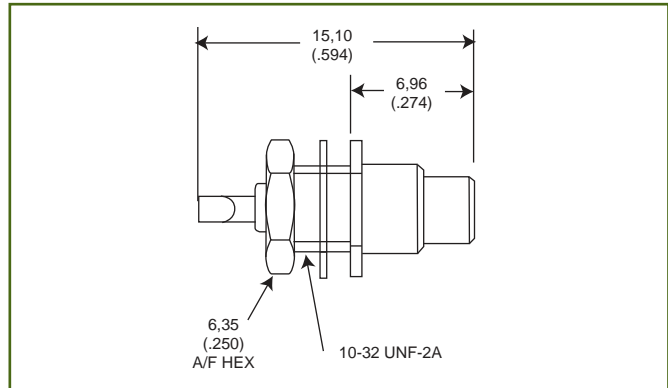

Mounting Plan V (Page 40)

Right Angle Bulkhead Jack, Solder Pot,
Mounting Nut inside Panel

Part Number
050 - 047 - 0000220

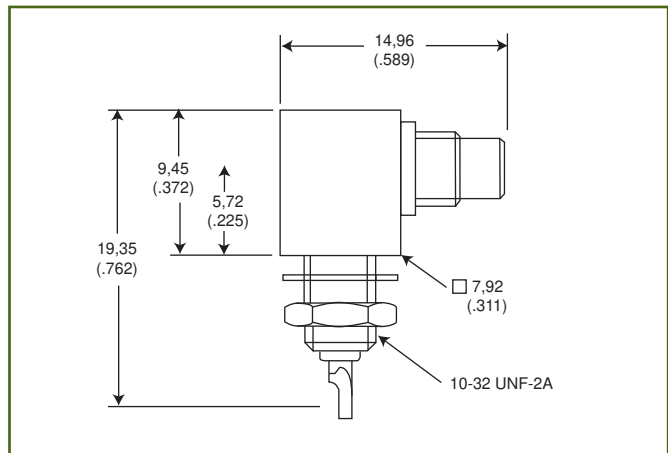

Mounting Plan V (Page 40)

Dimensions shown in mm (inch)
Specifications and dimensions subject to change

PRINTED CIRCUIT BOARD JACKS

SMC PCB preferred styles feature stepped legs. This allows the jacks to be raised from the surface of the PCB, thereby preventing the accumulation of soldering fluids and foreign bodies. A single piece conductor overcomes the problem of internal joint separation during continuous wave/flow soldering operations.

Straight PCB Jack, 1,00 (.039) square legs

Part Number
B50 - 051 - 0000220

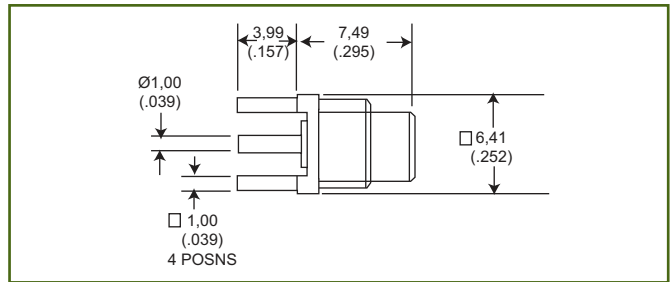

Mounting Plan A (Page 40)

Straight PCB Jack, 0,81 (.032) square legs

Part Number
B50 - 051 - 9019220

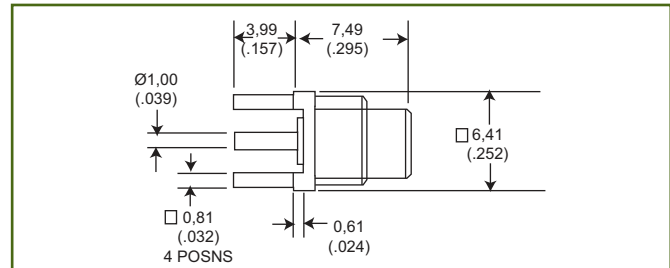

Mounting Plan B (Page 40)

Right Angle PCB Jack, 1,00 (.039) square legs

Part Number
B50 - 053 - 0000220

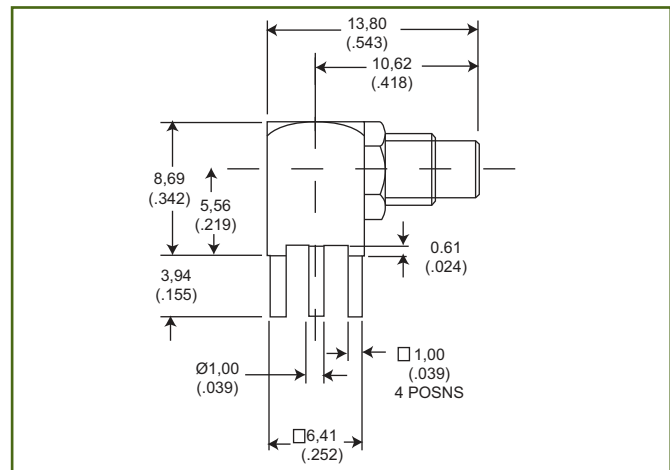

Mounting Plan A (Page 40)

Right Angle PCB Jack, 0,81 (.032) sq Legs

Part Number
B50 - 053 - 9019220

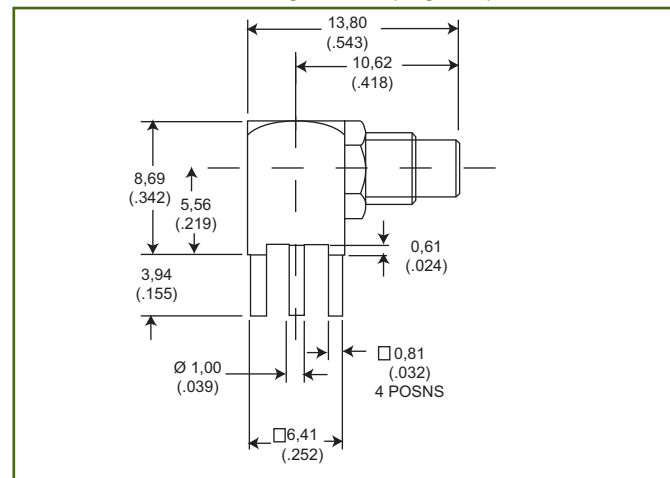

Mounting Plan B (Page 40)



This range of 50 ohm microminiature radio frequency connectors is suitable for both military and commercial equipment operating at frequencies up to 4 GHz (SSMB) and 12.4 GHz (SSMC). They provide a choice of Snap-on (SSMB) or Screw-on (SSMC) and are available for a wide range of flexible cables.



SSMC connectors are used where a positive mechanical engagement is required and where space permits the use of torque wrenches. SSMB connectors are quick disconnect versions of the SSMC and are used in applications where limited space prohibits the use of torque wrenches or when components or modules must be quickly changed to keep down time to a minimum.

Key Features

- Small size
- Low mass
- Close packing density
- Used in airborne applications

MATING INTERFACE

SSMB (SNAP-ON)

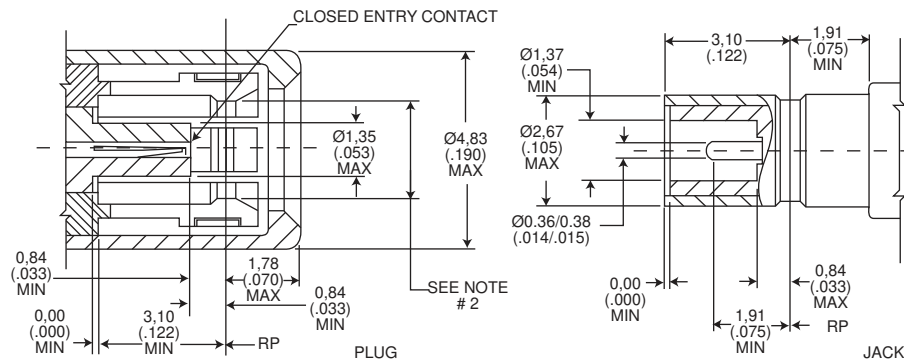

SSMC (SCREW-ON)

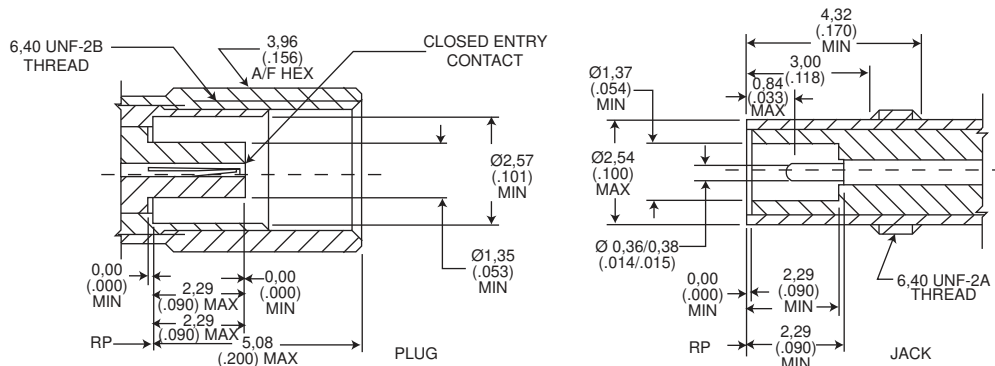

NOTES

1) Inside diameter of female contact to meet VSWR, mating characteristics and connector durability, when mated with a 0,36 - 0,38 (.014 - .015) diameter male contact.

2) Must meet the force to engage and disengage when mated with its mating part.

Dimensions shown in mm (inch)
 Specifications and dimensions subject to change

www.ittcannon.com



SPECIFICATIONS

ELECTRICAL	Impedance	50Ω				
	Frequency Range	SSMB = 0 to 4.0 GHz. SSMC = 0 to 12.4 GHz				
	Voltage Rating	At Sea Level = 250 Vrms. at 21km (70k feet) = 60 Vrms				
	Insulation Resistance	1000 MΩ minimum				
	Contact resistance	Center Contact = 4.0 m Ω maximum initial. 6.0 m Ω maximum after environment Outer Contact = 1.0 m Ω maximum initial. 1.5 m Ω maximum after environment Braid to Body = 1.0 m Ω maximum				
	Contact Current Rating	1.0 A dc maximum				
	Insertion Loss	0.30 dB maximum @ 1.5 GHz				
	RF Leakage	SSMB = -40 dB minimum @ 2 - 3 GHz SSMC = -50 dB minimum @ 2 - 3 GHz				
	Voltage Standing Wave Ratio (VSWR) To 12.4 GHz or 80% of upper cut-off frequency of the cable, whichever is lower. Applicable to 50Ω cables only.(F= GHz)	Connector Configuration				
		SSMB		SSMC		
	Cable group	Straight	Right Angle	Straight	Right Angle	
	RG178/U, 196/U	1.25 + .02F	1.25 + .03F	1.20 + .02F	1.20 + .03F	
	RG188/U, 316/U	1.30 + .02F	1.30 + .03F	1.25 + .03F	1.30 + .02F	
MECHANICAL	Engagement Forces	SSMB: Initial = 26.7 N (6 lbs.) max. engagement and 8.9 N(2 lbs.) minimum disengagement. After 500 matings = 26.7 N (6 lbs.) max. engagement and 4.4 N (1 lb.) min. disengagement. SSMC: 0.11 Nm (16 in. oz.) torque max.				
	Mating Torque	SSMB: N/A SSMC: 0.2 Nm to 0.23 Nm (28 - 32 in.oz)				
	Locknut Torque	0.28 Nm to 0.35 Nm (40 - 50 in. oz)				
	Coupling Nut Retention	SSMB: N/A SSMC: 111 N (25 lbs.) minimum				
	Materials	Body, Body Components: Brass, half hard. Male and Female Contacts: Beryllium Copper. Insulators: PTFE Lockwashers: Phosphor Bronze. Crimp Ferrule: Annealed copper alloy.				
ENVIRONMENTAL	Finish/Plating	Center Contacts: Gold plated. Other Metal Parts: Gold or nickel plated to meet the finish and corrosion requirements of MIL-C-39012				
	Temperature Rating	-65° C to 165° C				
	Corrosion (salt spray)	MIL-STD-202, Method 101, test condition B, 5% salt solution				
	Vibration, High Frequency	MIL-STD-202, Method 204, SSMB: test condition B (15 G's). SSMC: test condition D (20 G's)				
	Shock	MIL-STD-202, Method 213, SSMB: test condition B, 75 G's @ 6 milliseconds, 1/2 sine. SSMC: test condition C, 100 G's @ 6 milliseconds, 1/2 sine.				
GENERAL	Thermal Shock	MIL-STD-202, Method 107, test condition B, except high temperature shall be 85° C. High temperature shall be 200°C for connectors using 200°C cables.				
	Connector Durability	500 matings minimum				
	Contact Captivation	8,9 N (2 lbs.) minimum axial force.				
	Cable Retention	When properly assembled to the compatible single braided coaxial cable, the retention is equal to the breaking strength of the cable.				

Body plating options

The following part number suffices can be specified for SSMB and SSMC connectors.

...220 gold body

...910 nickel body

PLUGS, JACKS AND RECEPTACLES

Straight Plug

Part Number	Cable Numbers	A
051 - 424 - 3188220	RG174/U, 316/U	20,01 (.790)
A51 - 424 - 3196220	RG178/U, 196/U	19,33 (.761)

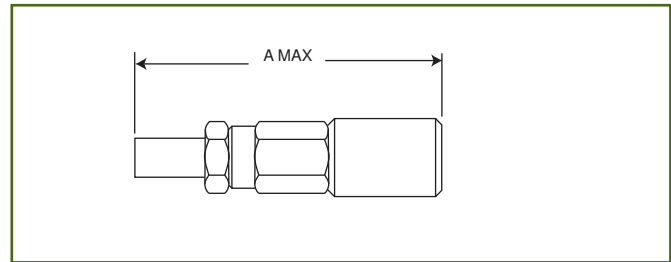

Assembly Instructions

- 051 - 424 - 3188220 AI 663 (Page 44)
- A51 - 424 - 3196220 AI 128 (Page 44)

Right Angle Plug

Part Number	Cable Numbers	A
A51 - 428 - 3188220	RG174/U, 316/U	9,55 (.376)
A51 - 428 - 3196220	RG178/U, 196/U	9,55 (.376)
A51 - 428 - 3875220	FD316	10,16 (.400)

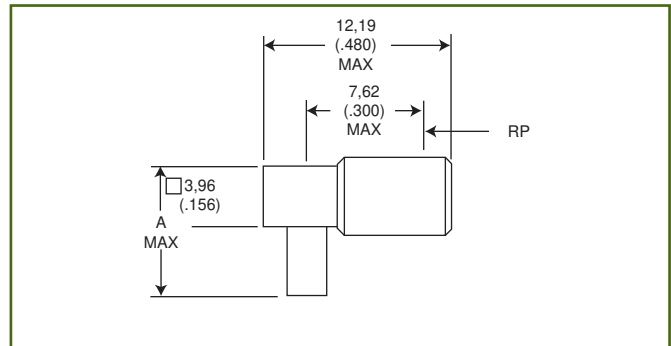

Assembly Instructions

- A51 - 428 - 3188220 AI 129 (Page 45)
- A51 - 428 - 3196220 AI 696 (Page 45)
- A51 - 428 - 3875220 AI 696 (Page 45)

Bulkhead Jack

Part Number	Cable Numbers	A
051 - 427 - 3188220	RG174/U, 316/U	9,93 (.391)
A51 - 427 - 3196220	RG178/U, 196/U	10,41 (.410)

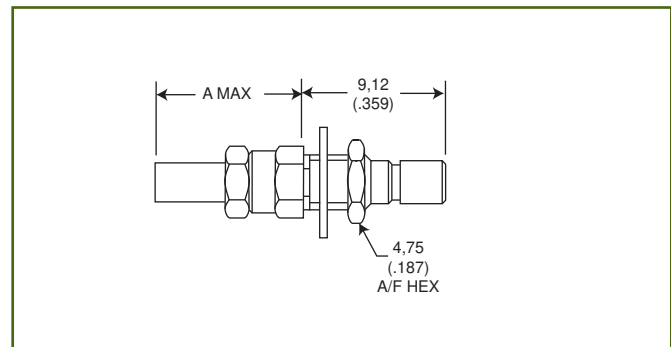

Mounting Plan U (Page 40)

Assembly Instructions AI-128 (Page 44)

Bulkhead Receptacle - Rear Mount
Mounting Nut Outside Panel

Part Number
051 - 443 - 0000220

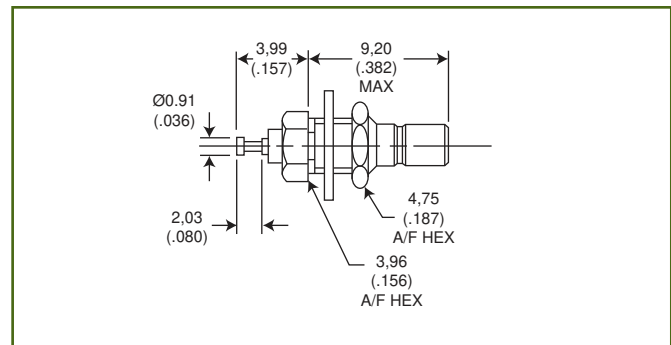

Mounting Plan U (Page 40)



BULKHEAD AND PRINTED CIRCUIT RECEPTACLES

Bulkhead Receptacle - Front Mount
Mount Nut Inside Panel

Part Number
051 - 445 - 0000220

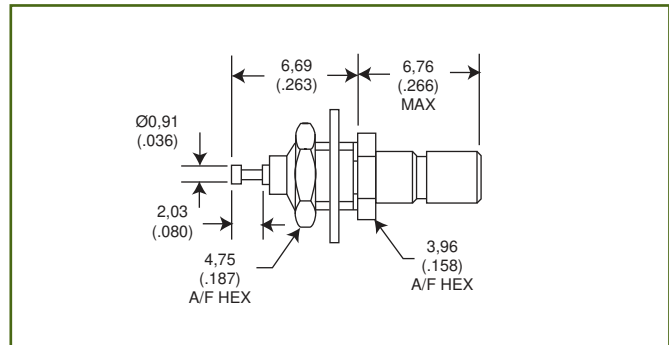

Mounting Plan U (Page 40)

Printed Circuit Receptacle - Straight Jack

Part Number
A51 - 451 - 0000220

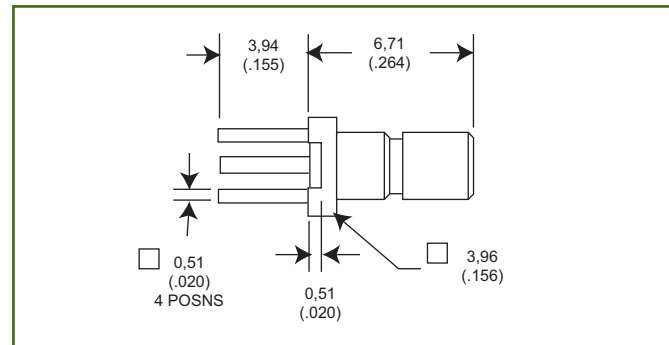

Mounting Plan C (Page 40)

Printed Circuit Receptacle - Straight Plug

Part Number
051 - 452 - 0000220

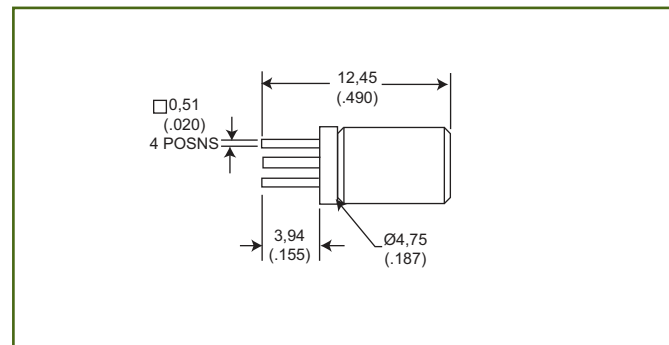

Mounting Plan C (Page 40)

Printed Circuit Receptacle - Right Angle Jack

Part Number
A51 - 453 - 0000220

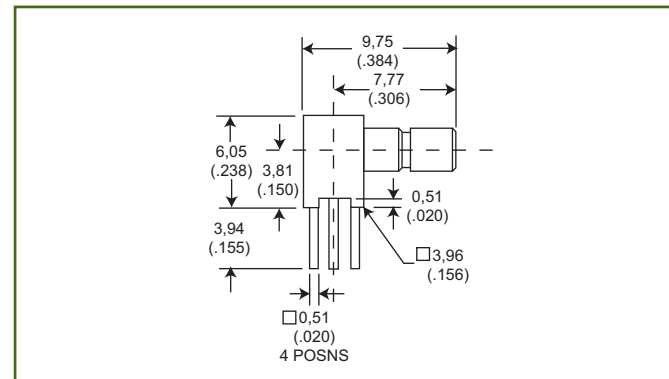

Mounting Plan C (Page 40)



PLUGS AND RECEPTACLES

Straight Plug

Part Number	Cable Numbers
050 - 424 - 3188220	RG174/U, 316/U
050 - 424 - 3196220	RG178/U, 196/U

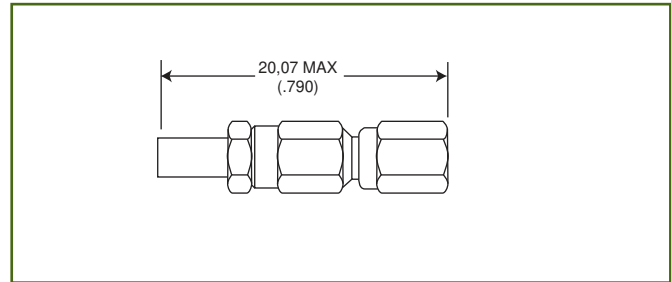

Assembly Instructions

- 050 - 424 - 3188220 AI 663 (Page 44)
- 050 - 424 - 3196220 AI 128 (Page 44)

Right Angle Plug

Part Number	Cable Numbers	A
050 - 428 - 3188220	RG174/U, 316/U	10,16 (.400)
050 - 428 - 3196220	RG178/U, 196/U	9,40 (.370)

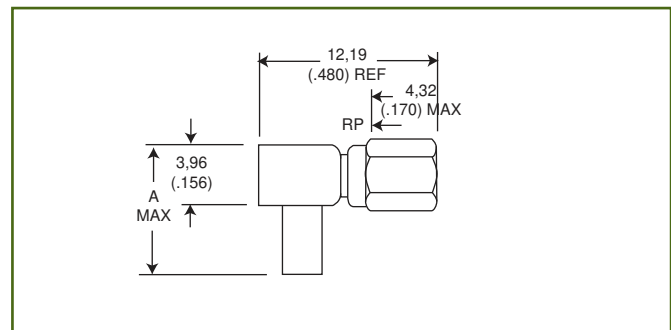

Assembly Instructions

- 050 - 428 - 3188220 AI 286 (Page 45)
- 050 - 428 - 3196220 AI 696 (Page 45)

Bulkhead Receptacle - Rear Mount
Mounting Nut Outside Panel

Part Number
050 - 443 - 0000220

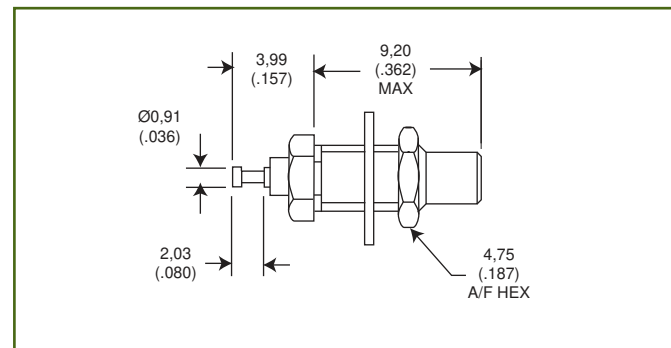

Mounting Plan U (Page 40)

Bulkhead Receptacle - Front Mount
Mounting Nut Inside Panel

Part Number
050 - 445 - 0000220

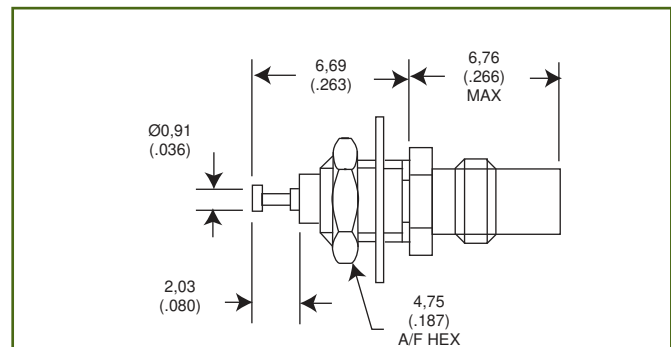

Mounting Plan U (Page 40)

Dimensions shown in mm (inch)
Specifications and dimensions subject to change
www.ittcannon.com



PRINTED CIRCUIT RECEPTACLES

Printed Circuit Receptacle - Straight Jack

Part Number
050 - 451 - 0000220

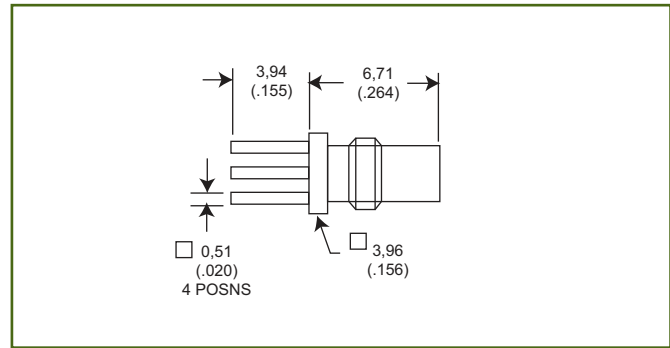

Mounting Plan C (Page 40)

Printed Circuit Receptacle, Right Angle Jack

Part Number
050 - 453 - 0000220

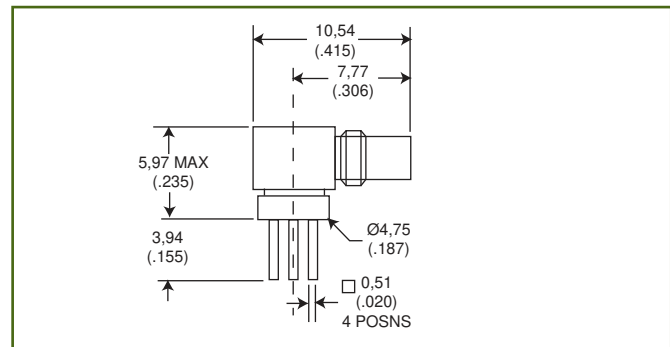

Mounting Plan C (Page 40)

Cannon's Coaxial Terminators provide a low cost means of joining cable to a printed circuit where engagement and disengagement are not required. This method of terminating cable on PCBs eliminates the inconsistency associated with hard wiring.

Styles are available for a variety of popular RG series cable types and cables of similar dimensions. The tapered leg is an interference fit into the PCB hole enabling pre-assembly for wave soldering.

All parts have electro-plated tin finish.



Coaxial Terminators feature:

- Low cost
- Easy to assemble
- Only two piece parts
- Surface mount option
- No solder transfer down braid
- Good stability ± two point fixing
- Variable pitch, 2,50 (.098) ± 10,00 (.393)

TERMINATORS

Single Leg

Part Number	Cable Numbers
055 - 939 - 9019AR6	RG178/U, 196/U
055 - 939 - 9029AR6	RG174/U, 179/U, 188/U, 316/U

NOTE

Both part numbers may be assembled with leg either at front or rear.

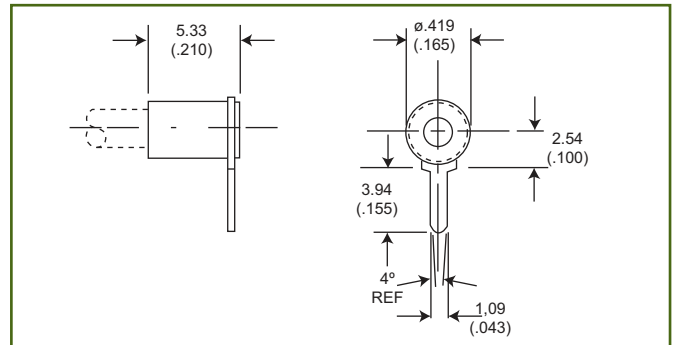

Assembled with leg at front. Mounting Plan R (Page 40)

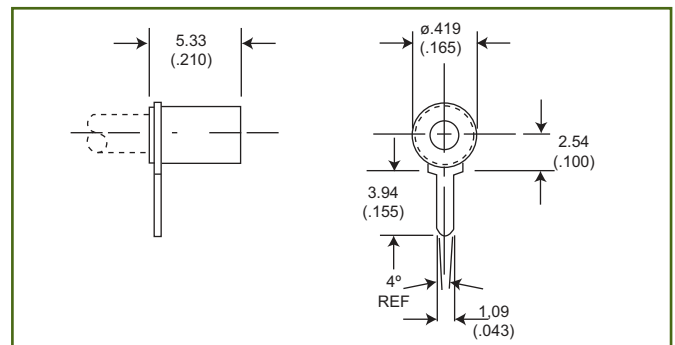

Assembled with leg at rear. Mounting Plan S (Page 40)

Assembly Instructions
BBAI-1203 (Page 53)

Dimensions shown in mm (inch)
Specifications and dimensions subject to change



TERMINATORS

Two Legs at Front, Standard

Part Number	Cable Numbers
055 - 939 - 9039AR6	RG178/U, 196/U
055 - 939 - 9049AR6	RG174/U, 179/U, 188/U, 316/U

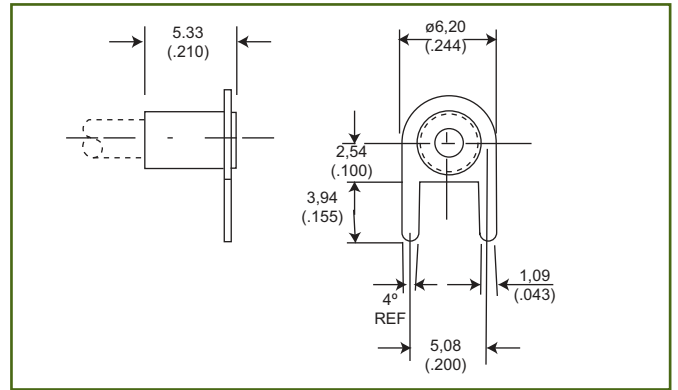

Mounting Plan T (Page 40)
 Assembly Instruction BBAI-1203 (Page 53)

Two Legs at Front, Surface and Vertical Mount

Part Number	Cable Numbers
055 - 939 - 9059AR6	RG178/U, 196/U
055 - 939 - 9069AR6	RG174/U, 179/U, 188/U, 316/U

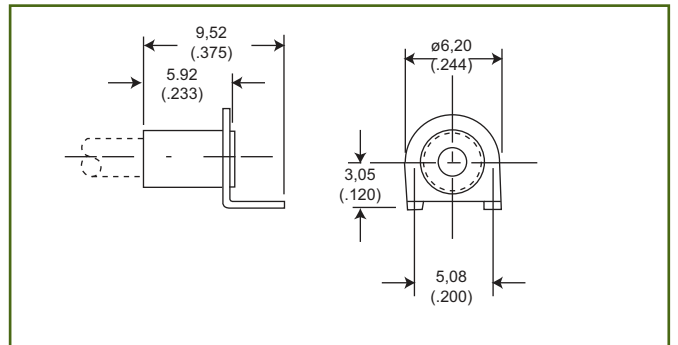

Mounting Plan T (Page 40)
 Assembly Instruction BBAI-1203 (Page 53)

Between Series Adaptors are widely used for high efficiency transitions between various types of FF coaxial connectors. They are used for connecting test equipment to systems employing a different type connector or they are used as a component in electronic equipment where it is desirable to have one type of connector for external connections and another type for internal connections.

All Between Series Adaptors are designed for lowest VSWR characteristics up to the frequency limits of the connector types involved. All popular types of miniature, subminiature and micro-miniature designs are available.

The designs shown here are not the entire range. If you require a style not shown, please contact our Customer Service group.



Key Features

- Rugged construction
- Precision performance
- Low VSWR
- Ready to use - no assembly required

SMA Jack to SMC Plug

Part Number
050 - 074 - 6201310

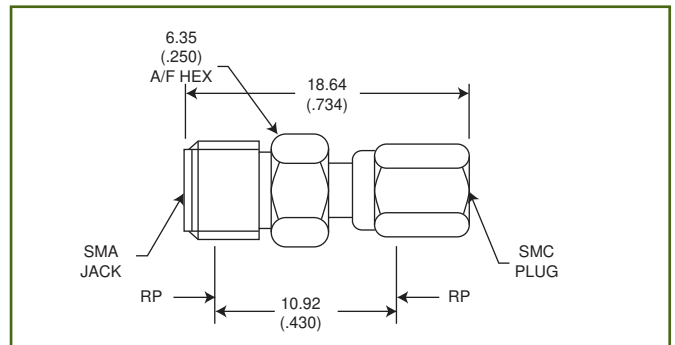

SMA Jack to SMB Plug

Part Number
050 - 674 - 6302310

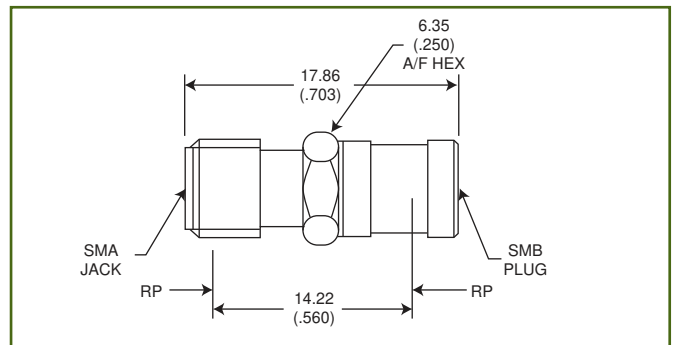

Dimensions shown in mm (inch)
 Specifications and dimensions subject to change

SMA Side-On Plug to SMA Standard Jack
Adaptor - Straight (Connector Saver)

Part Number
050 - 674 - 6324990

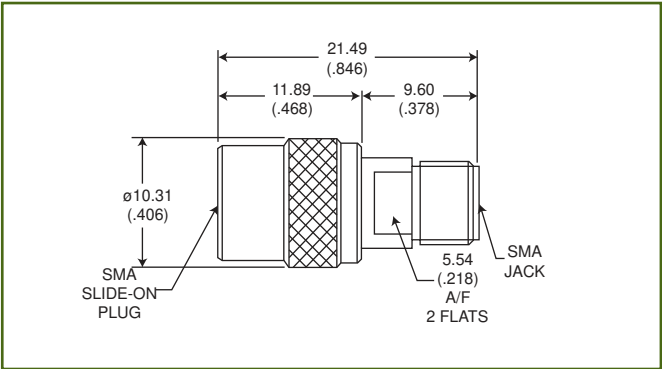

BNC Bulkhead Jack to SMA Jack

Part Number
050 - 675 - 6801890

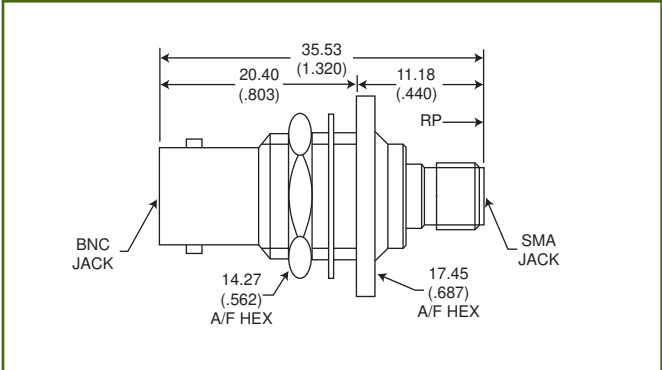

Mounting Plan Z (Page 40) Panel Thickness 3,18 (.125) max.

N Plug to SMA Jack

Part Number
050 - 674 - 6700890

VSWR:

1.10 + .01f (GHz) DC - 12.4GHz

1.10 + .016f (GHz) 12.4 - 18 GHz

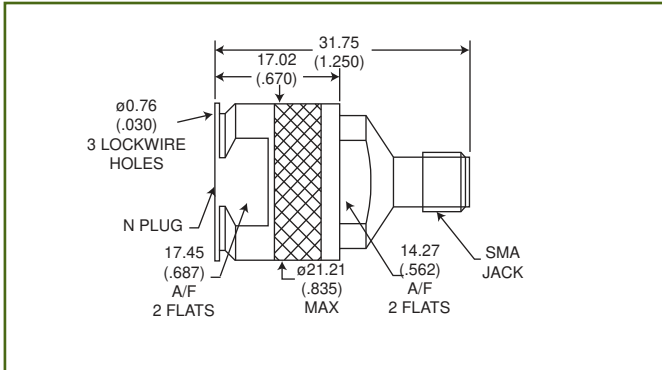

N Bulkhead Jack to SMA Jack

Part Number
050 - 675 - 6705890

VSWR:

1.06 + .005f (GHz) DC - 12.4GHz

1.06 + .010f (GHz) 12.4 - 18 GHz

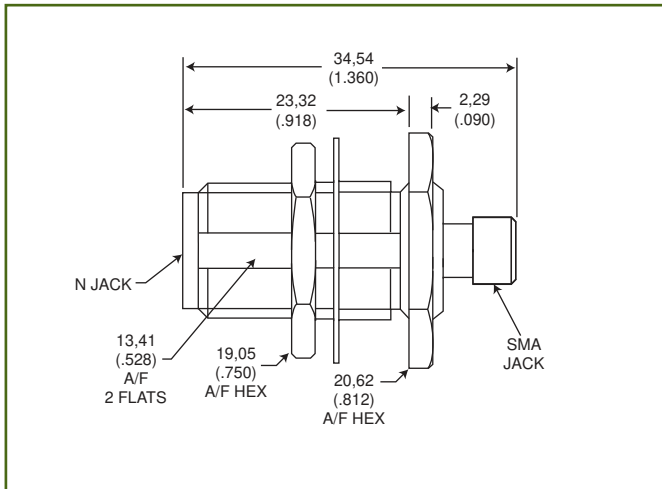

Mounting Plan GG (Page 40)
Panel Thickness 6,35 (.250) max.



Dimensions shown in mm (inch)
Specifications and dimensions subject to change

Sealflex 2 microwave cable assemblies are designed for applications requiring consistent microwave performance through to 18 GHz and may be used with minimal degradation to 26 GHz with SMA connectors.

All connector designs exhibit “mode free” characteristics to 18 GHz, thereby allowing low VSWR to be specified without “spikes” being present in the upper frequency spectrum.

Each assembly is 100% tested for VSWR and insertion loss and test plots are supplied with each item.

Sealflex 2 assemblies have been adopted for use in various avionic systems, missiles, military ground and shipborne applications as well as commercial communications equipment.



Key Features

- Fully flexible cable
 - Does not require detailed drawing (unlike semi-rigid)
- Triple screens (90 dB RF shielding)
- DC to 26 GHz frequency range
- 100% electrically tested
 - VSWR and insertion loss plots supplied

SPECIFICATIONS

ELECTRICAL		Impedance	50Ω nominal		
		Voltage Standing Wave Ratio (VSWR)	1.25 (2 - 12.4 GHz) 1.35 (12.4 - 18 GHz)		
		Attenuation	See graph on next page		
		Shielding RF	-90 dB		
MECHANICAL		Connector Retention	137 N (30.9 lbs) minimum		
		Connector / Cable Torque	1.7 Nm (15 in. lbs) minimum		
		Minimum Bend Radii	Cable Diameter	Static	Flexing
			3,18 (.125)	13,00 (.511)	25,00 (.984)
			4,57 (.180)	19,00 (.748)	38,00 (1.496)
			6,35 (.250)	25,00 (.984)	51,00 (2.007)
ENVIRONMENTAL		Operating Temperature	-65° C to 165° C		
		Moisture Resistance	MIL-STD-202, Method 106		
		Vibration	MIL-STD-202, Method 204(C)		
		Shock	MIL-E-5272, Para. 4.15.5.1		
		Thermal Shock	MIL-STD-202, Method 107(C)		
		Corrosion	MIL-STD-202, Method 101(B)		
		Solvent Resistance	7 days at 200° C, JP6 (MIL-J-2658) and hydraulic fluid (MIL-H-5806)		

NOTES: Tighter specifications are subject to special quotation.

Dimensions shown in mm (inch)
Specifications and dimensions subject to change

Attenuation

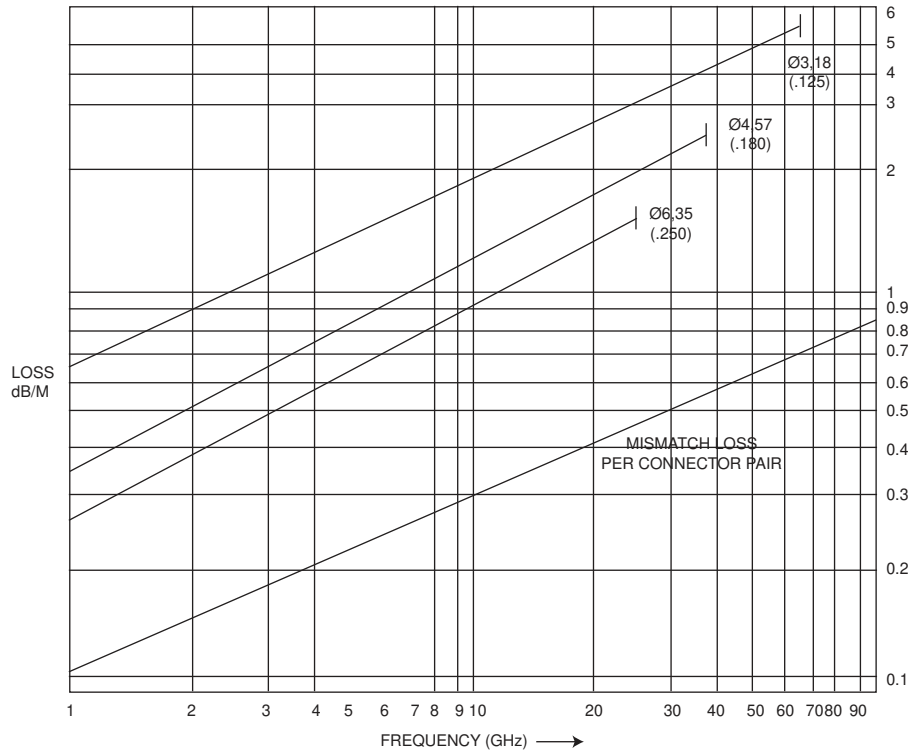

Cable Maximum Frequency (f_c): Ø 3,18 (.125) = 65.3 GHz
 (single mode operation) Ø 4,57 (.180) = 36.8 GHz
 Ø 6,35 (.250) = 23.7 GHz

Typical Return Loss (VSWR) Part Number 065-9AA-1000000

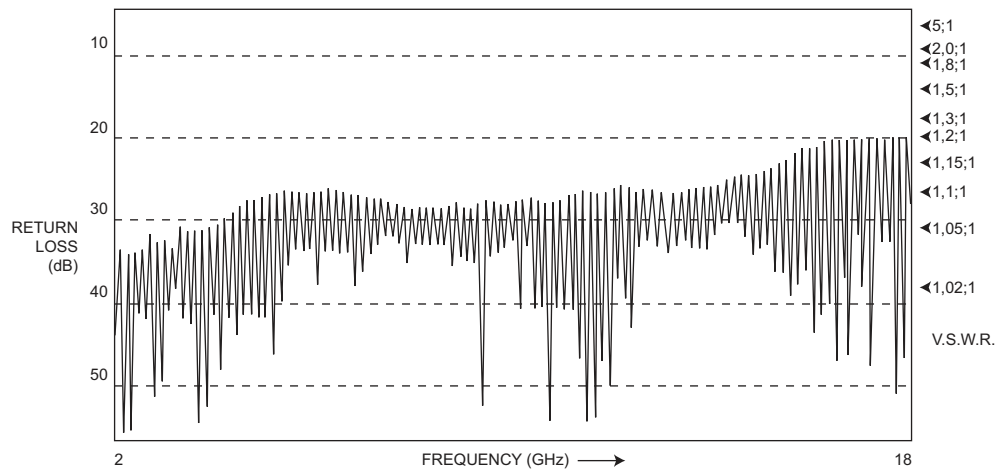

MICROWAVE CABLE ASSEMBLIES

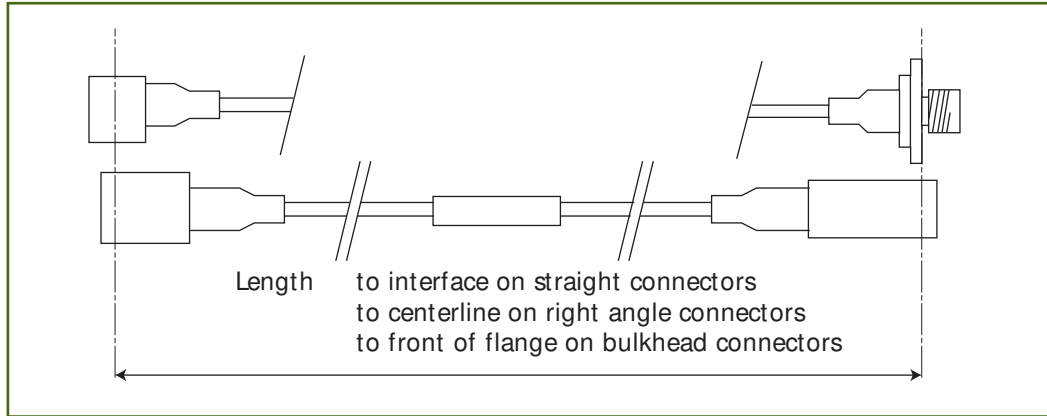

Standard Tolerances	Length up to 1 m (39.370)	-0 + 10,00 (.393)
	1 m (39.370) to 3 m (118.00)	-0 + 20,00 (.787)
	3 m (118.00) to 15 m (1771.65)	-0 + 30,00 (1.181)

ORDERING INFORMATION

This table shows how the part numbers for coaxial connectors are constructed.

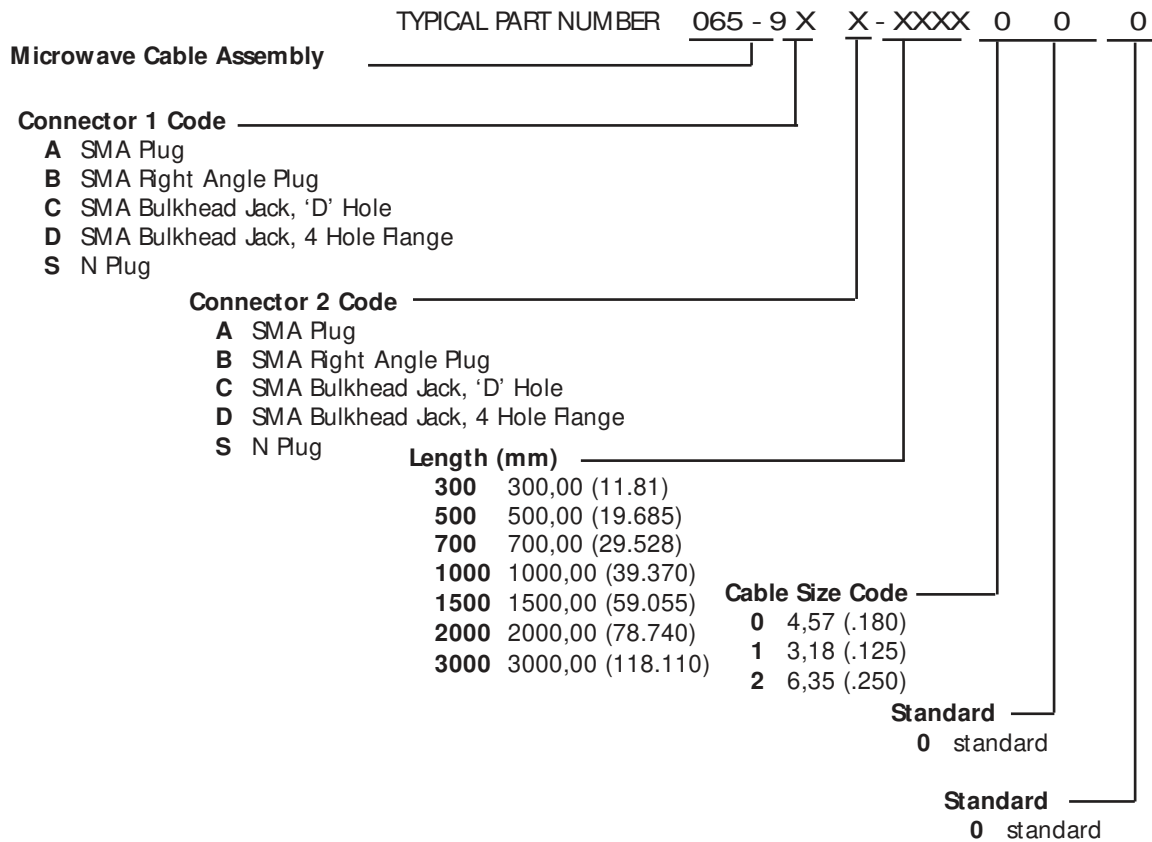

Example: 065-9AS-1000000 = Sealflex 2 cable assembly; 4,57 (.180) with 1 SMA plug and 1 N plug on 1 metre length of cable

Dimensions shown in mm (inch)
 Specifications and dimensions subject to change



RECOMMENDED MOUNTING HOLE DIMENSIONS

Plan	A	B (min.) 4 positions	C (min.) 1 position
A	5,08 (.200)	ø 1,70/1,85 (.067/.080)	ø 1,17/1,35 (.046/.053)
B	5,08 (.200)	ø 1,30 (.051)	ø 1,30 (.051)
C	2,54 (.100)	ø 0,97 (.038)	ø 0,91 (.036)
D	5,08 (.200)	ø 1,70 (.067)	ø 1,70 (.067)

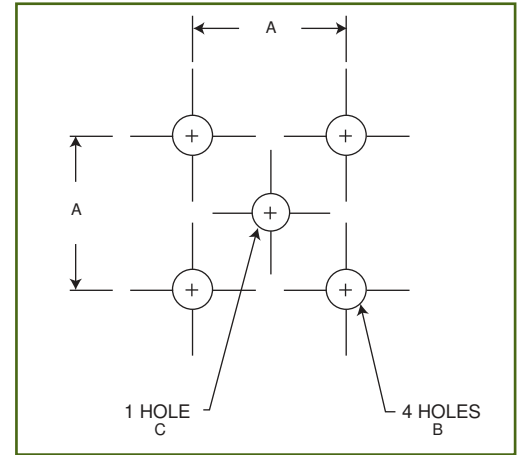

Plan A - D

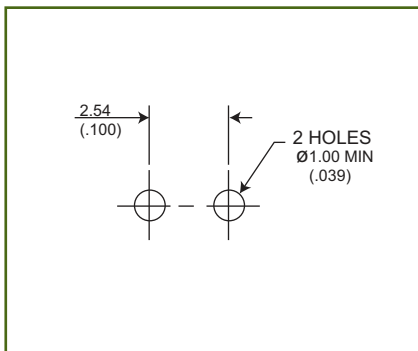

Plan R

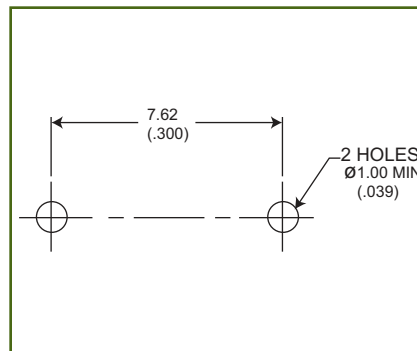

Plan S

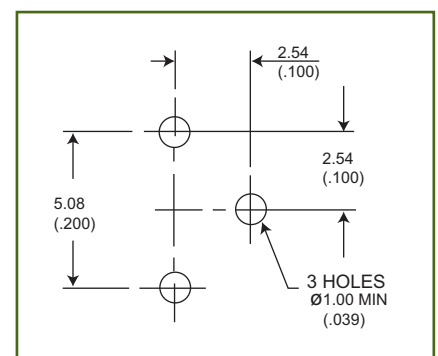

Plan T

Plan	Thread Size	A +0,13 (.005) -0,00 (.000)	B +0,13 (.005) -0,00 (.000)
U	6-40 UNF-2A	3,56 (.140)	3,20 (.126)
V	10-32 UNF-2A	4,95 (.195)	4,50 (.177)
W	1/4-36 UNS-2A	6,73 (.265)	5,92 (.233)
Z	1/2-28 UNEF-2A	13,08 (.515)	12,19 (.480)

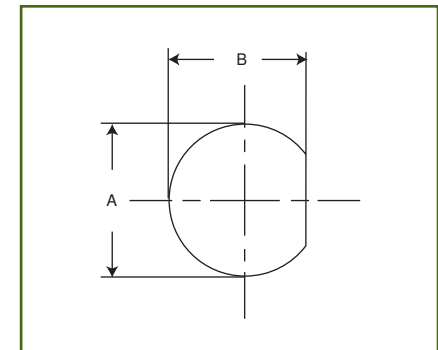

Plan U - Z

Plan	Thread Size	A +0,10 (.004) -0,03 (.001)	B +0,10 (.004) -0,03 (.001)
GG	5/8-24 UNEF-2A	15.9 (.625)	13.5 (.531)

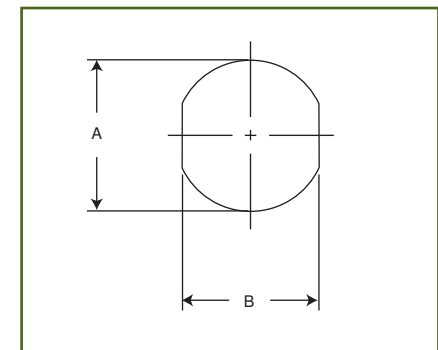

Plan GG



Dimensions shown in mm (inch)
Specifications and dimensions subject to change

www.ittcannon.com

AI-90 SMA Right Angle Connectors, Crimp Type for Braided Cable

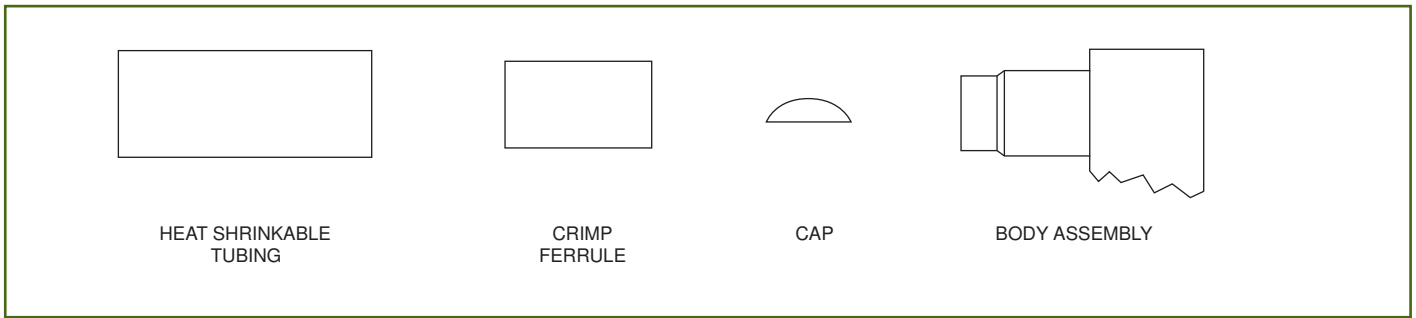

STEP 1 - 2

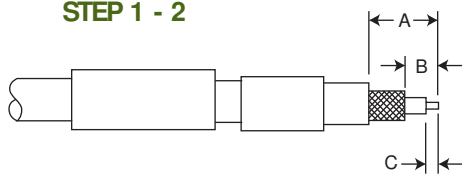

1. Slide ferrule and (if supplied) heat shrinkable tubing on to cable.
2. Trim cable to dimensions shown:

Assembly Instruction No.	A	B	C
AI-90	11,10 (.437)	5,16 (.203)	1,57 (.062)

STEP 4

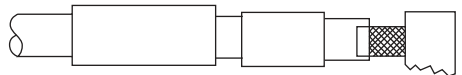

3. Tin center conductor (DO NOT OVER TIN).

STEP 5

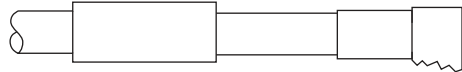

4. Slide body over cable dielectric and under the braid until braid is flush against underside of body. Ensure center conductor is located in the forked end of the contact. NOTE: When using cables with inflexible jackets it is permissible to make two 3,17 (.125) longitudinal slits in the outer jacket.

STEP 6

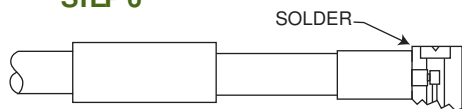

5. Side ferrule flush against the body and crimp in position using Cannon's Crimp Tool and suitable Die Set (see table).
6. Using a small soldering iron solder center conductor to contact. NOTE: The center conductor should not protrude beyond the contact or touch the body. Solder should not protrude beyond the slotted section of the contact.

STEP 7

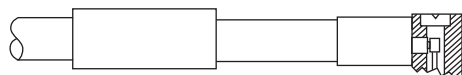

7. Locate the cap in rear of body and dimple or lightly punch to ensure it is locked in position.

STEP 8

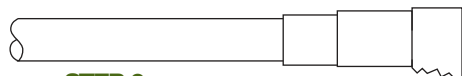

8. Slide heat shrinkable tubing over ferrule flush against body and heat until tubing shrinks down.

Only common cable retention features are shown in detail. Various body configurations can apply.

Cable Numbers	Cable Code	Die Size	Die Set
RG142/U	9142	5,42 (.213)	K29265
RG196/U	9196	2,67 (.105)	K29263
RG316/U	9188	3,25 (.128)	K29263
RD316	9399/9875	3,84 (.151)	T1025/9

Dimensions shown in mm (inch)
Specifications and dimensions subject to change

AI-98 SMA Right Angle Connectors, Direct Solder Type for Semi-Rigid Cable



STEP 1



1. Trim cable jacket, dielectric and center conductor to dimensions shown, being careful not to fracture the center conductor. Tin center conductor (DO NOT OVERTIN).

$$A = 4,75 \pm 0,13 \text{ (.187} \pm .005\text{)}$$

$$B = 2,29 \pm 0,13 \text{ (.097} \pm .005\text{)}$$

STEP 2

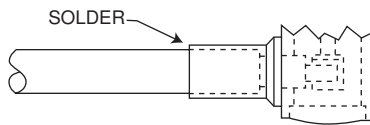

2. Slide cable into body and solder into place.

STEP 3

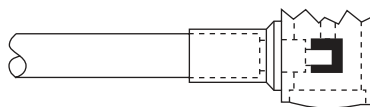

3. Solder center conductor to contact (do not over solder), then locate the cap in rear of body and dimple or lightly punch to ensure it is locked in position.

AI-102 & AI-236 SMA Straight Connectors, Crimp Type for Braided Cable

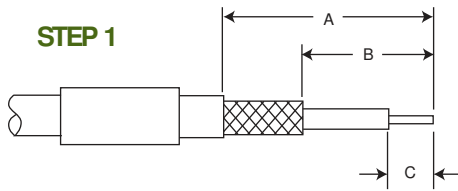
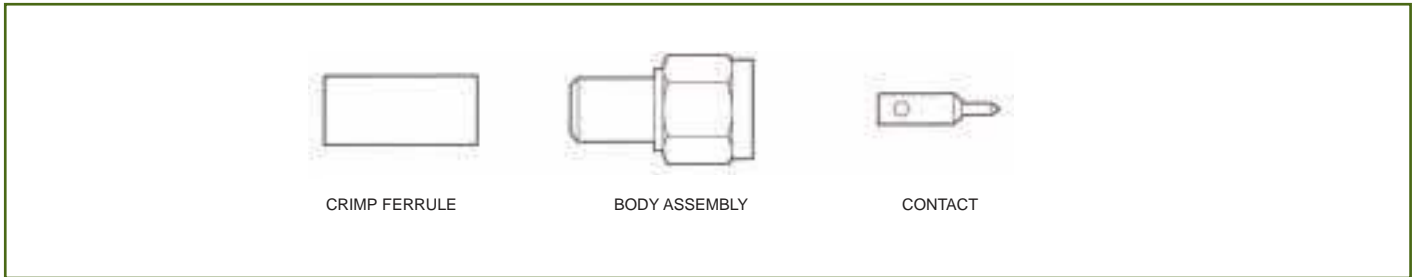

1. Trim cable to dimensions shown being careful not to nick the braid or center conductor. Tin center conductor, (DO NOT OVERTIN) then slip ferrule (and shrink tubing if supplied) over cable.

Assembly Instruction No.	A	B	C
AI-102 & AI-236	10,31 (.406)	4,37 (.172)	2,77 (.109)

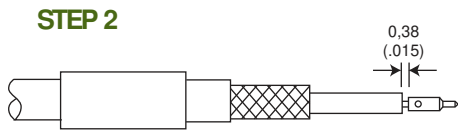

2. Solder center conductor to contact. With AI-102 and AI-236 the gap shown is to be maintained.

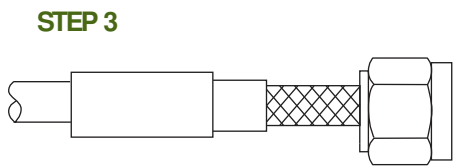

3. Insert trimmed cable into the rear of the body assembly. Tubular body extension will slide under the braid with the rear portion of extension fitting under the jacket as shown. NOTE: When using cables with inflexible jackets it is permissible to make two 3,17 (.125) long longitudinal slits in the outer jacket.

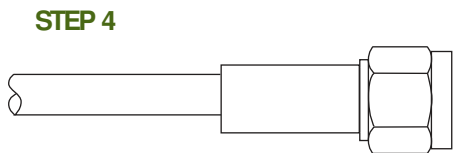

4. Slide ferrule flush against the body and crimp in position using Cannon's Crimp Tool and suitable Die Set (see table).

Cable Numbers	Cable Code	Die Size	Die Set
RG141/U	9141	5,42 (.213)	K29265
RG142/U	9142	5,42 (.213)	K29265
RG188/U	9188	3,25 (.128)	K29263
RG196/U	9196	2,67 (.105)	K29263
RD316	9399/9875	3,84 (.151)	T1025/9

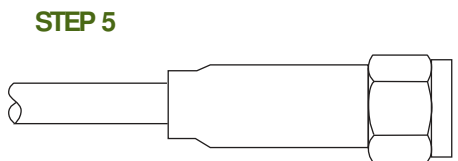

5. Slide heat shrinkable tubing over ferrule and apply heat until tubing shrinks down.

Dimensions shown in mm (inch)
 Specifications and dimensions subject to change

www.ittcannon.com



AI-128 & AI-663

SSMB / SSMC Straight Connectors, Crimp Type for Braided Cable

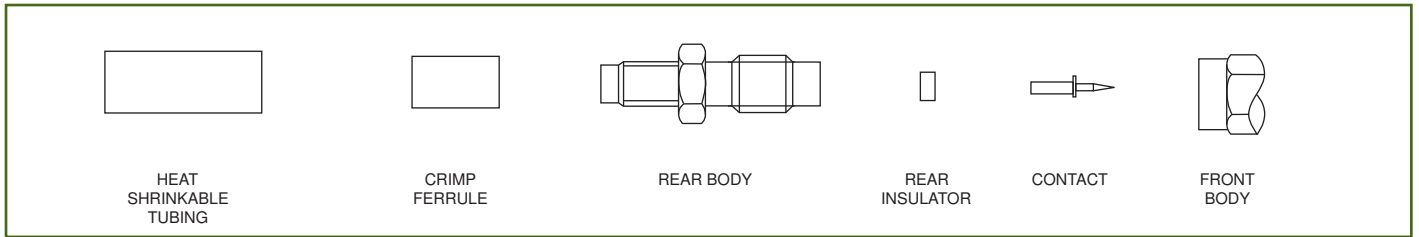

STEP 1



1. Slide heat shrinkable tubing and ferrule on to cable.

STEP 2

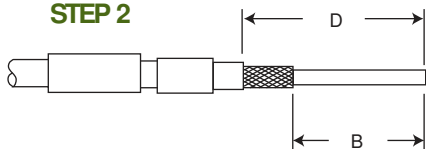

2. Trim cable to dimensions shown:

Assembly Instruction No.	B	C	D
AI-663	6,86 (.270)	2,29 (.090)	10,41 (.410)
AI-128 for center conductors \varnothing 0.51 (.020)	6,76 (.266)	2,29 (.090)	9,53 (.375)
AI-128 for all other conductor sizes	7,54 (.297)	3,05 (.120)	10,31 (.406)

STEP 3

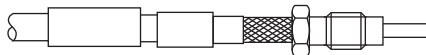

3. Slide rear body over dielectric and under the braid until braid is flush with flange. N.B. When using cable with inflexible jackets it is permissible to make two 3,00 (.118) long longitudinal slits in the outer jacket.

STEP 4

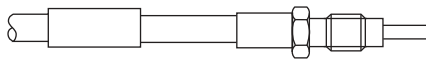

4. Slide ferrule over exposed braid up to hex. flange.
5. Crimp using Cannon's Crimp Tool and suitable Die Set (see table). Ensure ferrule is held close to hex. flange.

STEP 7



6. Slide heat shrinkable tubing over crimp and heat shrink into place using hot air gun. Air temperature should be approximately 125° C.

STEP 8

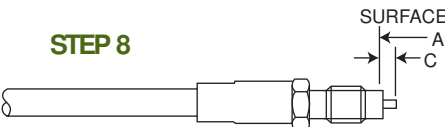

7. Trim dielectric flush with surface "A" on body using a sharp knife. Take care not to nick center conductor.

STEP 12

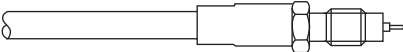

8. Trim center conductor as shown.
9. Tin center conductor (do not allow solder to touch end of body or dielectric).
10. Place a small solder preform made from 0,26 - 0,31 (.010 - .012) dia. (28 swg) multi-core solder in rear of contact.

STEP 14



11. Place rear insulator over center conductor. When insulator has counterbore, the contact fits into the counterbore.
12. Assemble contact onto center conductor, heat to make solder connection. Do not allow solder to protrude outside spill hole.
13. Solder should be visible at inspection hole, if excess solder runs from inspection hole, remove with sharp blade taking care not to damage plating.
14. Screw on the front body and tighten to a torque of 0.14Nm (20 in. ozs)

Only common cable retention features are shown in detail. Various body configurations can apply.

Cable Numbers	Cable Code	Die Size	Die Set
RG196/U	3196	2,67 (.105)	K29263
RG316/U	3188	3,25 (.128)	K29263
RD316	3875	3,84 (.151)	T1025/9

AI-129, AI-286 & AI-696 SSMB / SSM C Right Angle Connectors, Crimp Type for Braided Cable

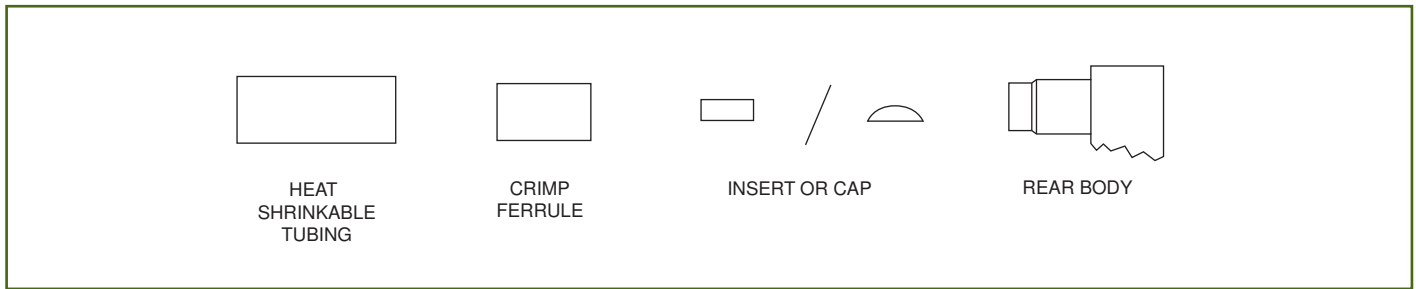

1. Slide heat shrinkable tubing and ferrule on to cable.
2. Trim cable to dimensions shown:

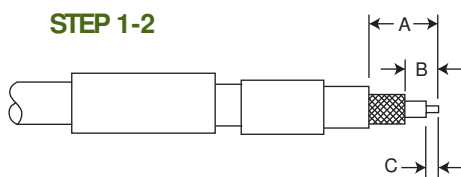

Assembly Instruction No.	A	B	C
AI-129	5,56 (.219)	2,77 (.109)	1,19 (.047)
AI-286	6,35 (.250)	2,77 (.109)	0,79 (.031)
AI-696	6,22 (.245)	2,54 (.100)	1,14 (.045)

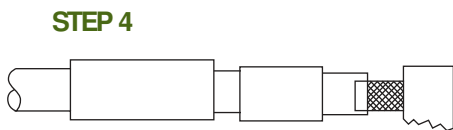

3. Tin center conductor. (DO NOT OVERTIN).
4. Slide body over cable dielectric and under the braid until braid is flush against underside of rear body. Ensure center conductor is located in the forked end of the contact. NOTE: When using cables with inflexible jackets it is permissible to make two 3,00 (.118) longitudinal slits in the outer jacket.

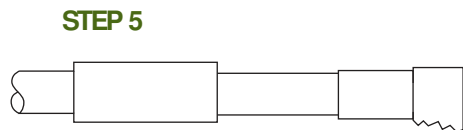

5. Slide ferrule flush against the body and crimp in position using Cannon's Crimp Tool and suitable Die Set (see table).
6. Using a small soldering iron solder center conduct to contact. NOTE: The center conductor should not protrude beyond the contact or touch the body. Solder should not protrude beyond the slotted section of the contact.

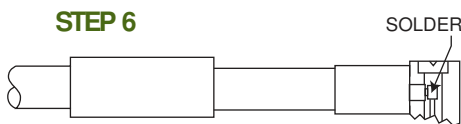

7. Press insert into place or locate the cap in rear of body and dimple or lightly punch to ensure it is locked into position (recommended tool, flat pin \varnothing 3,07 +/- 0,05) (.121 +/- .002).

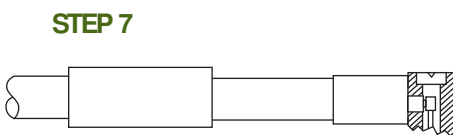

8. Slide heat shrinkable tubing over ferrule flush against body and heat until tubing shrinks down.

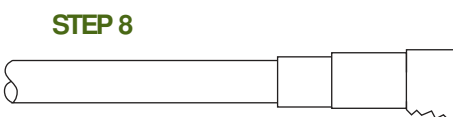

Cable Numbers	Cable Code	Die Size	Die Set
FG196/U	3196	2,67 (.105)	T1025/1
FG316/U	3188	3,25 (.128)	T1025/4
FD316	3875	3,84 (.151)	T1025/9

Only common cable retention features are shown in detail. Various body configurations can apply.

AI-227 SMA Straight Connectors, Crimp Type for Braided Cable, Captive Contact

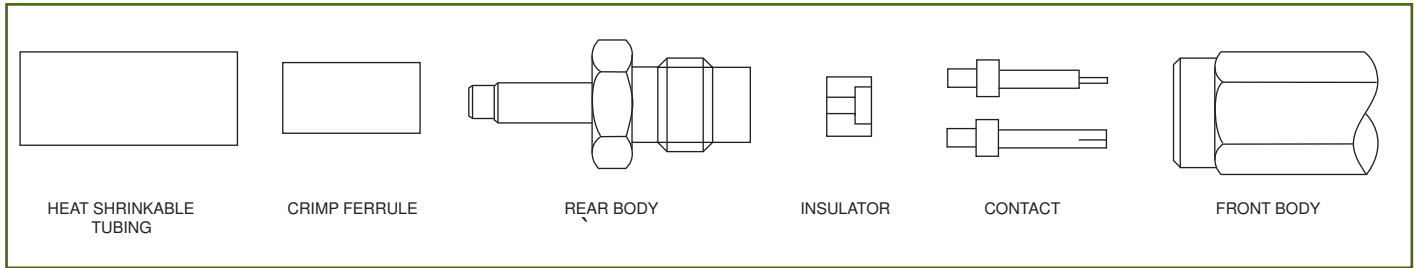

1. Slide ferrule and heat shrinkable tubing on to cable.

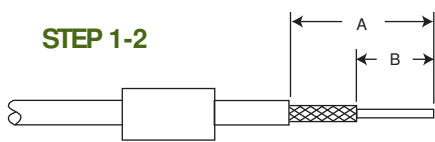

2. Trim cable to dimensions shown:

A	B	C
15,00 (.590)	9,00 (.354)	3,00 (.118)

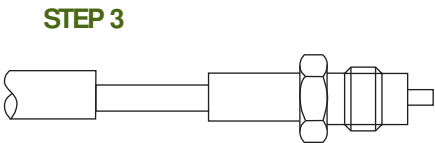

3. Slide body over cable dielectric and under the braid until the braid is flush against the rear of the hexagonal nut. NOTE: When using cables with inflexible jackets, it is permissible to make two 3,17 (.125) longitudinal slits in the outer jacket.

4. Slide ferrule flush against the body and crimp in position using Cannon's Crimp Tool and suitable Die Set (see table).

5. Trim back dielectric and center conductor to dimensions shown.

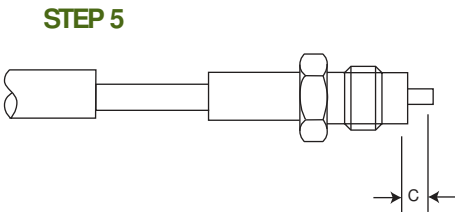

6. Tin center conductor (DO NOT OVER TIN).

7. Assemble insulator over center conductor with counterbore in direction shown.

8. Place a small solder preform made from 0,26 - 0,31 (.010 - .012) dia.(28 swg) multi-core solder in rear of contact.

9. Assemble contact on center conductor, heat to make solder connection ensuring shoulder of contact is flush against rear insulator. Do not allow solder to protrude outside spill hole.

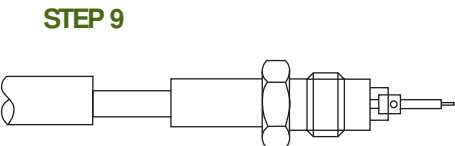

10. Insert crimped assembly into back end of body and tighten to a torque of 0.70 - 0.80 Nm (100-110 in. ozs.).

11. Slide heat shrinkable tubing over ferrule and apply heat until tubing shrinks down.

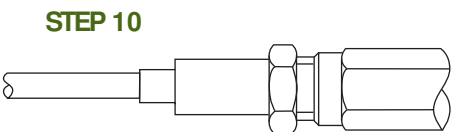

Cable Numbers	Cable Code	Die Size	Die Set
RG142/U	3196	2,67 (.105)	K29263
RG316/U	3188	3,25 (.128)	K29263
RD316	3875	3,84 (.151)	T1025/9



Dimensions shown in mm (inch)
Specifications and dimensions subject to change

www.ittcannon.com

AI-252 & AI-278

SMA Straight Connectors, Direct Solder (Separate Center Contact) Type for Semi-Rigid Cable

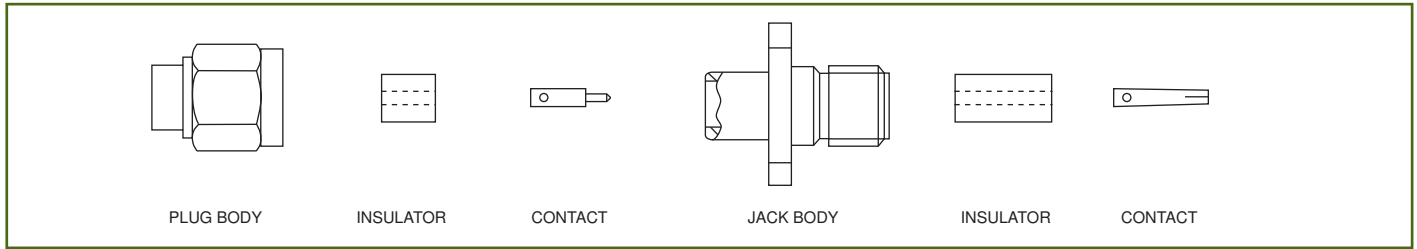

STEP 1 - 2

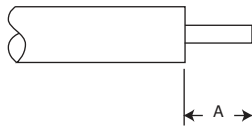

1. Cut cable end square. Trim the cable outer conductor and dielectric as shown taking care not to nick the center conductor. Deburr outer conductor at point of cut.

Assembly Instruction No	Configuration	A	B
AI-252	Plug	3,18 +/- 0,25 (.125 +/- .010)	0,38 (.015)
AI-278	Jack	2,54 +/- 0,25 (.100 +/- .010)	0,38 (.015)

STEP 3

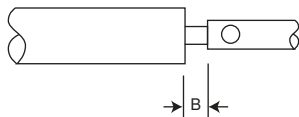

2. Tin center conductor (DO NOT OVER TIN).
3. Solder contact to center conductor ensuring that dimension shown is maintained. Remove any excess solder.
4. Clean housing area of outer conductor with abrasive paper and clean in a suitable agent.

STEP 5

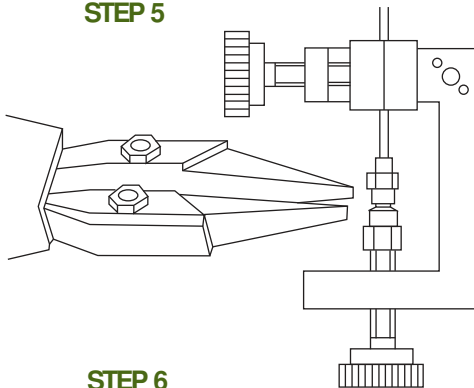

5. Place connector assembly in Assembly Jg T1848, or other suitable clamping arrangement, with contact in locator tool as shown.

Tighten screw to secure cable between inserts then tighten locator to seat cable firmly. Place solder ring around cable adjacent to connector body and heat the connector body using an appropriate heat source (solder tongs with variable control). Apply sufficient heat for solder to flow but using minimum heat cycle.

STEP 6

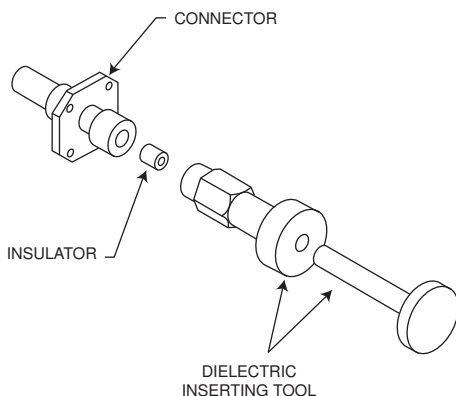

6. Using dielectric insertion Tool T2508 (for plugs) or T2509 (for jacks), press insulator into body. Assembly is now ready for use.

N.B. Various body configurations can apply.

Dimensions shown in mm (inch)
Specifications and dimensions subject to change

AI-302 SMA Straight Connectors, Direct Solder (Cable Conductor used as Center Contact) Type for Semi-Rigid Cable

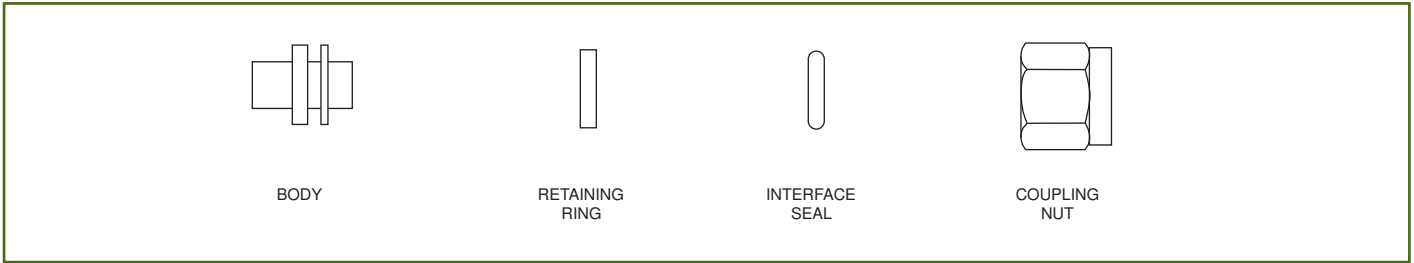

STEP 1

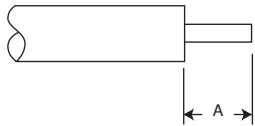

1. Trim the cable outer conductor and dielectric as shown taking care not to nick the center conductor. Deburr outer conductor at point of cut.

$$A = 2,16 \pm 0,13 \text{ (.085} \pm \text{.005)}$$

STEP 2

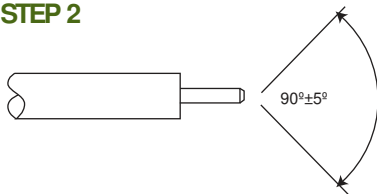

2. Point the end of the center conductor using a miniature file.
3. If style - 9073 is being assembled slip the coupling nut onto the cable.

STEP 4

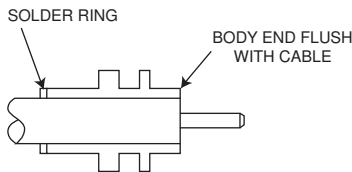

4. Clean housing area of outer conductor with abrasive paper and clean in a suitable agent. Place 24 s.w.g. soldering ring and connector body on prepared end of cable. Ensure body is correct way round. End of cable to be flush with end of connector body as shown.

STEP 5

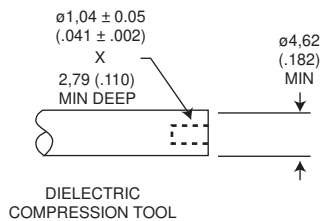

5. Compress expanded dielectric back into cable outer conductor with Dielectric Compression Tool as shown, until it is flush with end of body and outer conductor.
6. Fit the interface seal.
7. Install the spring retaining ring, compress with Tool T0557/1 and fit the coupling nut.



BAI-015 SMB Right Angle Connectors, Crimp Type for Braided Cable

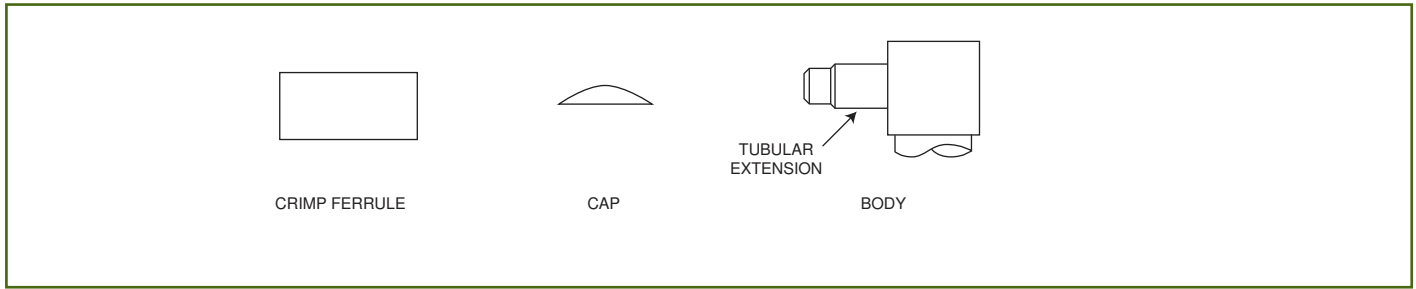

STEP 1

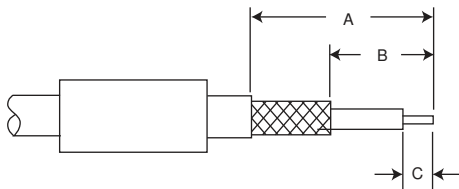

1. Trim cable to dimensions shown taking care not to nick braid or center conductor. Tin center conductor (DO NOT OVER TIN) then slip crimp ferrule over cable.

Assembly Instruction No.	A	B	C
BAI-015	10,00 (.393)	4,00 (.157)	1,50 (.059)

STEP 2

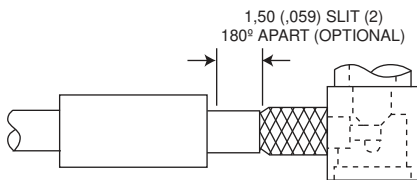

2. Insert trimmed cable into back end of body. The tubular body extension will slide under the braid with the rear portion of extension fitting under the jacket as shown. The center conductor will extend into slot in contact. NOTE: On smaller diameter cables, two longitudinal slits in the jacket, 180° apart, may be cut to ease assembly.

STEP 3

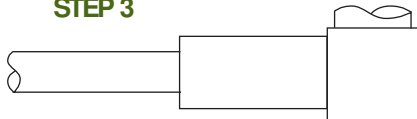

3. Slip ferrule up over braid to face of square body and crimp, using Cannon's Crimp Tool and suitable Die Set (see table).

Cable Numbers	Cable Code	Die Size	Die Set
RG142/U	9052	5,41 (.213)	K29265
RG196/U	3196	2,67 (.105)	K29263
RG316/U	0000	3,25 (.128)	K29263
RG316/U	3188	3,25 (.128)	K29263
FD316	9399	3,84 (.151)	T1025/9

4. Using a small soldering iron solder center conductor to contact. NOTE: The center conductor should not protrude beyond the contact to touch the body. Solder should not protrude beyond the slotted section of the contact.
5. Locate the cap in rear of body and dimple or lightly punch to ensure it is locked in position. (A flat punch is recommended). SUPPORT BODY ON SHOULDER DURING THIS OPERATION.

Only common cable retention features are shown in detail. Various body configurations can apply.

Dimensions shown in mm (inch)
Specifications and dimensions subject to change

BAI-003 SMB / SMC Straight Connectors, Crimp Type for Braided Cable

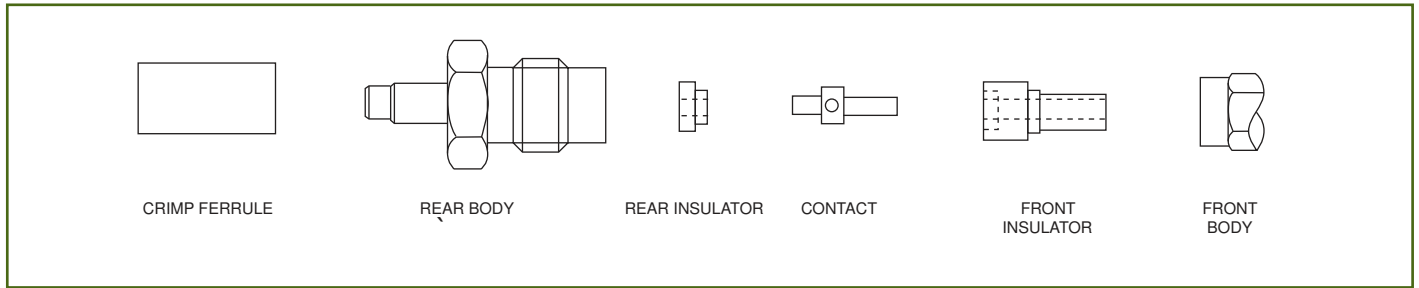

STEP 1

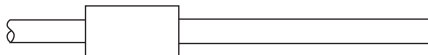

1. Slide ferrule on cable.

STEP 2

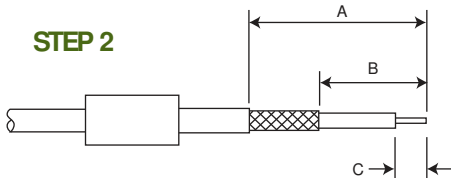

2. Trim cable to dimensions shown taking care not to nick braid or center conductor.

Assembly Instruction No.	A	B	C
BAI-003	15,50 (.610)	9,50 (.374)	2,50 (.098)

STEP 4

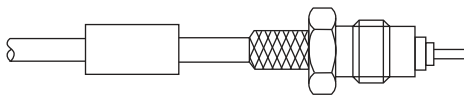

3. Tin center conductor (DO NOT OVER TIN).

4. Slide rear body over cable dielectric and under the braid until the braid is flush against the rear of the hexagonal nut. NOTE: When using cables with inflexible jackets two 3,17 (.125) slits in the outer jacket are permissible.

STEP 5

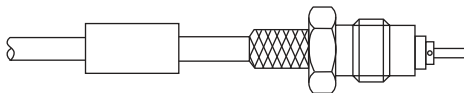

5. Slide on rear insulator so that the counterbore rests against the cable dielectric.

6. Place a small solder preform made from 0,26 - 0,31 (.010 - .012) dia (28 swg) multi-core solder in rear of contact.

7. Assemble contact on center conductor, heat to make solder connection ensuring shoulder of contact is flush against rear insulator. NOTE: Do not allow solder to protrude outside spill hole.

STEP 7

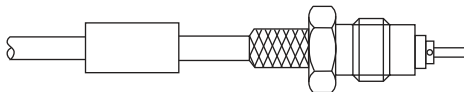

8. Slide ferrule against body and crimp using Cannon's Crimp Tool and suitable Die Set (see table below).

9. Slide on front insulator (if not already assembled in body).

10. Screw on front body and tighten to 0,63 - 0,70 Nm (90 - 100 in. ozs.)

STEP 8

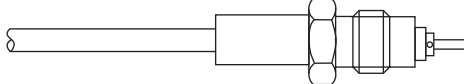

Only common cable retention features are shown in detail. Various body configurations can apply.

STEP 10

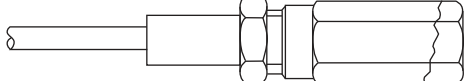

Cable Numbers	Cable Code	Die Size	Die Set
RG142/U	9052	5,41 (.213)	K29265
RG196/U	3196	2,67 (.105)	K29263
RG316/U	0000	3,25 (.128)	K29263
RD316	9399	3,84 (.151)	T1025/9



AI-703 SMA Straight Connectors, Captive Contact, Crimp Type for Braided Cable

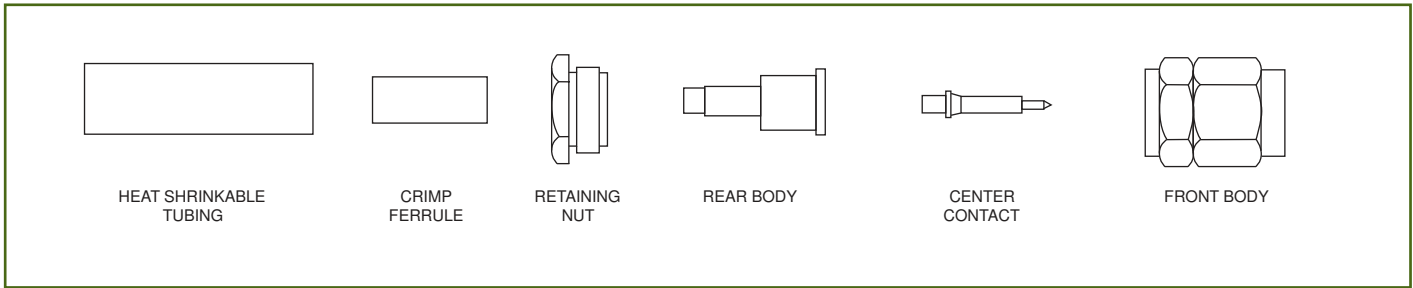

STEP 1

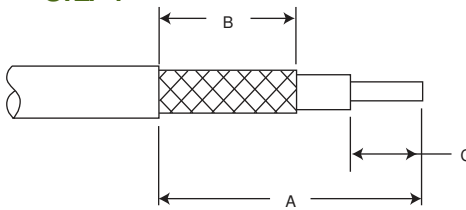

1. Strip cable to dimensions shown. Do not nick outer or inner conductors. Tin inner conductor.

A	B	C
13,46 (.530)	7,11 (.280)	3,56 (.140)

STEP 2

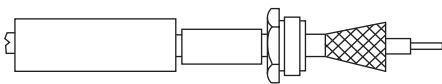

2. Place shrink tubing, crimp ferrule and retaining nut on cable. Flare the cable outer conductor as shown.

STEP 3

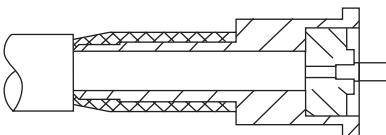

3. Insert cable dielectric into rear body until it bottoms firmly against insulator as shown.
4. Place a 0,38 (.015) dia. X 2,50 +/- 0,51 (.100 +/- .020) long solder wire into solder hole of the center contact. Heat center contact and push it over cable inner conductor until it bottoms against insulator as shown. Remove excess solder if necessary.

STEP 4

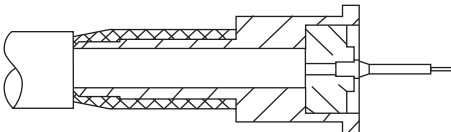

5. Insert rear body into front body. Engage threads of retaining nut to front body and hand tighten retaining nut. Hold front body firmly with a 7,93 (.312) hex. torque wrench and torque it to 1,13 - 1,69 Nm (10-15 in. lbs) by turning retaining nut only.

STEP 5

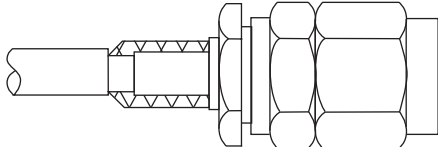

6. Slide crimp ferrule over flared portion of cable outer conductor. Crimp outer sleeve in place as shown. Push cable firmly toward connector when crimping. Trim and remove any excess outer conductor strands if necessary. Position shrink tubing over crimp sleeve apply indirect heat to shrink tubing down.

STEP 6

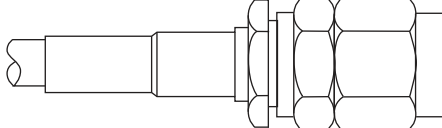

Cable Numbers	Cable Code	Die Size	Die Set
RG142/U	9142	5,41 (.213)	K29265
RG316/U	9188	3,25 (.128)	K29263
FD316	9875	3,84 (.151)	T1025/9

Dimensions shown in mm (inch)
Specifications and dimensions subject to change

BAI-001 SMB / SMC Straight Connectors, Clamp Type for Braided Cable

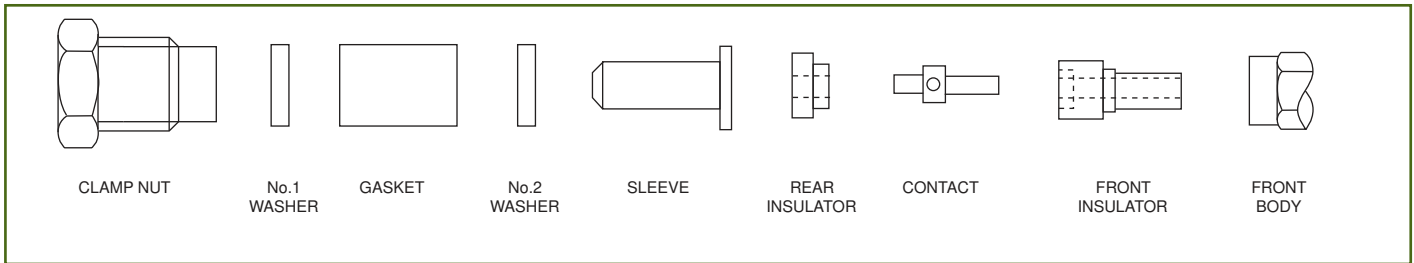

STEP 1

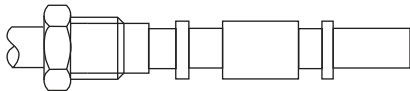

1. Slide clamp nut, No.1 washer, gasket and No.2 washer over cable.

STEP 2

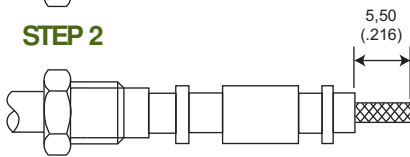

2. Trim cable to dimension shown taking care not to nick the braid.

3. Thumb braid out radially at right angles to dielectric.

STEP 3

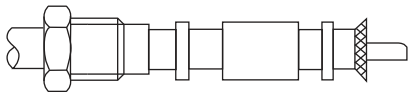

4. A small chamfer may now be cut on the end of cable dielectric, to assist assembly of sleeve.

5. Slide sleeve over cable dielectric and under braid and outer jacket until the flange of the sleeve is flush against the braid.

STEP 5

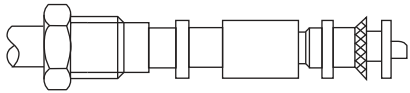

6. Move No. 2 washer up to braid and trim braid flush with the flange of the sleeve.

STEP 7

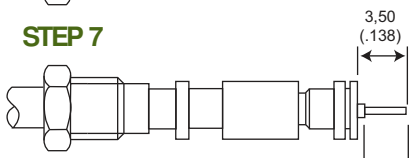

7. Trim cable dielectric and center conductor to dimensions shown taking care not to nick the center conductor.

8. Tin center conductor (DO NOT OVER TIN).

STEP 9

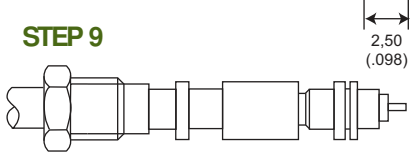

9. Slide rear insulator over cable.

10. Place a small solder preform made from 0,26 - 0,31 (.010 - .012) dia (28 swg) multi-core solder in rear of contact.

STEP 11

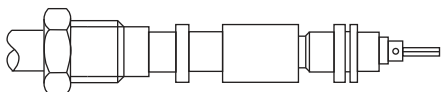

11. Push contact on center conductor as far as possible. Heat center conductor and push until the shoulder of the contact is flush against the rear insulator. Do not allow solder to protrude outside spill hole.

STEP 12

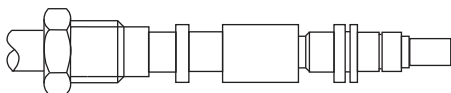

12. Slide on front insulator flush against rear insulator (if not already assembled in body).

13. Move clamp nut, No.1 washer and gasket up to No. 2 washer, slide on front body and tighten clamp nut to required torque: 0,63 - 0,70 Nm (90-100 in. ozs.)

STEP 13

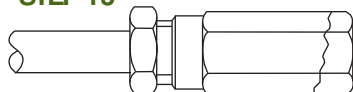

Only common cable retention features are shown in detail. Various body configurations can apply.



BBAI-1203 Coaxial Terminations, 1 and 2 Point Direct PCB

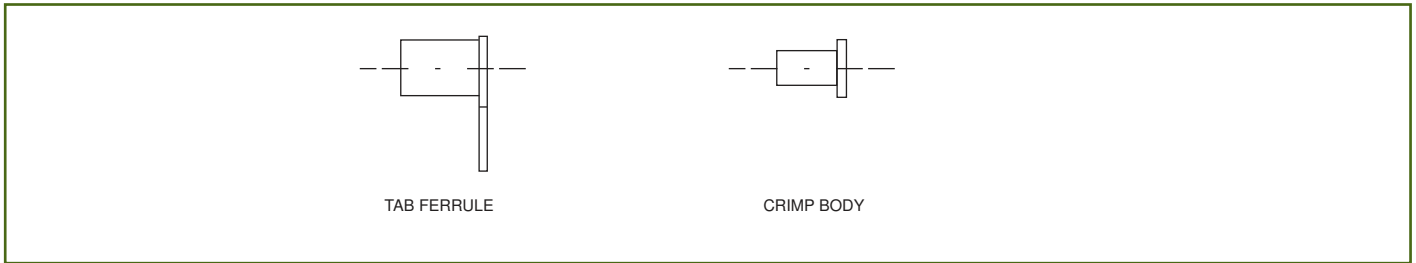

STEP 1

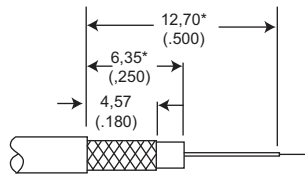

1. Trim cable to dimensions shown being careful not to nick or damage braids or center conductor. Trim center conductor. * These dimensions suit 2,54 (.100) and 7,62 (.300) PCB pitches, for other pitches see Note 4.

STEP 2

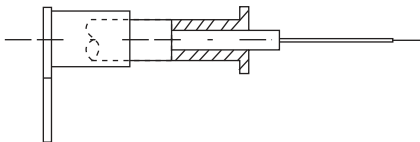

2. Side Tab-Ferrule over cable.

NOTE: Orientation of tab-ferrule is optional depending upon mounting requirements. Flare braids and slide crimp body over cable dielectric until braids meet flange on crimp body.

STEP 2

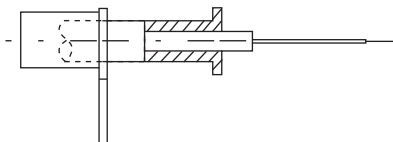

STEP 3

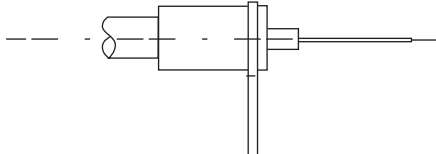

3. Side tab-ferrule over braids to face of flange and crimp using Cannon's Crimp Tool and suitable Die Set (see table).

Cable Numbers	Die Size	Die Set
FG174/U	3,25 (.128)	K29263
FG178/U	2,67 (.105)	K29263
FG179/U	3,25 (.128)	K29263
FG188/U	3,25 (.128)	K29263
FG196/U	2,67 (.105)	K29263
FG316/U	3,25 (.128)	K29263

STEP 4

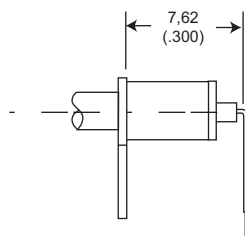

4. Bend center conductor to dimension shown depending upon preferred orientation. These dimensions suit 2,54 (.100) and 7,62 (.300) PCB pitches. For other pitches of 2,54 (.100) multiples add 2,54 (.100) multiples to the 12,70 (.500) and 6,35 (.250) dimensions in the cable stripping instructions Note 1.

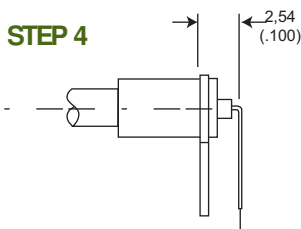

Dimensions shown in mm (inch)
Specifications and dimensions subject to change

CSMA 1 - SMA Straight Connectors, Crimp Type for Braided Cable

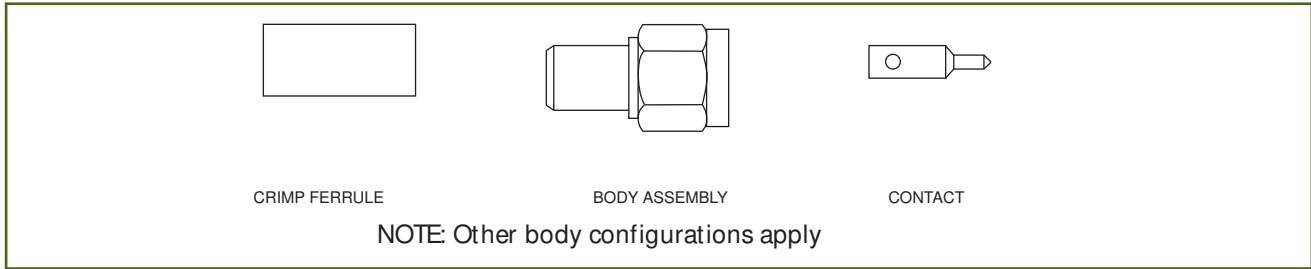

STEP 1 - 3

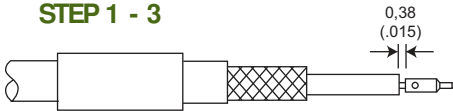

1. Side ferrule on to cable.
2. Trim cable dimension shown next to the applicable connector drawing on page 15 or page 16.
3. Solder contact attachment:
Solder contact to inner conductor.

Crimp contact attachment:

Crimp contact to inner conductor using Cannon's Hand Tool T4897 with positioner T4898 (for male contacts) and T4899 (for female contacts).

STEP 4

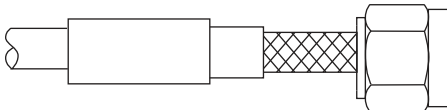

4. Insert trimmed cable into the rear of the body assembly. Tubular body extension will slide under the braid with the rear portion of extension fitting under the jacket as shown. **NOTE:** When using cables with inflexible jackets it is permissible to make two 3.17 (.125) long longitudinal slits in the outer jacket.

STEP 5

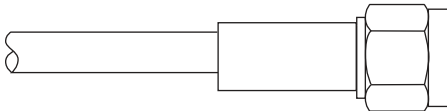

5. Slip ferrule flush against the body and crimp in position using Cannon's Crimp Tool and Suitable Die Set (see table on page 58).

CSMA 2 - SMA Right Angle Connectors, Crimp Type for Braided Cable

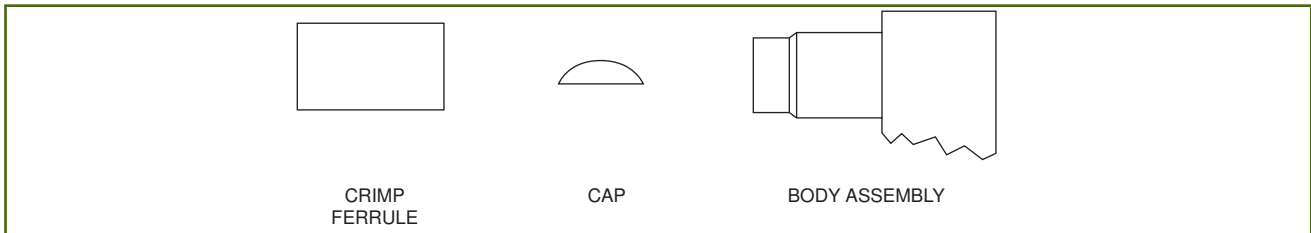

STEP 1 - 4

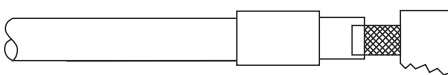

1. Side ferrule on to cable.
2. Trim cable dimension shown next to the applicable connector drawing on page 15.

STEP 5

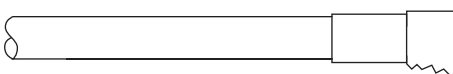

3. Tin center conductor (**DO NOT OVER TIN**).
4. Side body over cable dielectric and under the braid until braid is flush against underside of body. Ensure center conductor is located in the forked end of the contact. **NOTE:** When using cables with inflexible jackets it is permissible to make two 3.17 (.125) longitudinal slits in the outer jacket.

STEP 6

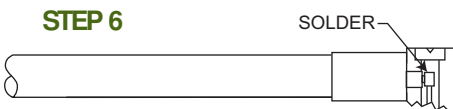

5. Side ferrule flush against the body and crimp in position using Cannon's Crimp Tool and Suitable Die Set (see table on page 58).
6. Using a small soldering iron solder center conductor to contact. **NOTE:** The center conductor should not protrude beyond the contact or touch the body. Solder should not protrude beyond the slotted section of the contact.

STEP 7

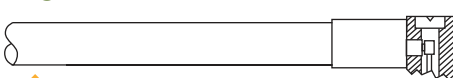

7. Locate the cap in rear of body and press flush to outer body to ensure it is locked in position.



CSMA 3 - SMA Straight Connectors, Direct Solder (Cable Conductor used as Center Contact) Type for Semi-Rigid Cable

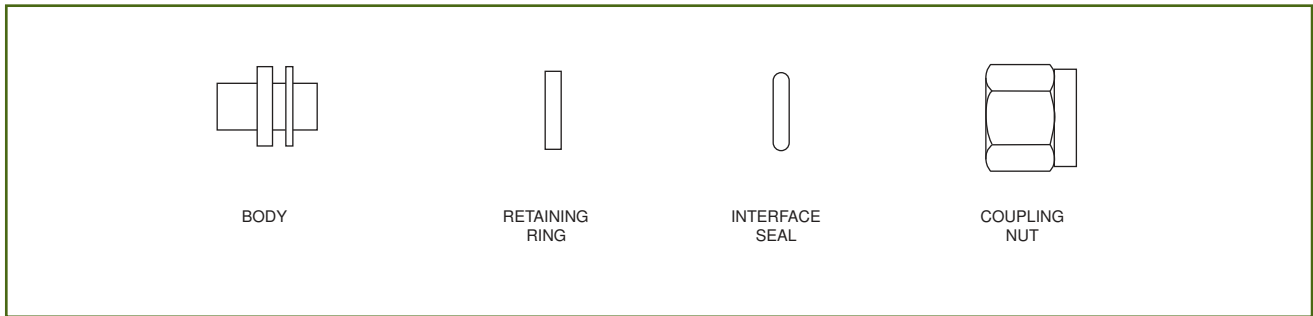

STEP 1

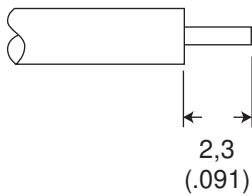

1. Remove the cable outer conductor and dielectric to the dimension shown taking care not to nick the center conductor using cable cutting tool. Deburr outer conductor at point of cut.

STEP 2

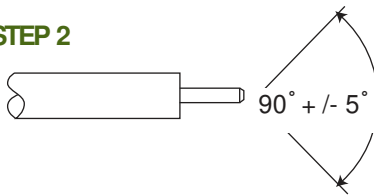

2. Point the end of the center conductor using a miniature file or suitable tool.

STEP 3

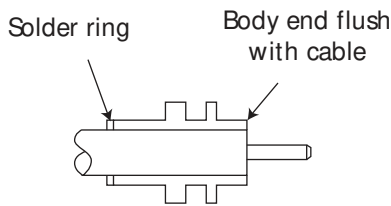

3. Clean housing area of outer conductor with abrasive paper and clean in a suitable agent. Ensure body is correct way round. Solder body ensuring end of cable to be flush with end of connector body as shown.
4. Fit the interface seal.
5. Install the spring retaining ring, compress with circlip pliers and fit the coupling nut.

**CSMA 4 - SMA Straight Connectors,
Direct Solder (Separate Center Contact) Type for Semi-Rigid Cable**

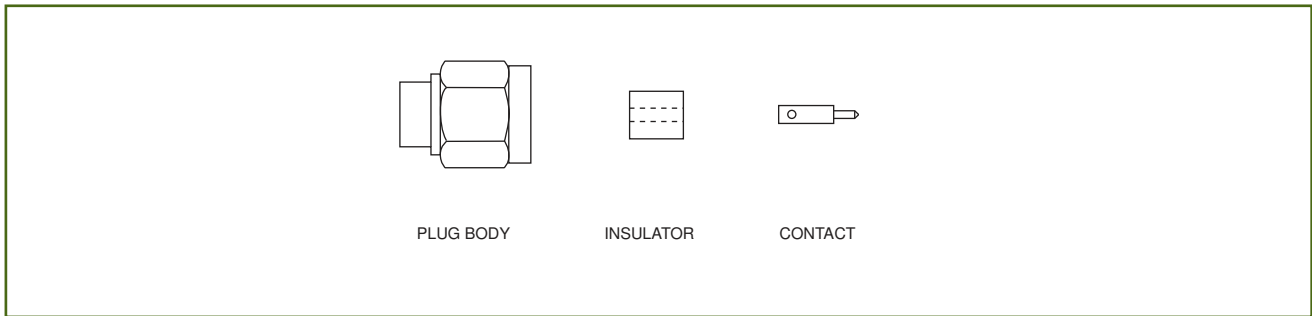

STEP 1

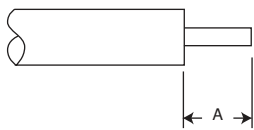

1. Cut cable end square. Remove the cable outer conductor and dielectric to the dimension shown taking care not to nick the center conductor. Deburr outer conductor at point of cut.

A	B
3.18 ± 0.25 (.125 \pm .010)	0.38 (.015)

STEP 3

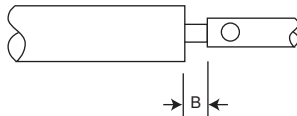

2. Tin center conductor. (DO NOT OVER TIN)
3. Solder contact to center conductor ensuring that the dimension shown is maintained. Remove any excess solder.

STEP 5

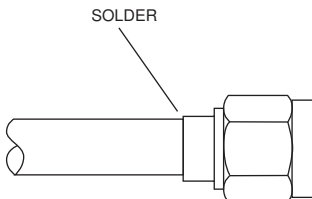

4. Clean housing area of outer conductor with abrasive paper and clean in a suitable agent.
5. Clamp the connector assembly in a suitable fixture. Ensure that the contact is in the correct interface position. Place soldering ring around cable adjacent to connector body and heat the connector body using an appropriate heat source. Apply sufficient heat for solder to flow but using minimum heat cycle.

STEP 6

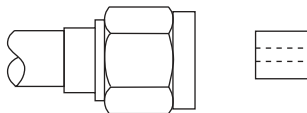

6. Using dielectric insertion Tool T2508, press insulator into body. Assembly is now ready for use.

CSMA 5 - SMA Right Angle Connectors, Direct Solder Type for Semi-Rigid Cable

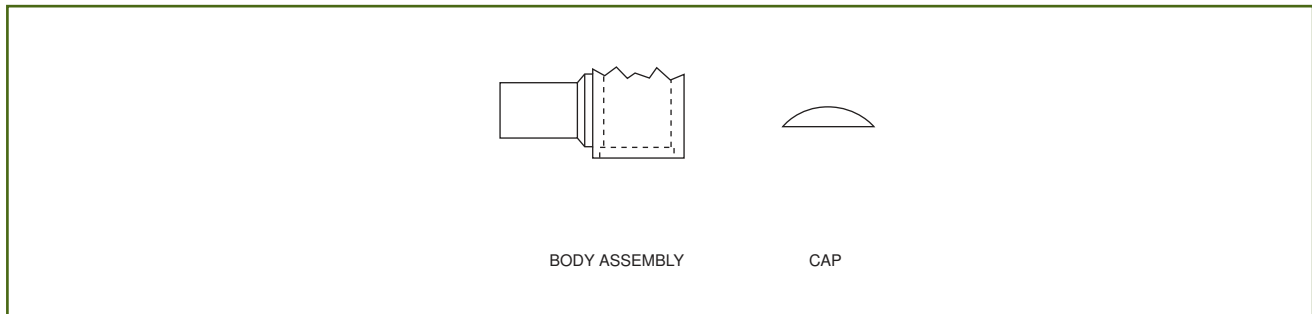

STEP 1

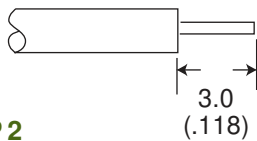

1. Remove cable outer conductor and dielectric to the dimension shown, being careful not to fracture the center conductor. Tin center conductor (DO NOT OVER TIN).

STEP 2

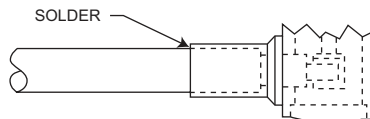

2. Slide cable into body and solder into place.

STEP 3

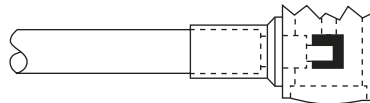

3. Solder center conductor to contact (do not over solder), then locate the cap in rear of body and press flush to outer body to ensure it is locked in position.

Centre Contact Crimp Tool

Part Number
995-001-584
Positioner for use with T4897
Part Number
T4898 for male contacts
T4899 for female contacts

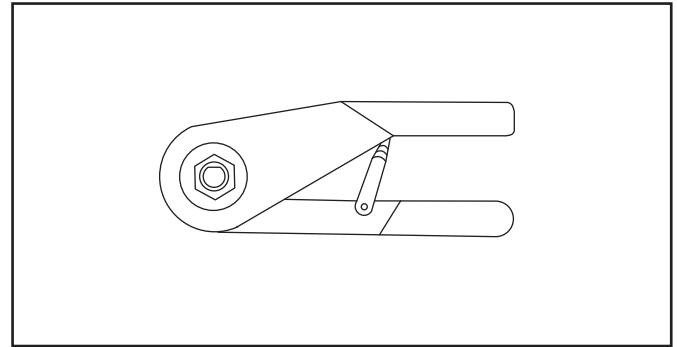

Ferrule Crimp Tool

Part Number
T1025 / -

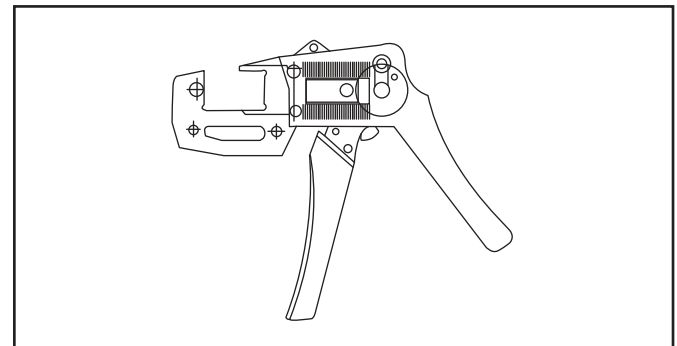

Die Set for use with T1025 / -

Part Number	Cable Numbers	Die Size	Part Number
RG141/U	9141	5.42 (.213)	K29265
RG142/U	9142	5.42 (.213)	K29265
RG316	9188	3.25 (.128)	K29263 *
RD316	9875	3.84 (.151)	T1025/9

* Three way die set (illustrated)

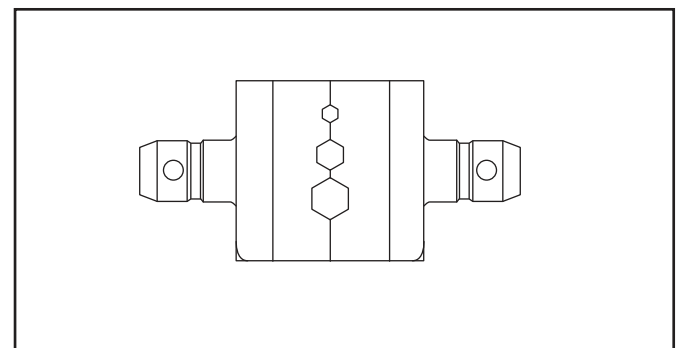

Torque Wrench (for SMA coupling nut - mating)

Jaw Size	Torque Nm (in oz)	Part Number
7.92 (.312)	0.99 - 1.06 (140-150)	T0854/12/E

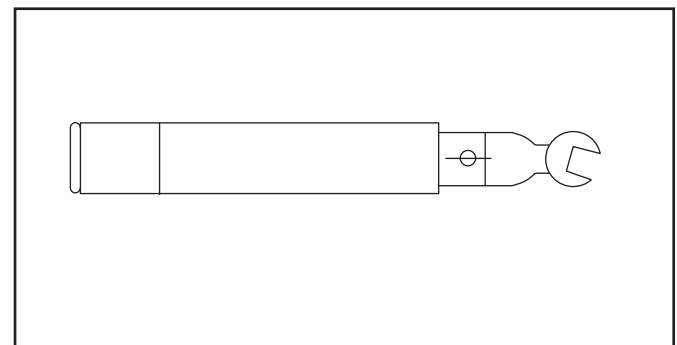

TORQUE WRENCHES

Torque Wrench Application	Jaw Size	Torque Nm (in. ozs.)	Torque Wrench Part Number
SMA Coupling Nut	7,92 (.312)	0,99-1,06 (140-150)	T0854/12/E
SMA Assembly	7,92 (.312)	0,99-1,06 (140-150)	T0854/12/E
SMA Locknut	7,92 (.312)	1,50-1,54 (212-218)	T0854/12/Z4
SMB Coupling Nut			N/A
SMB Assembly	5,57 (.219)	0,64-0,71 (90-100)	T0854/8/C
SMB Locknut	6,35 (.250)	0,71-0,78 (100-110)	T0854/10/D
SMC Coupling Nut	5,95 (.234)	0,42-0,49 (60-70)	T0854/9/A
SMC Assembly (Crimp)	5,57 (.219)	0,64-0,71 (90-100)	T0854/8/C
SMC Assembly (Clamp)	5,95 (.234)	0,64-0,71 (90-100)	T0854/9/C
SMC Locknut	6,35 (.250)	0,71-0,78 (100-110)	T0854/10/D
SSMB Coupling Nut			N/A
SSMB Assembly	3,97 (.156)	0,13-0,14 (18-20)	T0854/7/G
SSMB Locknut	4,75 (.187)	0,25-0,30 (35-50)	contact customer service
SSMC Coupling Nut	3,97 (.156)	0,18-0,21 (25-30)	T0854/7/M
SSMC Assembly	3,97 (.156)	0,13-0,14 (18-20)	T0854/7/G
SSMC Locknut	4,75 (.187)	0,25-0,30 (35-50)	contact customer service
BNC Adaptor Locknut	14,27 (.562)	2,9-3,1 (411-439)	
Type N Adaptor Coupling	17,45 (.687)	1,2-1,6 (170-227)	
Type N Adaptor Locknut	19,05 (.750)	1,8-2,2 (255-312)	

Note: This is not the entire range of Torque Wrenches. Please contact customer service for details of other styles.

CRIMP TOOLS AND DIE SETS

Description	Old Part Number	New Part Number		A/F Dimensions
Crimp Tool without Die Set	050-000-0000000	T1025/-		
Die Set for Cables RG178/U, 196U	050-000-0290000 *	K29263 * 2,67 (.105)		
Die Set for Cables RG174/U, 316/U, 179U	050-000-0290000 *	K29263 * 3,25 (.128)	* 3 way die set	2,67 (.105)
Die Set for Cable RG142/U	050-000-0291000 **	K29265 5,41 (.213)		3,25 (.128)
Die Set for Cable RD316	050-000-0292000	T1025/9 3,84 (.151)		4,52 (.178)
Die Set for Cable RG196 (for SSMB / SSMC Series)	-	T1025/1 2,67 (.105)	** 2 way die set	3,25 (.128)
Die Set for Cable RG316 (for SSMB / SSMC Series)		T1025/4 3,25 (.128)		5,41 (.213)

Note: This is not the entire range of Crimp Tools. Please contact customer service for details of other styles.

Dimensions shown in mm (inch)
Specifications and dimensions subject to change

www.ittcannon.com



Attenuation - Decrease in power due to resistance or mismatch in transmission line.

Back Mounted - When applied to a coaxial connector it is that connector mounted from the rear of a panel with the fixing nut on the outside.

Bandwidth - Distance between two frequencies over which a RF or microwave device is intended to work.

Between Series Adaptor - An adaptor used to connect two different generic types of connector.

BNC - Bayonet Nut Connector.

Braid - A weave of metal strands used as an electrical shield for an insulated conductor or group of conductors.

Bulkhead Mount - The type of connector fitted to a chassis using a single cut-out hole.

Cable Retention - The mechanism that joins the connector to the cable.

Cable Retention Force - The axial force which a connector / cable join can withstand.

Captive - A component such as a contact which is held firmly in position.

Characteristic Impedance - That impedance at which the transmission line is intended to work. A change from the characteristic impedance along its length will cause mismatch and loss of power.

Clamp - The holding of a cable by use of a screw thread action.

Closed Entry Contact - A female contact which is designed to prevent insertion of a contact larger than that specified.

Coaxial Cable - A transmission line where the one conductor is concentric inside another, often abbreviated to "coax".

Coaxial Termination - A resistive element used to end a coaxial line in its characteristic impedance.

Coaxial Terminator - A device for terminating coaxial cable to a PCB or bulkhead mount (a mechanical device and should not be confused with coaxial termination)

Conhex - Tradename covering SMB and SMC, both in 50 Ohm and 75 Ohm impedance (discontinued)

Connector Durability - The number of times a connector can be physically mated and still maintain its specified performance.

Contact Resistance - The measurement of the DC electrical resistance between a pair of mated contacts. Usually specified as being measured after a given number of mating cycles.

Corona - A discharge of electricity caused by the ionisation of the air around a conductor just prior to total breakdown or flashover.

Crimp - The action of distorting a metal tube to give intimate contact with a conductor; a good crimp should be gas tight and not be impacted by environmental change.

Crimp Dies - The tool inserts which determine the shape of the distortion to create a consistently good crimp.

Crimp Tool - The tool which holds crimp dies to apply the necessary force.

Cross Talk - The amount of signal which may be transferred from one signal carrying line to an adjacent line.

Out Of Frequency - The frequency at which the loss exceeds a predetermined level.

Decibel (dB) - A unit of measurement of RF power loss.

Dielectric - The insulating medium which holds the center conductor concentric within the connector or cable.

Dielectric Constant - The electrical value of dielectric which determines the impedance in cables or connectors

with constant diameters.

Dielectric Withstanding Voltage - The maximum voltage that a dielectric material can withstand without failure.

Direct Solder - A common method of terminating connectors to semi-rigid cable by soldering the cable jacket to the connector.

Discontinuity - A dramatic change in characteristic impedance which gives rise to a reflected wave.

Dissipation - The unused or lost energy in a system e.g. heat.

Distortion - An unwanted change in a signal wave form.

Dummy Load - A device connected to the end of a transmission line to absorb transmitted power and prevent reflected energy.

Dust Cap - A mechanical device attached to the mating face of an unmated connector to prevent ingress of contaminants and provide protection against mechanical damage.

Electromagnetic Compatibility (EMC) - The ability of a device to operate within its intended environment without being effected by or generating electromagnetic interference (EMI).

Engagement and Separation Forces - The forces required to mate and unmate a pair of connectors. The forces are usually specified as a max & min for each action.

Environmentally Sealed - A connector that is provided with seals or other devices to prevent ingress of dust, moisture or other contaminants while mated which might impair performance.

Flexible Cable - A coaxial cable where the outer conductor is flexible (usually braided).

Gigahertz (GHz) - A measure of frequency representing 1 billion Hertz (cycles per second).

Impedance - See 'Characteristic Impedance'

In-Series Adaptor - An adaptor which enables the connection of two connectors of the same generic type.

Insertion Loss - The loss of power due to a particular component in a transmission line (e.g. cable).

Insulation Resistance - The electrical resistance between two conductors separated by an insulating medium.

Intermodulation - The mixing of two or more frequencies which are not intended to mix.

Interface - The two surfaces of a connector which come into intimate contact when the two halves are mated.

Inter-series Adaptor - See 'Between Series Adaptor'

Isolation - The measure of interaction between two or more transmission lines.

Jack - One half of a mating pair of connectors. The jack interface normally goes inside the plug interface.

Mean Power - The mean value of the rate at which energy is transmitted from one place to another.

Micro Strip - A transmission line consisting of a flat conductor on a dielectric above a single ground plane. (the ground plane is frequently a metalized face of the dielectric).

Microwave - Very short electromagnetic waves. Frequency range above 1 GHz.

MIL-C-39012 - The generic specification covering USA Military coaxial connectors.

MIL-C-17 - The generic MIL spec covering coaxial cables.

Mismatch - The condition in which the impedance of the source and load are not the same. This reduces power transfer and causes reflections.

Mounting Plan - The design of the PCB or panel cut-out used to mount the connector.

N Connector - This was the first true microwave

connector capable of working to 18 GHz, initially designed for test applications.

Nanohex - Trade name covering SSMB & SSMC (discontinued)

Noise - An external electromagnetic signal which interferes with the desired signal.

Non-captive - A component such as a contact which does not have a retention feature.

Passivation - This is a surface treatment applied primarily to stainless steel. The process removes contaminating iron particles and produces a passive surface.

Peak Power - Is the maximum power which may be handled by a connector or cable.

Plug - One half of a mating pair of connectors. The plug interface normally goes outside the jack interface.

POSNS - Abbreviation for "positions".

PTFE - Abbreviation of polytetrafluorethylene. This is the most commonly used dielectric (insulator) used in professional coaxial connectors.

QPL - Qualified Parts List. Parts approved to MIL-C-390 12 specification.

Receptacle - A term used to describe a connector assembly usually bulkhead or PCB mounted.

Return Loss - A reason for losing RF energy due to signals being reflected due to a mismatch in a transmission line.

RF Leakage - The RF power lost from a transmission line or device. Measured in dB.

RG - The traditional prefix for MIL spec coaxial cables.

Screw-on - The mating action of connectors which are joined using a screw thread (e.g. SMC)

Sealflex2™ - Cannon trade name for a flexible microwave cable assembly which has a performance similar to semi-rigid cable.

Semi-rigid Cable - A coaxial cable where the outer conductor is a solid metal tube.

Skin Effect - The tendency of alternating currents to flow near to the surface of a conductor; this increases resistance and becomes more marked the higher the frequency.

SMD - Sometimes used as an abbreviation for slide-on variants of SMB. This is a misnomer, the more common use is for Surface Mount Device.

Snap-on - A term used to describe the mating action of SMB and SSMB connectors.

Solderless SMA - An SMA connector that can be connected to semi-rigid cable by compressing the inner body rather than by soldering (sometimes referred to as semi-rigid 'crimp' connectors).

Stripline - A method of building a microwave circuit. The circuitry is sandwiched between 2 ground planes. Sometimes referred to as Tri-plate.

Teflon - DuPont tradename for PTFE.

Tensile Strength - The greatest force a device can withstand without tearing or pulling apart. This is frequently the method of determining the effectiveness of a crimp.

TNC - Thread Nut Connector same size as BNC; the only obvious difference is the coupling nut.

Tri-plate - See Stripline.

UG Symbol - Used to indicate a connector made to US government spec.

Voltage Standing Wave Ratio (VSWR) - A way of expressing the resultant loss of power as a result of signal reflections due to discontinuity.

Part Number	Page	Part Number	Page	Part Number	Page
050-007-0000220	24	051-427-3188220	29	B51-024-0000220	21
050-024-0000220	24	051-443-0000220	29	B51-024-3196220	21
050-027-0000220	24	051-445-0000220	30	B51-024-9399220	21
050-043-0000220	25	051-452-0000220	30	B51-051-9029220	23
050-045-0000220	25	055-607-2003890	9	B51-053-0000220	23
050-047-0000220	25	055-607-9172890	9	B51-053-9029220	23
050-074-6201310	35	055-607-9173890	9	B51-328-3188220	21
050-424-3188220	31	055-611-3702890	9	B51-328-3196220	21
050-424-3196220	31	055-611-3703890	9	B51-328-9019AU0	21
050-428-3188220	31	055-939-9019AR6	33	B51-328-9399220	21
050-428-3196220	31	055-939-9029AR6	33	B51-351-0000220	23
050-443-0000220	31	055-939-9039AR6	34	F50-E22-9141000	15
050-445-0000220	31	055-939-9049AR6	34	F50-E22-9142000	15
050-451-0000220	32	055-939-9059AR6	34	F50-E22-9188000	15
050-453-0000220	32	055-939-9069AR6	34	F50-E22-9875000	15
050-622-9188890	8	065-9AA-0300000	39	F50-E27-9188000	16
050-622-9875890	8	065-9AA-0500000	39	F50-E27-9875000	16
050-627-9188890	8	065-9AA-0750000	39	F50-E28-9141000	15
050-627-9875890	8	065-9AA-1000000	39	F50-E28-9142000	15
050-628-9188890	8	065-9AA-1500000	39	F50-E28-9188000	15
050-628-9875890	8	065-9AA-2000000	39	F50-E28-9875000	15
050-645-4528890	10	065-9AA-2000000	39	F50-E51-0000000	16
050-645-4540890	10	065-9AS-0500000	39	F50-E53-0000000	16
050-645-4575890	10	065-9AS-1000000	39	F55-E07-2003000	17
050-645-9009890	10	065-9AS-2000000	39	F55-E07-9172000	17
050-651-0000310	11	065-9SS-0500000	39	F55-E07-9173000	17
050-653-0000310	11	065-9SS-1000000	39	F55-E11-3702000	17
050-673-0000890	12	065-9SS-2000000	39	F55-E11-3703000	17
050-674-0000890	12	065-9SS-3000000	39	K29263	59
050-674-6302310	35	A50-624-9188890	8	K29265	59
050-674-6324990	36	A50-624-9875890	8	T0854/10D	59
050-674-6700890	36	A51-424-3196220	29	T0854/12/E	59
050-675-0000890	12	A51-427-3196220	29	T0854/12/Z4	59
050-675-6705890	36	A51-428-3188220	29	T0854/7/G	59
050-675-6801890	36	A51-428-3196220	29	T0854/7/M	59
050-678-0000890	12	A51-428-3875220	29	T0854/8/C	59
051-027-0000220	21	A51-451-0000220	30	T0854/9/A	59
051-027-3196220	21	A51-453-0000220	30	T0854/9/C	59
051-027-9399220	21	B50-051-0000220	26	T1025/-	58
051-043-0000220	22	B50-051-9019220	26	T1025/1	58
051-045-0000220	22	B50-053-0000220	26	T1025/9	59
051-047-0000220	22	B50-053-9019220	26	T4897	58
051-075-0000220	21	B50-328-3188220	24	T4898	58
051-424-3188220	29	B50-328-9399220	24	T4899	58

THIS NOTE MUST BE READ IN CONJUNCTION WITH THE PRODUCT DATA SHEET/CATALOG. FAILURE TO OBSERVE THE ADVICE IN THIS INFORMATION SHEET AND THE OPERATING CONDITIONS SPECIFIED IN THE PRODUCT DATA SHEET/CATALOG COULD RESULT IN HAZARDOUS SITUATIONS.

1. MATERIAL CONTENT AND PHYSICAL FORM

Electrical connectors do not usually contain hazardous materials. They contain conducting and non-conducting materials and can be divided into two groups.

a) Printed circuit types and low cost audio types which employ all plastic insulators and casings.

b) Rugged, Fire Barrier and High Reliability types with metal casings and either natural rubber, synthetic rubber, plastic or glass insulating materials. Contact materials vary with type of connector and also application and are usually manufactured from either: Copper, copper alloys, nickel, alumel, chromel or steel. In special applications, other alloys may be specified.

2. FIRE CHARACTERISTICS AND ELECTRIC SHOCK HAZARD

There is no fire hazard when the connector is correctly wired and used within the specified parameters. Incorrect wiring or assembly of the connector or careless use of metal tools or conductive fluids, or transit damage to any of the component parts may cause electric shock or burns. Live circuits must not be broken by separating mated connectors as this may cause arcing, ionization and burning. Heat dissipation is greater at maximum resistance in a circuit. Hot spots may occur when resistance is raised locally by damage, e.g. cracked or deformed contacts, broken strands of wire. Local overheating may also result from the use of the incorrect application tools or from poor quality soldering or slack screw terminals. Overheating may occur if the ratings in the product Data Sheet/Catalog are exceeded and can cause breakdown of insulation and hence electric shock. If heating is allowed to continue it intensifies by further increasing the local resistance through loss of temper of spring contacts, formation of oxide film on contacts and wires and leakage currents through carbonization of insulation and tracking paths. Fire can then result in the presence of combustible materials and this may release noxious fumes. Overheating may not be visually

apparent. Burns may result from touching overheated components.

3. HANDLING

Care must be taken to avoid damage to any component parts of electrical connectors during installation and use. Although there are normally no sharp edges, care must be taken when handling certain components to avoid injury to fingers. Electrical connectors may be damaged in transit to the customers, and damage may result in creation of hazards. Products should therefore be examined prior to installation/use and rejected if found to be damaged.

4. DISPOSAL

Incineration of certain materials may release noxious or even toxic fumes.

5. APPLICATION

Connectors with exposed contacts should not be selected for use on the current supply side of an electrical circuit, because an electric shock could result from touching exposed contacts on an unmated connector. Voltages in excess of 30 V ac or 42.5 V dc are potentially hazardous and care should be taken to ensure that such voltages cannot be transmitted in any way to exposed metal parts of the connector body. The connector and wiring should be checked, before making live, to have no damage to metal parts or insulators, no solder blobs, loose strands, conducting lubricants, swarf, or any other undesired conducting particles. Circuit resistance and continuity check should be made to make certain that there are no high resistance joints or spurious conducting paths. Always use the correct application tools as specified in the Data Sheet/Catalog. Do not permit untrained personnel to wire, assemble or tamper with connectors. For operation voltage please see appropriate national regulations.

IMPORTANT GENERAL INFORMATION

(i) Air and creepage paths/Operating voltage. The admissible operating voltages depend on the individual applications and the valid national and other applicable safety regulations. For this reason the air and creepage path data are only reference values. Observe reduction of air and creepage paths due to PC board and/or harnessing.

(ii) Temperature

All information given are temperature limits. The operation temperature depends on the individual application.

(iii) Other important information

Cannon continuously endeavors to improve their products. Therefore, Cannon products may deviate from the description, technical data and shape as shown in this catalog and data sheets.

“Engineered for life” is a registered trademark of ITT Corporation © 2007. All other trademarks or registered trademarks are property of their respective owners. All data subject to change without notice.

Product Warranty

ITT Electronic Components, a Division of ITT Corporation manufactures the highest quality products available in the marketplace; however these products are intended to be used in accordance with the specifications in this publication. Any use or application that deviates from the stated operating specifications is not recommended and may be unsafe. No information and data contained in this publication shall be construed to create any liability on the part of Cannon. Any new issue of this publication shall automatically invalidate and supersede any and all previous issues. A limited warranty applies to Cannon products. Except for obligations assumed by Cannon under this warranty, Cannon shall not be liable for any loss, damage, cost of repairs, incidental or consequential damages of any kind, whether or not based on express or implied warranty, contract, negligence or strict liability arising in connection with the design, manufacture, sale, use or repair of the products. Product availability, prices and delivery dates are exclusively subject to our respective order confirmation form; the same applies to orders based on development samples delivered. This publication is not to be construed as an offer. It is intended merely as an invitation to make an offer. By this publication, Cannon does not assume responsibility or any liability for any patent infringements or other rights of third parties which may result from its use. Reprinting this publication is generally permitted, indicating the source. However, Cannon's prior consent must be obtained in all cases.



ITT

Customer Support Locations

ASIA

Tuopandun Industrial Area, Jinda Cheng,
Xiner Village, Shajing Town,
Baoan District, Shenzhen City,
Guangdong, China 518125
Tel: +86 755 2726 7238
Fax: +86 755 2726 7515

GERMANY

Cannonstrasse 1
Weinstadt, 71364
Tel: +49.7151.699.0
Fax: +49.7151.699.217

ITALY

Corso Europa 41/43
Lainate (MI),
Italy 20020
Tel: +39.02938721
Fax: +39.0293872300

UK

Jays Close, Viables Estate
Basingstoke, Hants, RG22 4BA
Tel: +44.1256.311200
Fax: +44.1256.323356

USA

100 New Wood Road
Watertown, CT 06796
Tel: 860.945.0206
Toll Free: 800.683.7666
Fax: 860.645.0303

www.ittcannon.com

©2007 ITT Corporation. "Engineered for life" and "Cannon" are registered trademarks of ITT Corporation. Specification and other data are based on information available at the time of printing, and are subject to change without notice.

ITT Cannon 50 RF Catalog 20170721