

LED ENGINE

4W ZERO EMI

600 LUMEN



LDZ-56WW-01-xx (12 or 24VDC)

Lunasea LED Light Engine. Offering 600 lumens of 2700K Warm White light output with a color rendering of >80 CRI. Beam angle of 120 degree great for area lighting. 12 or 24VDC applications. Circuitry has Zero Emissions. Surge protection. Built in thermal protection throttles back current to LEDs if PCB experiences excessive heat.

- Small Size - 33.6mm (1.32") Diam
- 48V Surge Supression
- Zero EMI Emissions
- Diode Protection Inputs
- On-Board Thermal Regulation
- PWM Dimmable

PCB Aluminum Clad

Power: 4 Watt
Voltage 12 or 24VDC

Output: 600 Lumen >80CRI
Dimensions: 33.6 (1.32") D x 1.6 (0.063") D

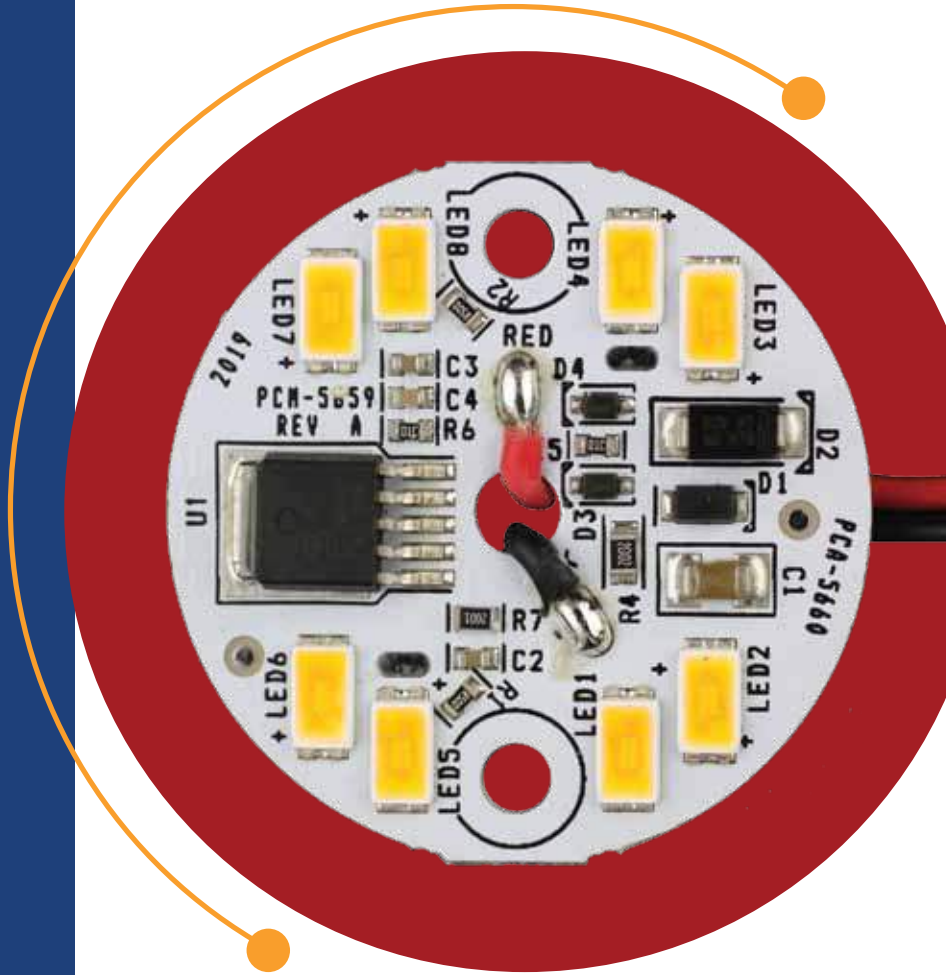

LDZ-56WW-01-00 Warm White (2700K) 12VDC
LDZ-56WW-01-24 Warm White (2700K) 24VDC

THIS PRODUCT REQUIRES HEATSINK

Recommended Heatsink

A heatsink with a surface area of 18 External Square inches is recommended for this LED Engine. Insufficient heatsink may cause damage to the PCB and its components.

Typical Characteristics Graphs



Spectrum Distribution

CCT: 2700K (85 CRI)

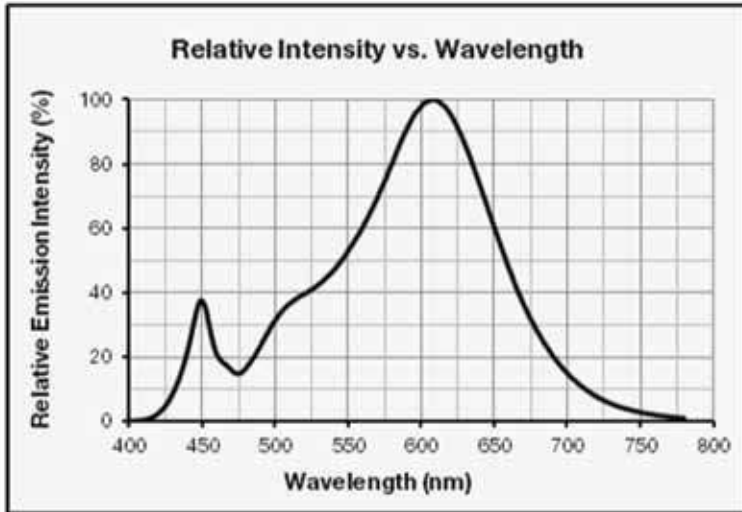

Beam Angle Characteristics

T_s = 25 °C)

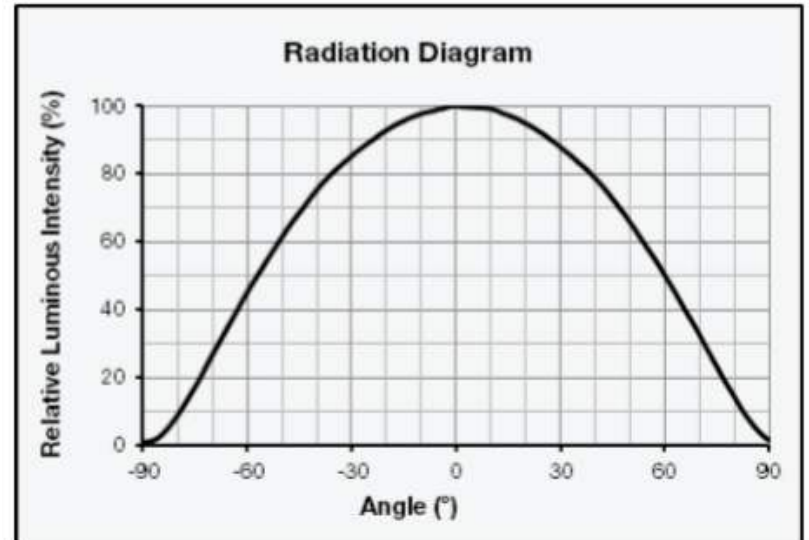

Electrical

LDZ-56WW-01-xx

Two Wire

- Red: Positive
- Black: Ground

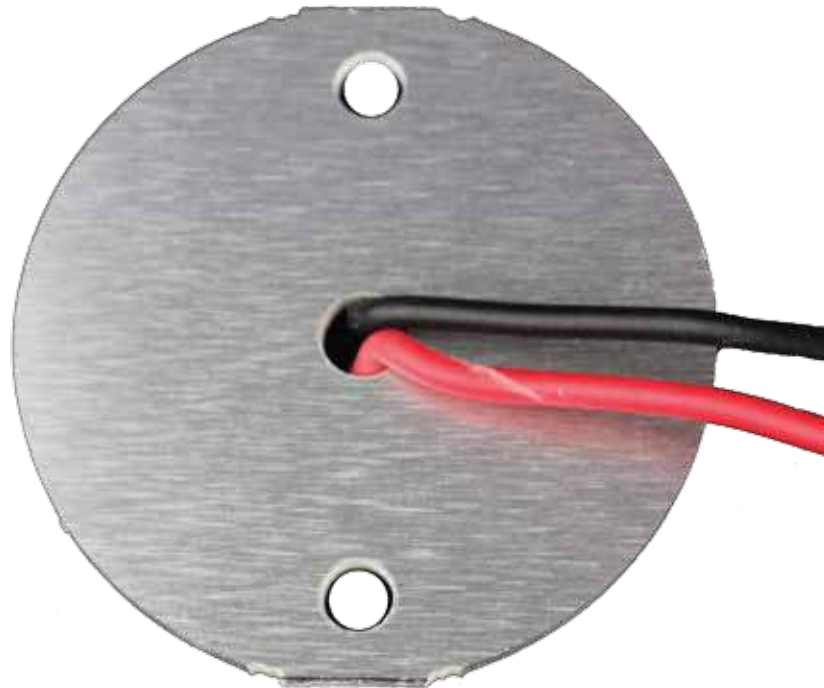

Digital (PWM) dimming compatible. (External Dimmer required)

Mechanical Dimensions

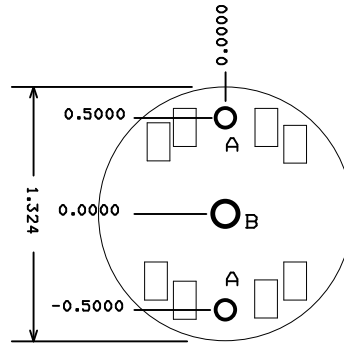

LDZ-56WW-01-00
DIMENSION IN INCHES
BOARD IS ALUMINUM CLAD
Thickness .063 inches
HOLE SIZES
A= 0.125
B= 0.157

NEW ZERO EMI LIGHTING

INTRODUCING ZERO EMI LIGHTING

This means no AIS or VHF Interference

All light, no EMI! With Zero radio emissions these lights can't interfere with your communication and navigation equipment. Same powerful output & high color rendering.

**They are
not just quiet
They are SILENT!**

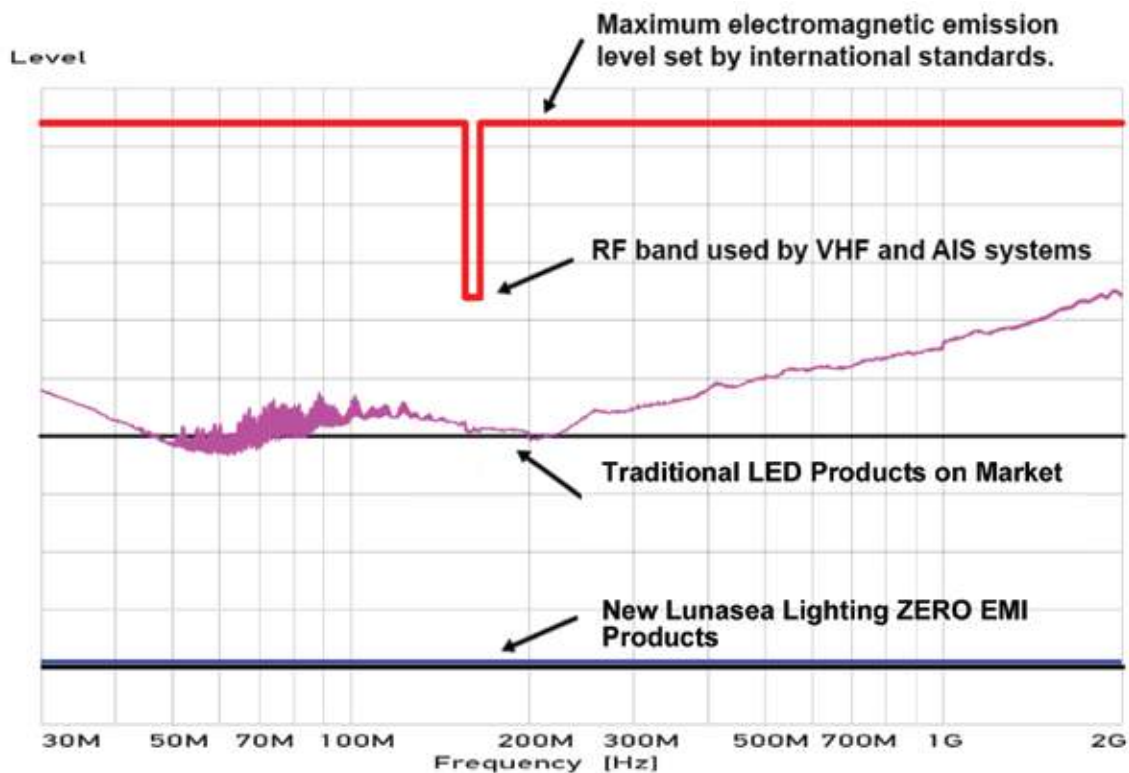

Thermal & Mechanical Design



Heat Sink Thermal Resistance

Thermal design is critical for optimal performance of the Lunasea LED engine, and it is important to choose a suitable heat sink. Design attributes such as heat sink size and shape, active or passive cooling options, material, surface finishes, and etc. need to be selected so that the thermal resistance of the heat sink is optimized for the specific environment the fixture will be operating in.

Thermal Design Guidance

A good thermal design requires very good heat transfer from the Lunasea LED PCB to the heat sink. In order to minimize air gaps and contact resistance between the PCB and the heat sink, it is common practice to use thermal interface materials (TIM) such as thermal pastes, thermal pads, phase change materials and thermal epoxies. Each material has its pros and cons depending on the design. Thermal interface materials are most efficient when the mating surfaces of the board and the heat sink are flat and smooth. Rough and uneven surfaces may have gaps with higher thermal resistances, increasing the overall thermal resistance of this interface. It is critical that the thermal resistance of the interface is low, allowing for an efficient heat transfer to the heat sink and keeping LED PCB temperatures low.

Mechanical Mounting Considerations

The mounting of Lunasea LED Engine is a critical process step. Excessive mechanical stress in the board can cause the board to warp, which can lead to substrate cracking and subsequent cracking of the LED dies.

Recommended Heatsink

A heatsink with a surface area of 18 External Square inches is recommended for this LED Engine. Insufficient heatsink may cause damage to the PCB and its components.



RoHS Compliance

LuxiTune products do not contain any restricted hazardous substances (RoHS) with levels above the threshold limits permitted in accordance with EU Directive 2011/65/EU on the restriction of the use of certain hazardous substances in electrical and electronic equipment. Declarations for this product can be obtained from your local LED Engine representative.

About Lunasea Lighting

Founded in 2004, as a subsidiary of Digitron Electronics, Lunasea was born with military and medical equipment grade design and manufacturing pedigree established through decades innovative electronics development. Lunasea Lighting's technology uses revolutionary microprocessor-controlled circuitry that is based on 25 years of research and development. These capabilities and technology enable Lunasea to provide LED lighting products that are designed and constructed to withstand the world's most harsh environments.

Today, through its design and manufacturing facility in Homosassa Florida, Lunasea offers roughly 250 lighting related products that range from LED Light Engines, festoon to high powered, explosion proof flood lights. All products are designed in this U.S. facility.