



Electrical specifications

Center Frequency: 1000 MHz
Bandwidth: 35 MHz typ
VSWR: 1.5:1
Input / Output Impedance: 50 Ohms
Passband: 982.5-1017.5 MHz
Passband Insertion Loss: 3.0 dB max
Passband Ripple: 0.7 dB max
Rejection: 50 dB min at 865 MHz
Rejection 2: 50 dB min at 1135 MHz
Power Handling: 1 W

Mechanical

Mounting Method: SMT
Dimensions: 18.2mm x 14mm x 5mm

Environmental

Operating Temperature: -20°C to 70°C
Storage Temperature: -50°C to +90°C

This product is RoHs compliant.

Outline Drawing:

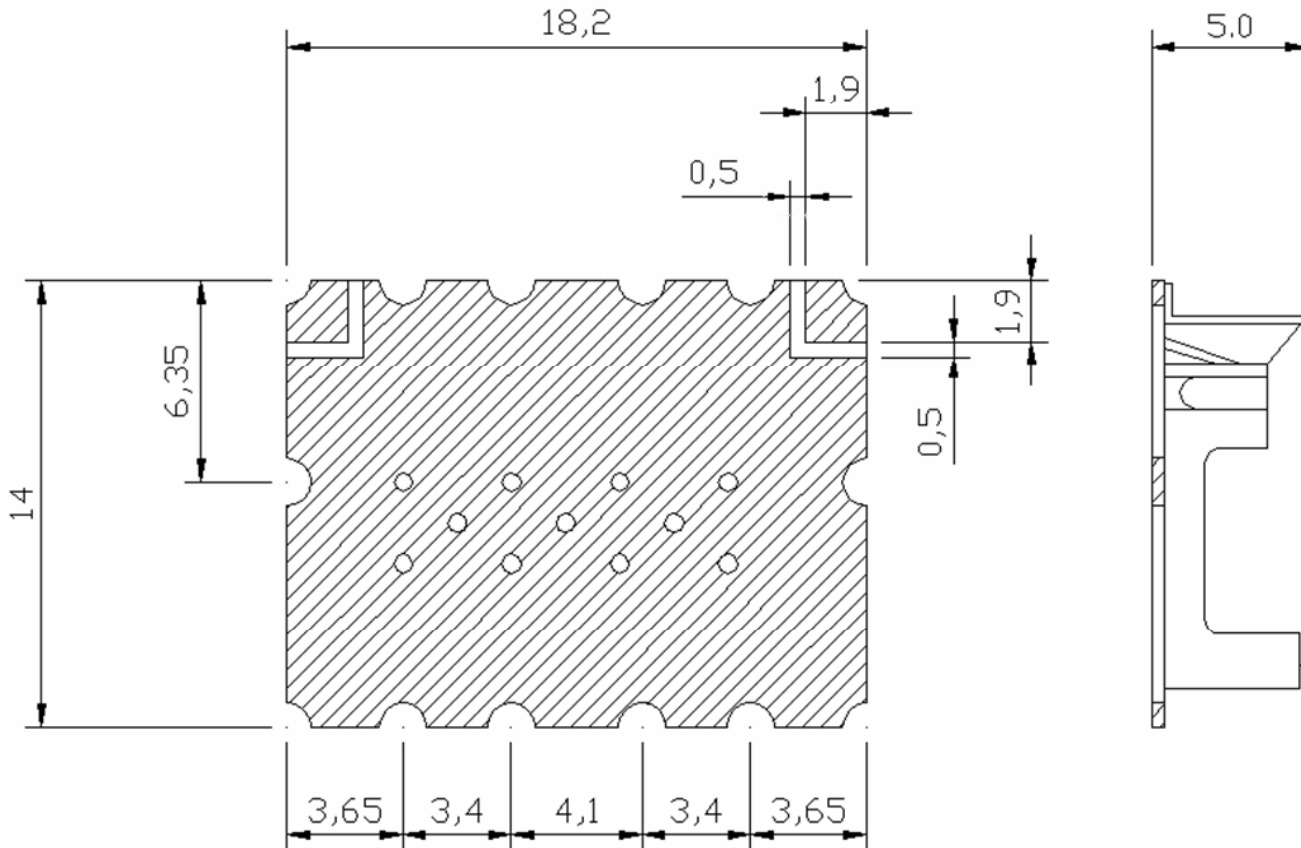

Unit : mm

Tolerance : ± 0.3