

■ Dimensions

Note: All units are in millimeters unless otherwise indicated.

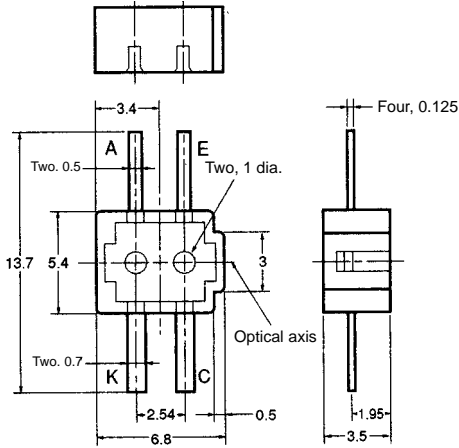

Internal Circuit

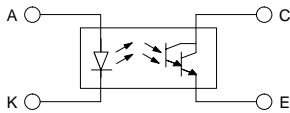

Unless otherwise specified, the tolerances are as shown below.

| Dimensions | Tolerance |
|--------------|-----------|
| 3 mm max. | ±0.3 |
| 3 < mm ≤ 6 | ±0.375 |
| 6 < mm ≤ 10 | ±0.45 |
| 10 < mm ≤ 18 | ±0.55 |
| 18 < mm ≤ 30 | ±0.65 |

| Terminal No. | Name |
|--------------|-----------|
| A | Anode |
| K | Cathode |
| C | Collector |
| E | Emitter |

■ Features

- The LED requires a forward current of only 5 mA due to the Photo-Darlington transistor built into the detector.
- With a red LED light source.

■ Absolute Maximum Ratings (Ta = 25°C)

| Item | Symbol | Rated value |
|-----------------------|---------------------------|--------------------------|
| Emitter | Forward current | I_F 15 mA (see note 1) |
| | Pulse forward current | I_{FP} --- |
| | Reverse voltage | V_R 4 V |
| Detector | Collector-Emitter voltage | V_{CEO} 24 V |
| | Emitter-Collector voltage | V_{ECO} --- |
| | Collector current | I_C 20 mA |
| | Collector dissipation | P_C 50 mW (see note 1) |
| Ambient temperature | Operating | T_{opr} -20°C to 60°C |
| | Storage | T_{stg} -20°C to 80°C |
| Soldering temperature | T_{sol} | 260°C (see note 2) |

- Note:**
1. Refer to the temperature rating chart if the ambient temperature exceeds 25°C.
 2. Complete soldering within 10 seconds.

■ Electrical and Optical Characteristics (Ta = 25°C)

| Item | Symbol | Value | Condition |
|--------------|--------------------------------------|--|--|
| Emitter | Forward voltage | V_F 2.0 V typ., 2.6 V max. | $I_F = 15$ mA |
| | Reverse current | I_R 0.01 μ A typ., 5 μ A max. | $V_R = 4$ V |
| | Peak emission wavelength | λ_P 700 nm typ. | $I_F = 10$ mA |
| Detector | Light current | I_L 0.3 μ A min., 8.0 μ A max. | $I_F = 5$ mA, $V_{CE} = 10$ V White paper with a reflection ratio of 90%, $d = 4$ mm (see note) |
| | Dark current | I_D 2 nA typ., 250 nA max. | $V_{CE} = 10$ V, 0 lx |
| | Leakage current | I_{LEAK} --- | --- |
| | Collector-Emitter saturated voltage | $V_{CE (sat)}$ | --- |
| | Peak spectral sensitivity wavelength | λ_P | 750 nm typ. |
| Rising time | t_r | 180 μ s typ. | $V_{CC} = 5$ V, $R_L = 100 \Omega$, $I_L = 1$ mA |
| Falling time | t_f | 60 μ s typ. | $V_{CC} = 5$ V, $R_L = 100 \Omega$, $I_L = 1$ mA |

Note: The letter "d" indicates the distance between the top surface of the sensor and the sensing object.

■ Engineering Data

Forward Current vs. Collector Dissipation Temperature Rating

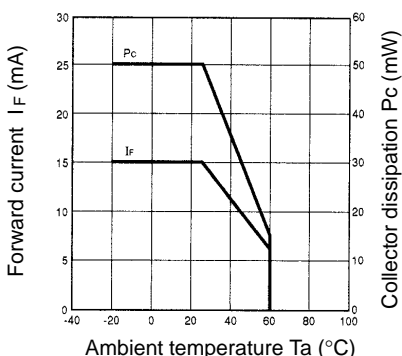

Light Current vs. Forward Current Characteristics (Typical)

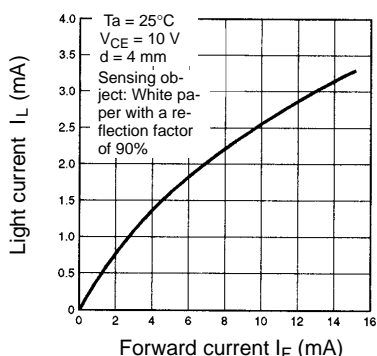

Light Current vs. Collector-Emitter Voltage Characteristics (Typical)

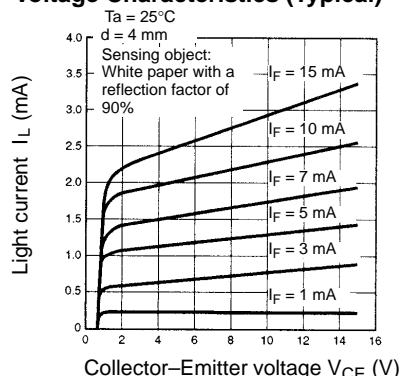

Relative Light Current vs. Ambient Temperature Characteristics (Typical)

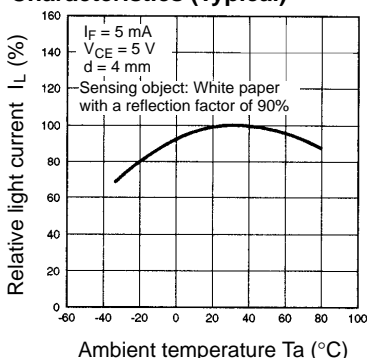

Dark Current vs. Ambient Temperature Characteristics (Typical)

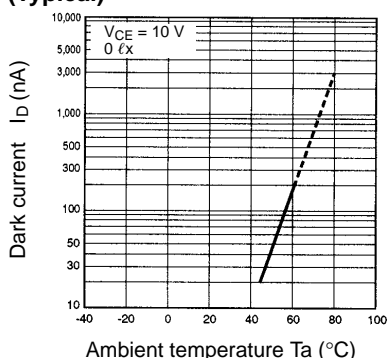

Response Time vs. Load Resistance Characteristics (Typical)

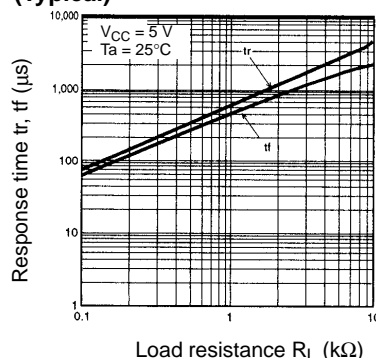

Sensing Distance Characteristics (Typical)

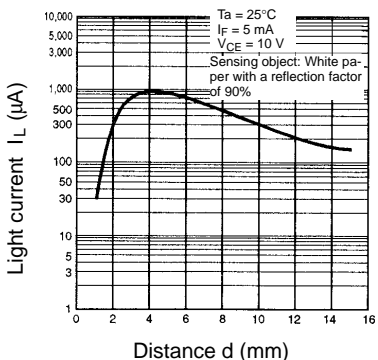

Sensing Position Characteristics (Typical)

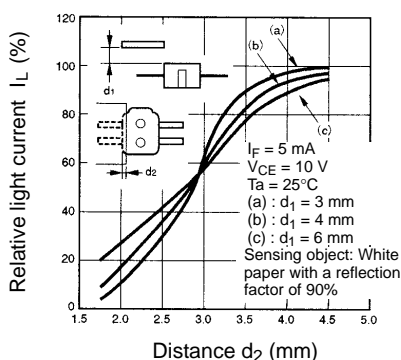

Sensing Angle Characteristics (Typical)

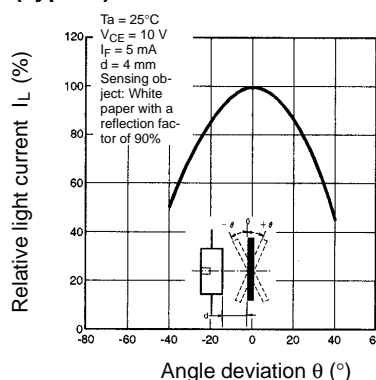

Response Time Measurement Circuit

