

APPROVED: _____
 DATE: _____ TITLE: _____

Rev	AWO #	Description	Date	Appr
-		RELEASED	11/2/21	

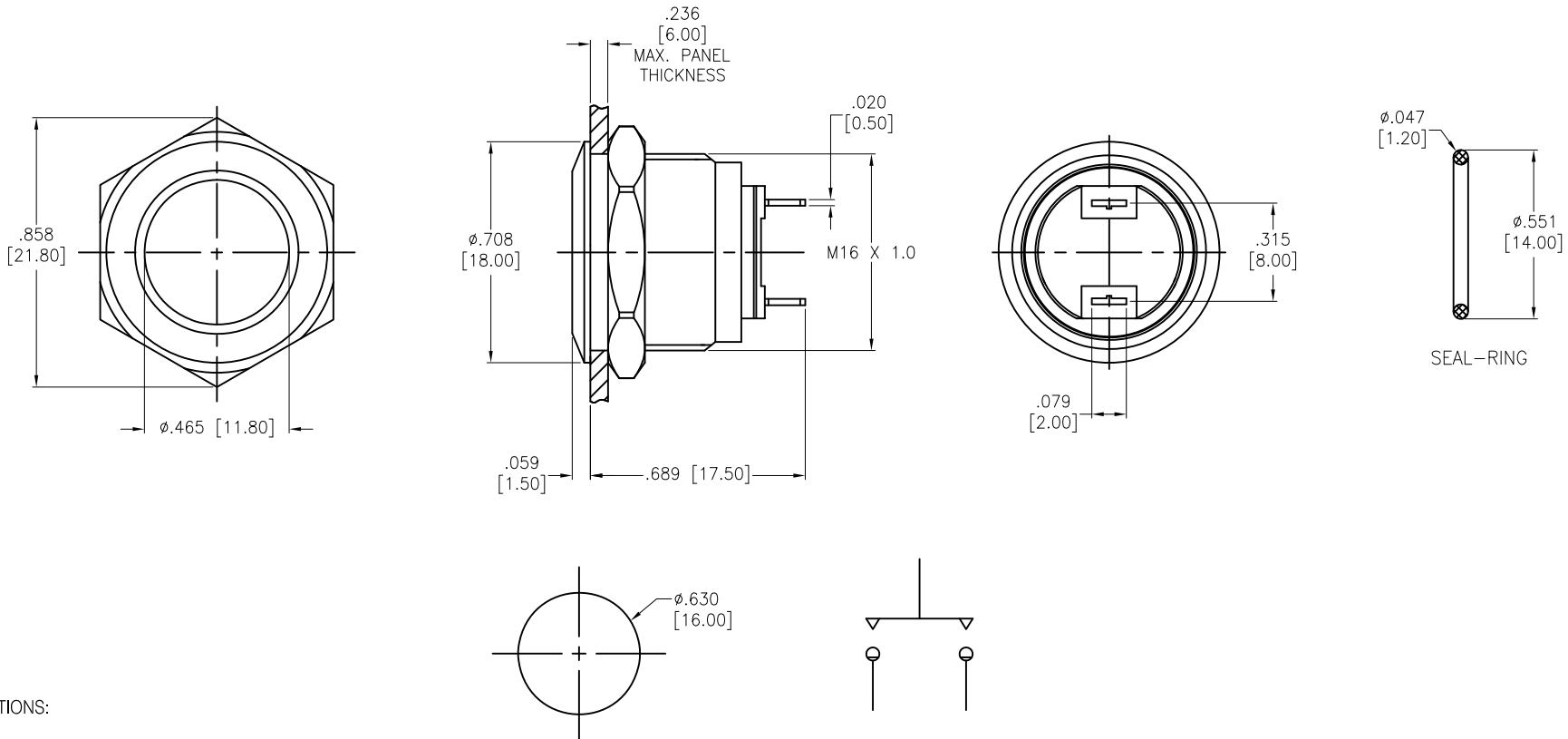

SPECIFICATIONS:

Material:
 Bushing&Button: Stainless steel, Varnish polished
 Base: PA
 Contact Material: Silver Alloy, (2.0x0.5mm)

Electrical:
 Switch Rating: 0.5A @ 220V AC
 Contact resistance: 50 m Ω max initial.
 Insulation resistance: 1000M ohms min.
 Dielectric withstanding voltage: 1,500V, RMS 50Hz, 1min
 Electrical Life: 50,000 cycles min.

Mechanical:
 Operating Force: 4N
 Nut Torque: 0.6Nm max.
 Temperature Rating:
 Operating temperature: -25°C to +55°C

Environmental:
 IP65 Front Panel Protection
 Lead free, RoHS compliant



RECOMMENDED
 PANEL CUT-OUT

CIRCUIT DIAGRAM
 (SPST) OFF-MOM

UNLESS OTHERWISE SPECIFIED ALL DIMENSIONS
 ARE INCHES [MM]. TOLERANCES: EXCEPT AS NOTED

INCHES		HOLES	
.X	$\pm .10$	ϕ .X	$\pm .10$
.XX	$\pm .020$	ϕ .XX	$\pm .015$
.XXX	$\pm .015$	ϕ .XXX	$\pm .010$



909 Rahway Avenue,
 Union, NJ 07083
 Phone: 908-687-5000
 Fax: 908-687-5710

DRAWN	WX	11/2/21
CHECKED	RC	11/2/21
APPROVED		

TITLE SWITCH, ANTI-VANDAL, PUSH BUTTON, SPST,
 OFF-MOM, 16mm, FLAT BUTTON, MOMENTARY

THIS DRAWING CONTAINS INFORMATION THAT IS PROPRIETARY
 AND SHOULD NOT BE USED WITHOUT PRIOR WRITTEN
 PERMISSION FROM ADAM TECH

SIZE	PART NO.	REV.
X	SW-PB7-01B32BFM	-
REF: S00198T	SCALE: NTS	SHEET 1 OF 1