

QUAD HIGH-VOLTAGE PORT CONTROLLER FOR POE AND POE+ PSEs

Features

- Each Si3452/3 high-voltage port controller supports four PSE power interfaces
- Programmable current limits for PoE (15.4 W), PoE+ (30 W), and proprietary systems (up to 40 W) per port
- I²C interface requires no external MCU for easy, low-cost management of 4 to 48 ports by the host system
- Unique high-voltage component integration simplifies design, lowers power dissipation, minimizes external BOM, and reduces PCB footprint
 - Internal low-R_{ON} power FETs with current-sense circuitry
 - Integrated transient voltage surge suppressors
 - DC disconnect (Si3453) or proprietary dV/dt disconnect (Si3452) sensing methods
- Programmable architecture supports IEEE 802.3af (PoE) and IEEE 802.3at (PoE+) PSEs
 - Programmable current limits for PoE (350 mA) and PoE+ (600 mA), and custom limits to 850 mA
 - Per-port current and voltage monitoring for sophisticated power management and control
 - Power policing mode
 - Robust multi-point detection
 - Supports 1-Event and 2-Event classification algorithms
- Comprehensive, robust, fault-protection circuitry
 - Supply under-voltage lockout (UVLO)
 - Output current limit and short-circuit protection
 - Foldback current limiting
 - Dual-threshold thermal overload protection
 - Fault source reporting for intelligent port management
- Extended commercial (–10 to 85 °C) and industrial (–40 to 85 °C) operating temperatures
- Compact, 6×6 mm², 40-pin QFN RoHS-compliant package

Applications

- Power over Ethernet Endpoint switches and Midspans for IEEE Std 802.3af and 802.3at
- Supports high power PDs, such as:
 - Pan/Tilt/Zoom security cameras
 - 802.11n WAPs
 - Multi-band, multi-radio WAPs
- Security and RFID systems
- Industrial automation systems
- Networked audio
- IP Phone Systems and iPBXs
- Metropolitan area networked WAPs, cameras, and sensors
- WiMAX ASN/BTS and CPE/ODU systems

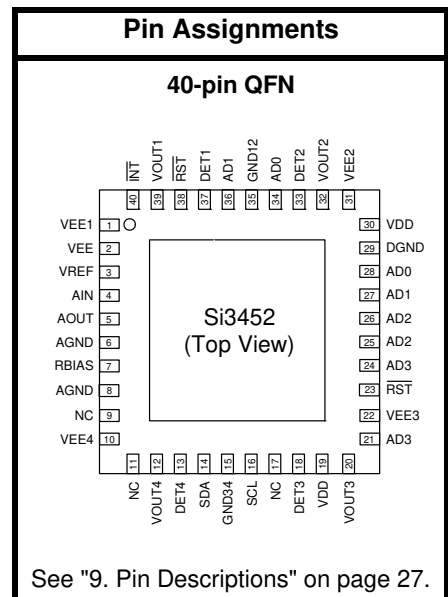

Si3452/3

Description

When connected directly to the host system or configured in Auto mode, each Si3452/3 high-voltage port controller provides all of the critical circuitry and sophisticated power measurement functionality for the high-voltage interfaces of four complete PSE ports. The Si3452/3 fully integrates robust, low- R_{ON} ($0.3\ \Omega$ typical) power MOSFET switches, low-power dissipation current sensing circuitry, and transient voltage surge suppression devices.

The on-chip current sense circuitry and power MOSFETs provide programmable scaling of current limits to match either PoE (350 mA, 15.4 W), PoE+ (600 mA, 30 W), and extended (800 mA, 40 W) power requirements on a per-port basis. Designed for use in Endpoint PSE (e.g., Ethernet switches) or Midspan PSE (e.g., inline power injectors) applications, each Si3452/3 also performs the IEEE-required powered device (PD) detection, classification, and disconnect functionality.

The flexible architecture enables powered device disconnect detection using either dc disconnect (Si3453) or Silicon Laboratories' proprietary dV/dt disconnect (Si3452) sensing algorithm. dV/dt disconnect is an alternative to dc disconnect that requires no additional BOM components, does not dissipate extra device power, and fully interoperates with all powered devices. Also provided are multi-point detection algorithms and per-port current and voltage monitoring.

Intelligent protection circuitry includes power supply under-voltage lockout (UVLO), port output current limiting and short-circuit protection, thermal overload sensing and port shutdown, and transient voltage surge-suppressors capable of protecting the Si3452/3 from a variety of harsh surge events seen on the RJ-45 interface.

To maximize system design flexibility and minimize cost, each Si3452/3 connects directly to a system host controller through an I²C serial interface, eliminating the need for an external MCU. The Si3452/3 can be set to one of 12 unique addresses, allowing control of up to 48 ports on a single I²C bus.

Functional Block Diagram

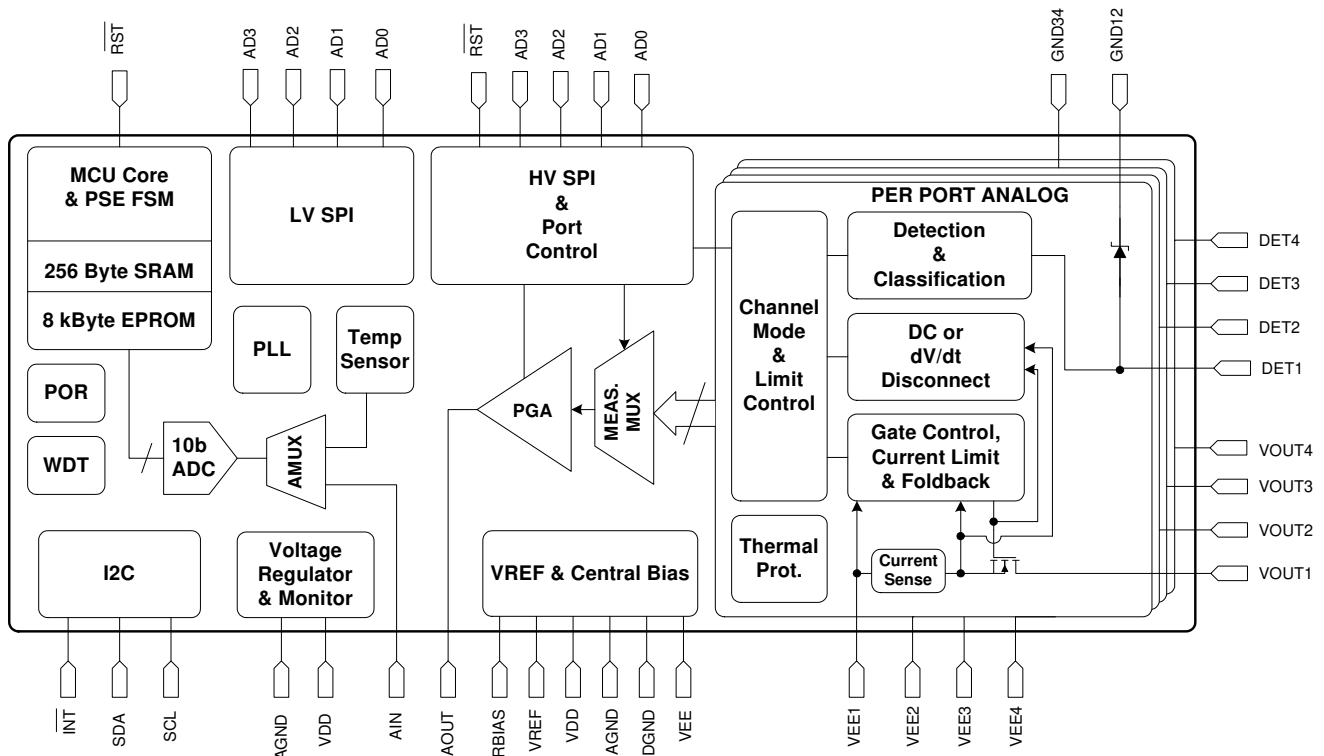

TABLE OF CONTENTS

<u>Section</u>	<u>Page</u>
1. Electrical Specifications	4
2. PSE System-Level Diagrams	11
3. PSE Application Diagrams	11
4. Functional Description	12
4.1. Detection	12
4.2. Classification	13
4.3. Port Turn-On and Power FETs	13
4.4. Disconnect Detection	14
4.5. Transient Voltage Surge Suppression	14
4.6. Temperature Sense	14
4.7. Port Measurement and Monitoring	14
4.8. SMBus/I ² C Interface Description	15
5. Register Interface	17
5.1. Interrupt (Registers 0x00–0x01)	17
5.2. Port Event (Registers 0x02–0x05)	17
5.3. Port Status (Registers 0x06–0x09)	17
5.4. Port Configuration (Registers 0x0A–0x11)	18
5.5. Command and Return Registers (Registers 0x12–0x1C)	19
5.6. Device Status Register (0x1D)	19
6. Operational Notes	24
6.1. Port Turn On	24
6.2. Changing the Interrupt Mask	24
6.3. Port Voltage and Current Measurements	24
7. PCB Layout Guidelines	25
8. Firmware Release Notes	26
8.1. Initialization Time	26
8.2. Current Limiting in 2x Power Mode	26
8.3. I ² C Address ACK	26
9. Pin Descriptions	27
10. Package Outline: 40-Pin QFN	30
11. Recommended PCB Footprint	31
12. Ordering Guide	33
12.1. Evaluation Kits and Reference Designs	33
13. Device Marking Diagram	34
Document Change List	35
Contact Information	36

1. Electrical Specifications

Unless noted otherwise, specifications apply over the operating temperature range with VDD = +3.3 V and VEE = -48 V relative to GND.

VDD pins should be electrically shorted. AGND pins, DGND, GND12, and GND34 should be electrically shorted ("GND"). VEE, VEE1, VEE2, VEE3, and VEE4 should be electrically shorted ("VEE").

VPort for any port is measured from GND to the respective VOUTn.

Table 1. Absolute Maximum Ratings¹

Type	Description	Rating	Unit
Supply voltages	VEE to GND	-62 to +0.3	V
	VDD to GND	-0.3 to +3.6	V
	VDD1 to VDD2	-0.3 to +0.3	V
	Any VEE to any other VEE	-0.3 to +0.3	V
	Any GND to any other GND	-0.3 to +0.3	V
Voltage on digital pins	SDA, SCL, ADn, $\overline{\text{RST}}$, $\overline{\text{INT}}$	(GND - 0.3) to (VDD + 0.3)	V
Voltage on analog pins	VREF, AIN, AOUT, RBIAS, OSC	(GND - 0.3) to (VDD + 0.3)	V
	VOUTn, DETn	(VEE - 0.3) to (GND + 0.3)	V
DETn peak currents during surge events ²		±5	A
Maximum continuous power dissipation ³		1.2	W
Maximum junction temperature		125	°C
Ambient storage temperature		-55 to 150	°C
Lead temperature (soldering, 10 seconds maximum)		260	°C
Notes:			
<ol style="list-style-type: none"> Functional operation should be restricted to those conditions specified in Table 2. Functional operation or specification compliance is not implied at these conditions. Stresses beyond those listed in absolute maximum ratings may cause permanent damage to the device. See IEEE Std 802.3-2005, clause 33.4, for a description of surge events. If all ports are on with 600 mA load, the power dissipation is <1.2 W. At 85 °C ambient with the expected 32 °C/W thermal impedance, the junction temperature would be 123.4 °C, which is within the 125 °C maximum rating. 			

Table 2. Recommended Operating Conditions

Description	Symbol	Test Conditions	Min	Typ	Max	Unit
Ambient operating temperature	T_A	“-GM” part numbers	-10	—	85	°C
		“-IM” part numbers	-40	—	85	
Thermal impedance*	θ_{JA}	No airflow	—	32	—	°C/W
		1 m/s airflow	—	28	—	
Power Supply Voltages						
V_{EE} supply voltage	V_{EE}	For IEEE 802.3af (15.4 W) apps.	-57	-48	-45	V
		For IEEE 802.3at (30 W) apps.	-57	-54	-51	
V_{DD} supply voltage	V_{DD}		3.0	3.3	3.6	V
Power Supply Currents						
V_{EE} supply current	I_{EE}	All ports on, excluding load current.	—	3.7	6.0	mA
		All ports in shutdown mode	—	1	2	
V_{DD} supply current	I_{DD}		—	8	14	mA
*Note: Modeled with six parts evenly spaced on a 30 x 120 mm ² , four-layer board with 25 thermal vias to a Vneg plane on the back.						

Table 3. UVLO, and Reset Specifications

Description	Symbol	Test Conditions	Min	Typ	Max	Unit
V_{DD} reset threshold	V_{RST}		—	2.2	—	V
V_{DD} power-on ramp*		Ramp from 0 V to 3.0 V	—	—	1	ms
\overline{RST} input high voltage			$0.7 \times V_{DD}$	—	—	V
\overline{RST} input low voltage			—	—	0.8	V
\overline{RST} input leakage		$\overline{RST} = 0$ V	—	—	40	μA
Reset time delay	T_{RSTDLY}	Time between end of reset and beginning of normal operation	—	—	100	msec
Reset assertion time	T_{RST}	\overline{RST} low time to generate system reset	15	—	—	μs
V_{EE} monitor accuracy	V_{EEMON}	Measured V_{EE} relative to actual V_{EE} for V_{EE} (-44 to -57 V)	-4	—	4	%
V_{EE} UVLO threshold	V_{UVLO}	Point at which VEE UVLO is declared.	-38	-36	—	V
		VEE going negative	—	-33	-31	
*Note: If VDD ramp time is slower than 1 msec, hold the reset pins low until VDD is above 3.0 V to insure proper reset operation.						

Table 4. Detection Specifications

Description	Symbol	Test Conditions	Min	Typ	Max	Unit
Detection current limit	I_{LIM_DET}	Measured with DETn shorted to GND	—	3	5	mA
Detection voltage, when $R_{DET} = 25\text{ k}\Omega$	V_{DET1} V_{DET2} V_{DET3}		— -10.0 —	-4.0 -8.0 -4.0	-2.8 — -2.8	V
Detection slew rate			—	—	0.1	V/ μ s
Detection probe duration	T_{PROBE}		10	—	30	ms
Detection probe cycle time	T_{DET}		—	—	500	ms
Minimum valid signature resistance	R_{DET_MIN}		15	—	19	k Ω
Maximum valid signature resistance	R_{DET_MAX}		26.5	—	33	k Ω
Resistance at which open circuit is declared	R_{OPEN}		100	—	400	k Ω
Resistance at which short circuit is declared	R_{SHORT}		150	—	400	Ω
Valid detect capacitance	C_{DET_VALID}		—	—	150	nF
Invalid detect capacitance	$C_{DET_INVALID}$		10	—	—	μ F

Table 5. Classification Specifications

Description	Symbol	Test Conditions	Min	Typ	Max	Unit
Class event voltage	V_{CLASS}	$0\text{ mA} < I_{Port} < 45\text{ mA}$	-20.5	—	-15.5	V
Mark event voltage	V_{MARK}	$0\text{ mA} < I_{Port} < 5\text{ mA}$	-7	—	-10	V
Classification current limit	I_{LIM_CLASS}	Measured with DETn shorted to GND	51	—	100	mA
Classification current regions		Class 0 Class 1 Class 2 Class 3 Class 4 Overcurrent	0 8 16 25 35 51	— — — — — —	5 13 21 31 45 —	mA
Classification delay	T_{CLASS_DLY}	Time from end of valid detect cycle to classification begin	—	5	—	ms
Classification event time	T_{CLE}	Width of valid V_{CLASS} probe for 1-Event or 2-Event classification	10	—	30	ms
Mark event time	T_{ME}	Width of mark between classification events	—	8	—	ms

Table 6. VOUT Drive and Power-on Specifications

Description	Symbol	Test Conditions	Min	Typ	Max	Unit
Max output resistance (port on)	R_{ON}	$I_{Port} \leq 720 \text{ mA}$	—	0.3	0.6	Ω
Current limit	I_{LIM}	1x mode, $V_{port} = V_{EE} + 1 \text{ V}$	400	425	450	mA
Change in current limit	ΔI_{LIM}	1x mode, $V_{port} = V_{EE} + 1 \text{ V}$ to -30 V^1	-2	—	2	%
Current limit	I_{LIM}	2x mode, $V_{port} = V_{EE} + 1 \text{ V}$	800	860	920	mA
Change in current limit	ΔI_{LIM}	2x mode, $V_{port} = V_{EE} + 1 \text{ V}$ to -40 V^2	-2	—	2	%
Current limit	I_{LIM}	1x mode or 2x mode, $V_{port} = -10 \text{ V}$	60	—	—	mA
Overload current threshold	I_{CUT}	Class 0 Class 1 (class policing enabled) ³ Class 2 (class policing enabled) ³ Class 3 Class 4 ⁴	350 91 160 350 600	— — — — —	— — — — —	mA
Over current time limit ⁵	$T_{OVL D}$	Load current $\geq I_{CUT}$ or I_{LIM}	50	—	75	ms
VOUTn turn-on slew	T_{RISE}	10% to 90%	15	70	—	μs
Power turn on timing	T_{PON}	Time from end of valid detect to power on	—	—	400	ms
VOUTn leakage current	I_{OUT_LEAK}	Port in shutdown	—	—	10	μA

Notes:

- $T_J > 25 \text{ }^\circ\text{C}$, -35 V over the full temperature range.
- 1x mode current limit is enforced during the 60 ms T_{START} time.
- In auto mode, class policing is automatically enabled. In manual mode, I_{CUT} must be programmed manually. See "5.4. Port Configuration (Registers 0x0A–0x11)" on page 18 for more information.
- 600 mA is consistent with the IEEE 802.3at draft standard. I_{CUT} is user-programmable in 3.2 mA increments to over 800 mA for non-standard applications.
- For 2x mode and extreme overload or short-circuit events, $T_{OVL D}$ will dynamically decrease to prevent excessive FET heating. This is consistent with the 802.3at draft.

Table 7. DC- and dV/dt Disconnect Specifications

Description	Symbol	Test Conditions	Min	Typ	Max	Unit
Load current to prevent disconnect	I_{ON}		10	—	—	mA
Load current to guarantee disconnect	I_{OFF}	dc disconnect	—	—	5	mA
		dV/dt disconnect	—	—	2	mA
Disconnect delay	T_{DCDV_DLY}	Time from I_{OFF} load current to port turn off	300	—	400	ms

Table 8. Port Measurement and Monitoring Specifications

Description	Symbol	Test Conditions	Min	Typ	Max	Unit
Port current measurement offset	I_{OFFSET}	$20 \text{ mA} \leq I_{\text{PORT}} \leq I_{\text{CUT}}$. For final I_{PORT} reading, add offset to % of reading tolerance.	-5	—	5	mA
Port current measurement tolerance	%TOL		-4	—	4	%

Table 9. SMBus (I²C) Electrical Specifications

VDD = 3.0 to 3.6 V

Description	Symbol	Test Conditions	Min	Typ	Max	Unit
Input low voltage	V_{IL}	SCL, SDA pins $T_j \leq -10 \text{ }^\circ\text{C}$	—	—	0.85	V
		SCL, SDA pins over full temp range			0.8	
Input high voltage	V_{IH}	SCL, SDA pins	2.2	—	—	V
Output low voltage	V_{OL}	SCL, SDA pins, driving $\leq 8.5 \text{ mA}$	—	—	0.6	V
Input leakage current	I_{L}	SCL, SDA pins	—	—	40	μA

Table 10. Address Pin Electrical Specifications*

VDD = 3.0 to 3.6 V

Description	Symbol	Test Conditions	Min	Typ	Max	Unit
Input low voltage	V_{IL}	AD0, AD1, AD2, AD3 pins	—	—	0.8	V
Input high voltage	V_{IH}	AD0, AD1, AD2, AD3 pins	$0.7 \times V_{\text{DD}}$	—	—	V
Input leakage current	$I_{\text{H}}, I_{\text{L}}$	AD0, AD1, AD2, AD3 pins	-10	—	10	μA

***Note:** At power-up, these pins are logic inputs. A 10 k Ω pull up or pull down resistor is used for address selection. After address recognition, the pins are used for internal communications.

Table 11. SMBus (I²C) Timing Specifications (see Figure 1)

VDD = 3.0 to 3.6 V

Description	Symbol	Test Conditions	Min	Typ	Max	Unit
Serial bus clock frequency	f_{SCL}		0	—	400	kHz
SCL high time	t_{SKH}		600	—	—	ns
SCL low time	t_{SKL}		1.3	—	—	μ s
SCL, SDA rise time	t_{R_SCL}		20	—	300	ns
SCL, SDA fall time	t_{F_SCL}		20	—	150	ns
Bus free time	t_{BUF}	Between START and STOP conditions.	1.3	—	—	μ s
Start hold time	t_{STH}	Between START and first low SCL.	600	—	—	ns
Start setup time	t_{STS}	Between SCL high and START condition.	600	—	—	ns
Stop setup time	t_{SPS}	Between SCL high and STOP condition.	600	—	—	ns
Data hold time	t_{DH}		200	—	—	ns
Data setup time	t_{DS}		200	—	—	ns
Time from hardware or software reset until start of I ² C traffic	t_{RESET}	Reset to start condition	—	—	100	ms
Delay from event to INT pin low or from clear-on-read to INT pin high	t_{INT}		—	—	5	ms

Notes:

1. Not production tested (guaranteed by design).
2. All timing references measured at V_{IL} and V_{IH} .
3. The Si3452/3 will stretch (pull down on) SCK during the ACK time period if required. The maximum SCL stretching is 10 μ sec; so, SCL only needs to be bidirectional for I²C bus speeds over 50 kHz.

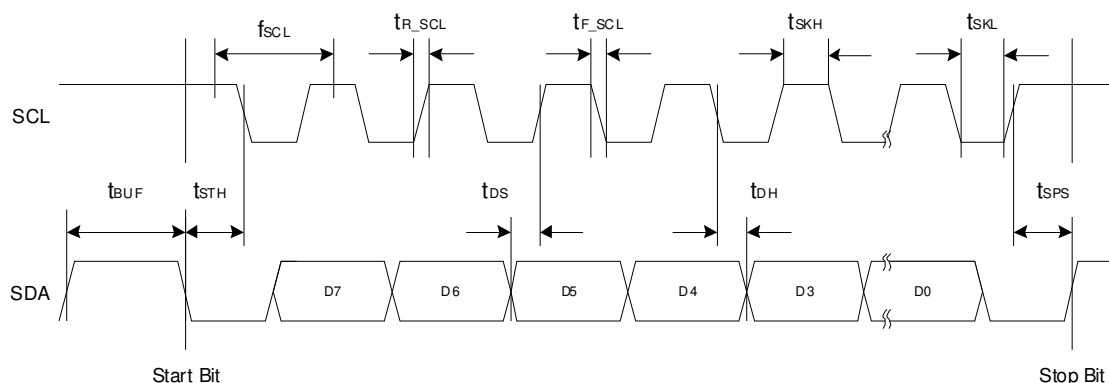

Figure 1. I²C Timing DiagramTable 12. Interrupt ($\overline{\text{INT}}$) Specifications

Description	Symbol	Test Conditions	Min	Typ	Max	Unit
Output low voltage	V _{OL}	$\overline{\text{INT}}$ pin driving ≤ 8.5 mA	—	—	0.6	V

Table 13. Input Voltage Reference Specifications

Description	Symbol	Test Conditions	Min	Typ	Max	Unit
Nominal VREF input			—	1.1	—	V
Reference tolerance			—	—	1	%
VREF loading		Input current	-10	—	+10	μA

2. PSE System-Level Diagrams

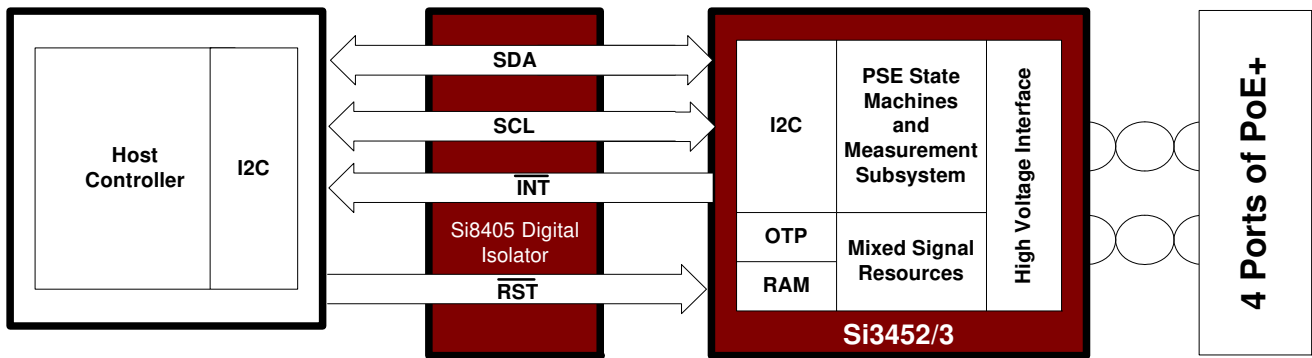

Figure 2. 4-Port System with Direct Host Connection

3. PSE Application Diagrams

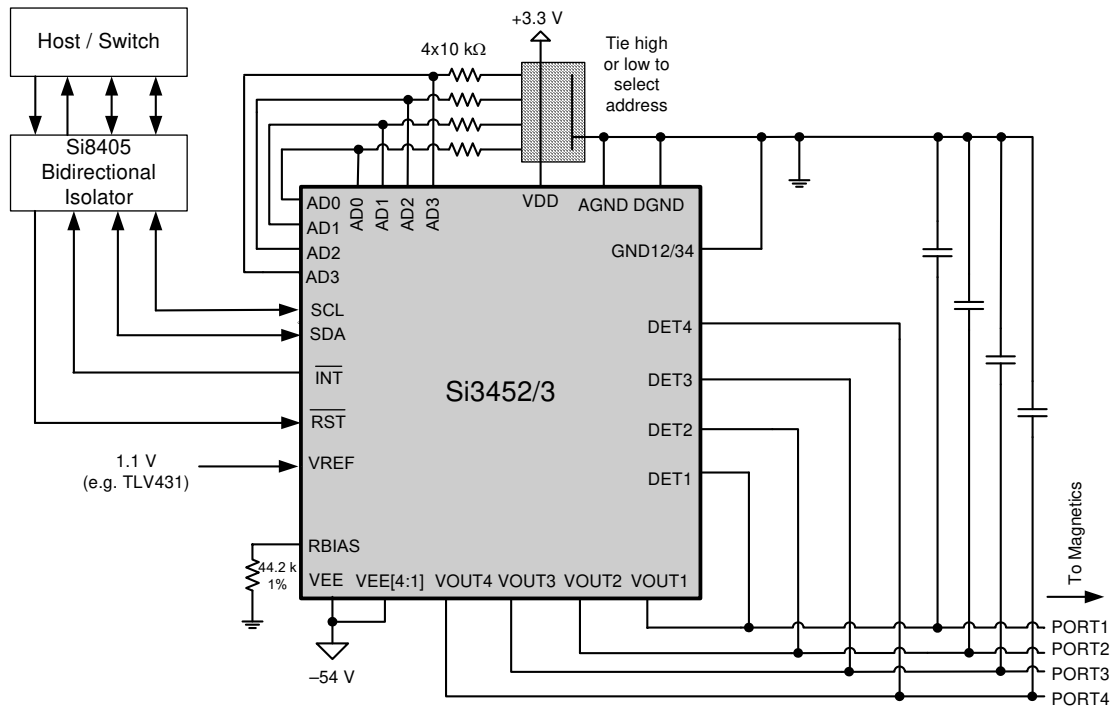

Figure 3. 4-Port Application Diagram Using DC- or dV/dt Disconnect and I²C Host Interface

4. Functional Description

Integrating four independent, high-voltage PSE port interfaces, the Si3452/3 high-voltage port controller enables an extremely flexible solution for virtually any PoE or PoE+ PSE application. The Si3452/3 provides all of the high-voltage Power over Ethernet PSE functions.

Each port of the Si3452/3 integrates all high-voltage PSE controller functions needed for a quad-port PoE design, including the power MOSFET, efficient current-sensing circuitry, transient voltage surge suppressor, and multiple detect and disconnect circuits. When the dc disconnect or dV/dt disconnect sensing methods are selected, the external BOM is typically only a single filter capacitor on each high-voltage port.

When a PD device has been properly detected and classified, the port is powered by a -54 V nominal supply with continuous monitoring of voltage and current for feedback to the host system.

In addition to the required IEEE features, the Si3452/3 includes many additional features:

- Per port current / voltage monitoring and measurement
- Support for 1-Event and 2-Event classification algorithms
- Start up in shutdown or auto mode
- Alternative A (typically used for endpoint systems) or Alternative B (typically used for midspan systems) detection timing

4.1. Detection

The Si3452/3 has per-port signature detection that satisfies the IEEE Std 802.3™-2005 specifications. However, by utilizing a 3-point voltage-forced detection method, the Si3452/3 yields robust recognition of valid and invalid powered device (PD) signatures, properly identifying signatures often mischaracterized by other detection techniques.

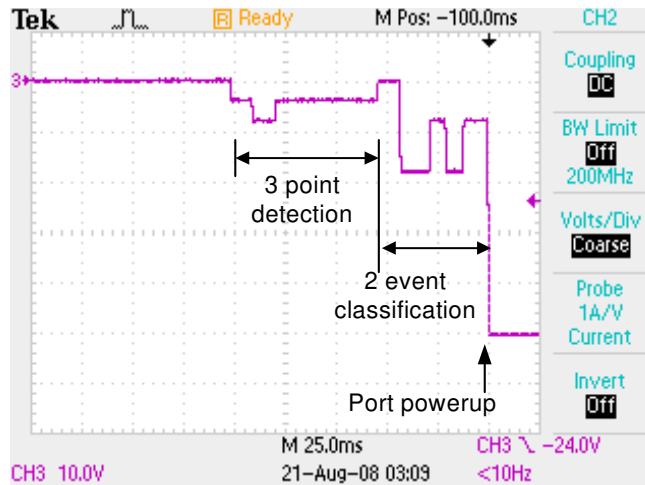

**Figure 4. PSE Sequencing
(3-Point Detection followed by 2-Event Classification and Powerup)
Vport Relative to GND**

The detection circuitry performs the function of setting the output voltage on any channel to the proper value for detection or classification and then measuring the resulting line current.

A typical detection cycle consists of applying 4 V, then 8 V, and back to 4 V, with the current limit set to 3 mA. The current is measured after an appropriate settling time. For a valid PD, the detection signature must be compliant with the detection voltage both increasing and decreasing.

4.2. Classification

Following a successful PD detection, the classification phase will be automatically initiated in all operational modes. During this phase, a single measurement will be made at 18 V to determine how much power the PD device will draw under maximum loads per the IEEE 802.3af and 802.3at standards. The current limit during this test mode is 60 mA nominal.

The Si3452/3 supports 1-Event and 2-Event classification. When operating in PoE (≤ 15.4 W) mode, 1-Event classification is used. Operation in PoE+ (> 15.4 W) mode results in 2-Event classification probes. The 1-Event classification is compliant to IEEE standard 802.3-2005. 2-Event classification is compliant to draft IEEE P802.3at.

4.3. Port Turn-On and Power FETs

The FET is turned on with a gate drive that results in a very low-noise turn-on waveform with a slew rate of less than 1 V/ μ sec (See Figure 5).

The power FET switch on each port has been sized to have a typical ON resistance of approximately 0.3 Ω . The shunt resistor for current measurement has also been set to 0.1 Ω . Including interconnection and process variation, the total resistance to VEE for a port that is on is 0.6 Ω (max). This limits the maximum power dissipation per channel to < 250 mW when the operating current is 600 mA, the maximum current allowed by the IEEE 802.3at PoE+ standard.

The FET has a programmable operating current limit. Each channel can be set to support output currents of 400 mA or 800 mA minimum.

In addition to the normal current limit, there is a short circuit current shutdown approximately 25% greater than the nominal current limit. If there is a transient current surge where the current ramps up faster than the programmed current limit can respond, the gate drive voltage is clamped immediately to VEE. The clamp is enabled for at least 10 μ s, which allows the normal current circuitry to respond.

Another important protection feature is foldback current limiting. When VOUT is near VEE, the current limit is at maximum. As the VDS of the driver switch increases (and VOUT is closer to ground), the current limit goes to its lowest level. The amount of the foldback current is scaled proportionally with the programmed current limit.

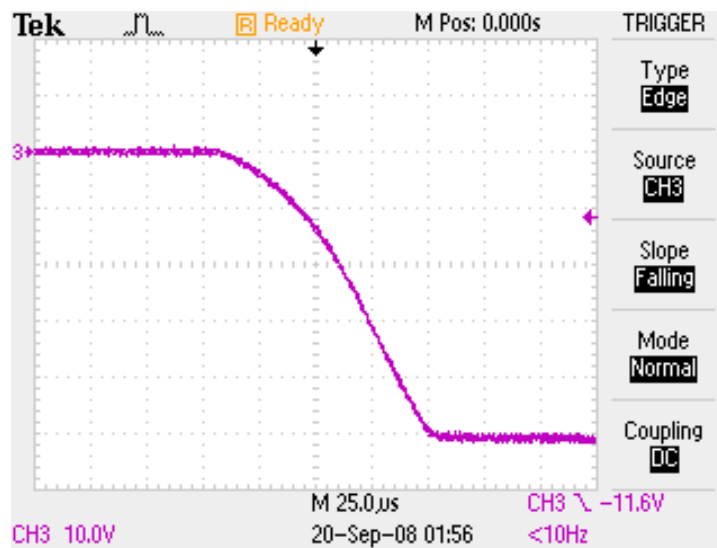

Figure 5. Turn-On Waveform—Vport Relative to GND

4.4. Disconnect Detection

4.4.1. dV/dt Disconnect (Si3452)

The dV/dt disconnect function can be used to detect a disconnected device without using dc disconnect or ac disconnect.

In dV/dt disconnect mode, the FET current limit is switched to 7.5 mA. If the voltage across the FET increases, a load is assumed to be present, and the FET current limit is automatically switched back to its pre-selected value. If, after 350 ms, the FET voltage has not increased, there is no load present, and the FET is turned off.

In addition to operating in a manner functionally distinct from DC disconnect, dV/dt disconnect requires no additional external components and fully interoperates with all powered device DC Maintain Power Signatures. For more information, see "AN399: dV/dt Disconnect and the IEEE 802.3 PoE Standard".

4.4.2. DC Disconnect (Si3453)

The port current is continuously monitored by the Si3452/3. The Si3452/3 can dynamically change the measurement scale to achieve accuracy over a wide range of currents.

As defined in the IEEE 802.3 PoE standard, the PSE should disconnect if the port current is less than a nominal 7.5 mA for more than 350 ms.

4.5. Transient Voltage Surge Suppression

The Si3452/3 features robust on-chip surge protectors on each port; this is an industry first. This unique protection circuitry acts as an active device that can withstand lightning-induced transients as well as large ESD transient events. When the port voltage exceeds its protection limit and the current reaches a triggering threshold, current is shunted from the port to the ground pins.

Internal circuitry is provided to protect the line outputs from externally-coupled fault currents. These are transient currents of up to 5 A peak.

The operation of the protection circuits depends on the operating mode of the channel switch and the direction of the fault current. The clamping operation is performed on the detect pin.

The switch itself will also be protected by the current limit. If the transient lasts long enough to heat up the die, then the temperature sense circuit will shut off the switch, and all the fault current will flow through the clamp diode.

4.6. Temperature Sense

A temperature sense signal is used in conjunction with the current limit status signals from the gate drive blocks. Any channel that is generating excess heat is assumed to be operating in current limit mode, with both high voltage drop and high current.

If the port is in PoE mode, an overload will generally not result in thermal shutdown before the 60 ms I_{CUT} period. If the port is in PoE+ mode, an overload may cause the port to shut down prior to the 60 ms I_{CUT} period. In either case, the event is reported as I_{CUT} . The faster shutdown in PoE+ mode is consistent with and specifically allowed by the 802.3at draft and provides much more robust overload protection than is possible with external FETs.

In addition, there is a thermal shutdown if the package temperature exceeds 120 °C. If this threshold is reached, all output drivers are turned off and detection modes are disabled. This secondary threshold limit guards against the possibility that the overheating is not caused by a driver operating in current limit.

4.7. Port Measurement and Monitoring

VEE monitoring in conjunction with port current monitoring allows measurement of port power. Port power monitoring, dynamic power allocation via LLDP*, and port power policing allow efficient power supply sizing.

The Si3452/3 is factory-calibrated and temperature-compensated for the following measurements:

- Port current measurement. These measurements are auto-ranged and scaled to a 16 bit number at 100 μ A per bit. Port current accuracy is $\pm 4\% \pm 2$ mA.
- V_{EE} is measured with a scale of 64 V. The measurement is reported as a 16-bit number scaled at 1 mV per bit. V_{EE} measurement accuracy is $\pm 4\%$ over the valid V_{EE} range.

***Note:** LLDP = Link Layer Discovery Protocol. Refer to IEEE 802.3at (draft) and IEEE 802.1AB for more information.

4.8. SMBus/I²C Interface Description

The I²C interface is a two-wire, bidirectional serial bus. The I²C is compliant with the System Management Bus Specification (SMBus), version 1.1 and compatible with the I²C serial bus. Reads and writes to the interface by the system controller are byte-oriented with the I²C interface autonomously controlling the serial transfer of the data. A method of extending the clock-low duration is available to accommodate devices with different speed capabilities on the same bus. The I²C provides control of SDA (serial data), SCL (serial clock) generation and synchronization, arbitration logic, and START/STOP control and generation.

A typical I²C transaction consists of a START condition followed by an address byte (Bits7–1: 7-bit slave address; Bit0: R/W direction bit), one or more bytes of data, and a STOP condition. Each byte that is received (by a master or slave) must be acknowledged (ACK) with a low SDA during a high SCL (see Figure 6). If the receiving device does not ACK, the transmitting device will read a NACK (not acknowledge), which is a high SDA during a high SCL.

The direction bit (R/W) occupies the least-significant bit position of the address byte. The direction bit is set to logic 1 to indicate a "READ" operation and cleared to logic 0 to indicate a "WRITE" operation. All transactions are initiated by a master, with one or more addressed slave devices as the target. The master generates the START condition and then transmits the slave address and direction bit. If the transaction is a WRITE operation from the master to the slave, the master transmits the data one byte at a time, waiting for an ACK from the slave at the end of each byte.

For READ operations, the slave transmits the data waiting for an ACK from the master at the end of each byte. At the end of the data transfer, the master generates a STOP condition to terminate the transaction and free the bus. Figure 6 illustrates a typical SMBus/I²C transaction.

Silicon Laboratories recommends the use of bidirectional digital isolators, such as the Si840x, to isolate the I²C communications interface between the Si3452/3 high-voltage port controllers and the system host controller.

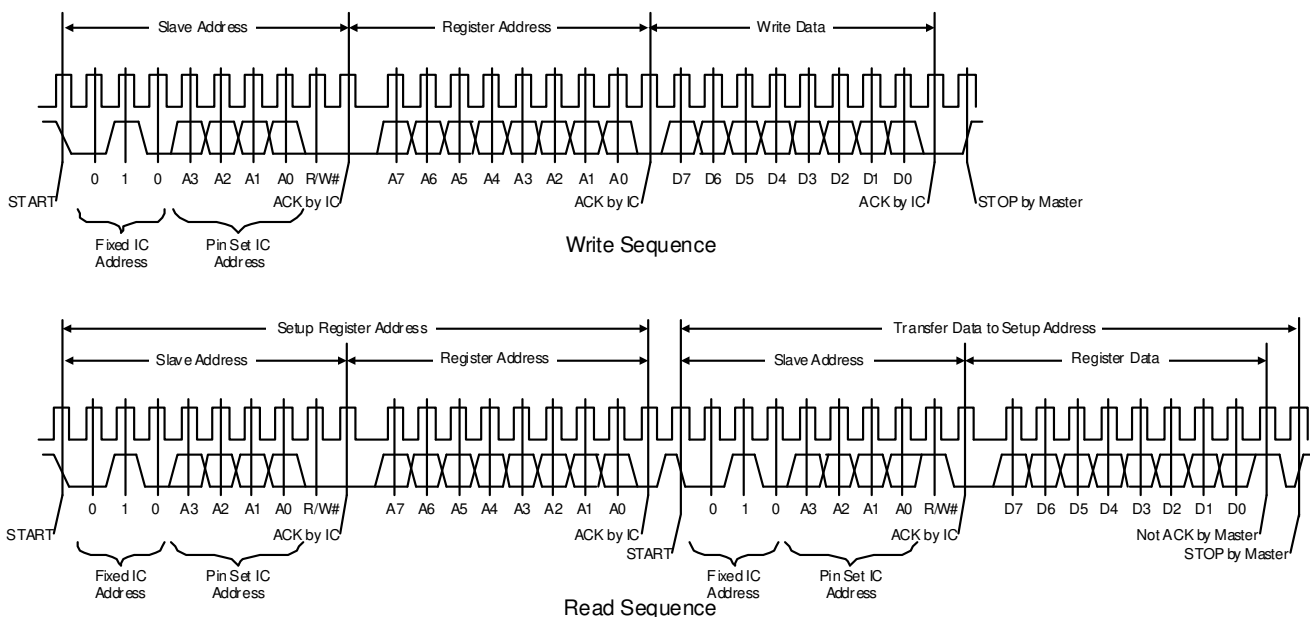

Figure 6. Typical I²C Bus Transactions

The Si3452 does not support the alert response address (ARA) protocol. Polling is used to determine which controller is interrupting in an interrupt-driven system.

4.8.1. Address Pins

Table 14. Address Pin Assignment

Pin #	Pin Name
21	AD3
24	AD3
25	AD2
26	AD2
27	AD1
28	AD0
34	AD0
36	AD1

Pins with the same name must be externally connected and then tied high or low via a weak (10 kΩ) pull up or pull down to establish the device address at power up. The Si3452/3 powers up in either Auto mode or Shutdown mode depending on the ordering part number. For more information, see "12. Ordering Guide" on page 33.

4.8.2. Address Format

The address byte of the I²C communication protocol has the following format:

Table 15. I²C Address Byte Protocol

Bit 7	Bit 6	Bit 5	Bit 4	Bit 3	Bit 2	Bit 1	Bit 0
0	1	0	AD3	AD2	AD1	AD0	R/W

AD3, AD2, AD1, and AD0 are the pin-selected address bits (pull up = 1; pull down = 0). For the R/W bit, see Figure 6. The device will also respond to the global address, 0x30. The Si3452 does not support bus arbitration; so, a global read command will generally give an invalid result. Global writes can be useful for initialization as well as for shutting down low-priority ports. Table 16 lists the valid device addresses:

Table 16. Address Selection

AD3	AD2	AD1	AD0	Address	Valid
0	0	0	0	0x20	Y
0	0	0	1	0x21	Y
0	0	1	0	—	N
0	0	1	1	—	N
0	1	0	0	0x24	Y
0	1	0	1	0x25	Y
0	1	1	0	—	N
0	1	1	1	—	N
1	0	0	0	0x28	Y
1	0	0	1	0x29	Y
1	0	1	0	0x2A	Y
1	0	1	1	0x2B	Y
1	1	0	0	0x2C	Y

Table 16. Address Selection (Continued)

AD3	AD2	AD1	AD0	Address	Valid
1	1	0	1	0x2D	Y
1	1	1	0	0x2E	Y
1	1	1	1	0x2F	Y

5. Register Interface

The registers types are described in the following sections.

5.1. Interrupt (Registers 0x00–0x01)

An interrupt ($\overline{\text{INT}}$ pin low) is generated if any bit of the Interrupt register (register 0x00) is true. The Interrupt register contains the information about which port is generating the interrupt or if the interrupt is due to a global event.

The port interrupt is generated by the port event register masked by the interrupt mask register.

Port event = (t_{START} Event AND t_{START} mask) OR (t_{LCUT} Event AND t_{LCUT} mask) OR (Rgood_CLS_event AND Rgood_CLS_mask) OR (DET_COMPL_EVENT AND DET_COMPL_MASK) OR (PwrGood_change AND Pwrgood_change_MASK) OR (Penable_event AND Penable_mask)

The device event bit of the interrupt register is set if there is a change in the V_{EE} or temperature status in register 0x1D. Reading 0x1D clears the event.

5.2. Port Event (Registers 0x02–0x05)

This register contains bits that become true if the event has occurred. The registers are Clear On Read (COR) so that reading these registers will clear the $\overline{\text{INT}}$ pin if the $\overline{\text{INT}}$ pin is being held low due to a port event.

“ t_{START} ” is an event bit indicating an overload occurred for all but 5 msec of the initial 60 msec start up time.

“ t_{LCUT} ” is an event bit indicating that an overload condition has existed for greater than 60 msec after the first 60 msec. t_{LCUT} has a 16:1 up/down counter so that, if the overload is present at less than a 6.66% cycle, the port will not shut down. Overload is defined as $I > I_{\text{CUT}}$ or port voltage not within 2 V of V_{EE} . The port is turned off on this event. A t_{LCUT} event is also generated if the port is shutdown due to an overload or due to the protection clamp turning on. If the port is set to auto mode, it will attempt to re-power after >750 msec if there is a good detection signature.

“Rgood CLS” indicates classification has been completed. Classification is only attempted after an Rgood; so, if this bit is set, it indicates that detection gave an Rgood and classification is complete.

“DET compl” indicates the completion of a detection cycle. Normally, this bit will be masked. The DET complete bit is used for legacy detection via modified link pulses. If the link pulse is returned indicating a PD is present, then, normally, a detection is done, and the port is powered only if the result is not a short. In some cases, it may be desirable to deny power to a port where an overload has been detected until the port is unplugged. In this case, the Ropen result will be used to indicate the port has been unplugged and detection and classification can resume.

“Disconnect event” indicates a disconnect has occurred. DC power was removed due to the dV/dt or DC disconnect. Overload conditions or loss of V_{EE} turns off ports but does not generate a disconnect event.

“Pgood” indicates the port has been turned on and did not shut down during the Tstart time.

“Penable” indicates a port has been turned on.

5.3. Port Status (Registers 0x06–0x09)

These registers specify the port status. They are read-only registers.

“Pwr good” indicates that the port has been turned on and the port voltage is within 2 V of V_{EE} .

“Pwr Enable” indicates the port has been turned on.

The three class status bits indicate the last classification result for that port. If a classification has not been done or if the port is shut down with no new classification result, the class status is reported as unknown.

The three detect status bits indicate the last detection result for that port. If a detection has not been done or if the port is shut down with no new detection result, the detection status is reported as unknown.

5.4. Port Configuration (Registers 0x0A–0x11)

These registers indicate the port configuration; they are read/write registers.

The port priority bit is set if the port is not high priority. Low-priority ports are shut down when the shutdown low-priority ports command is issued.

The “PoE+” bit specifies the dc current limit at either 425 mA or 850 mA nominal*.

***Note:** The PoE+ mode should be set correctly according to the electrical design of the PSE circuit (transformer and conductor current carrying capacity). The PoE+ port mode can safely be changed prior to port turn-on, but changes after port turn-on do not have an immediate effect and are not recommended.

“Disconnect enable” must be set for power to be removed if there is a disconnect. The disconnect type (based on dc disconnect or Silicon Labs’ proprietary dV/dt disconnect) is determined by the ordering part number.

“Port mode” is set according to Table 17.

Table 17. Port Mode Selection

Port Mode Setting B1, B0	Mode	Description
00b	Shutdown	The power is shut down with no detection pulses. A command to manually power the port is ignored.
01b	Manual	The port can be powered by the manual power command.
10b	Semiauto	Detection is done and classification is done for Rgood, but the port does not power.
11b	Auto	Detection classification and port powering are all automatic with no host intervention required. I_{CUT} and I_{LIM} are automatically set according to the PoE+ mode and classification result.

I_{CUT} is the nominal current level at which the port will automatically power down if I_{CUT} is exceeded for 60 msec. It can be set with 3.2 mA resolution. The accuracy of current measurement is approximately 5%; so, I_{CUT} is normally set 7% higher than the supported current level. I_{CUT} is automatically set based on the classification result and PoE+ mode. The automatically-set I_{CUT} level is appropriate for a 45 V minimum system power supply for classes 0–3 and for a 51 V minimum power supply for PoE+ mode. This feature is classification policing.

If the Si3452/3 is in the semi-auto mode, I_{CUT} will not be updated according to the classification result. This means that if it is desired to set I_{CUT} at port turn-on, this should be done before the port is turned on.

Once a port is turned on, I_{CUT} can be changed dynamically. It is often undesirable to use a low value of I_{CUT} during port turn-on because inrush can trigger the I_{CUT} event. For this reason, it is normal to allow the port to turn on with the automatic I_{CUT} setting and then later change this value after port current has stabilized and also if the PD and PSE have negotiated for a different I_{CUT} value based on the PoE L2 power negotiation protocol (LLDP).

The Si3452/3 supports 2-Event classification as defined in the IEEE 802.3at draft. 2-event classification is an alternative to L2 power management where the PSE advertises it is capable of PoE powering by generating two classification pulses. 2-Event classification is only supported for auto mode. If the Si3452/3 is in auto mode and the first event classification result is Class 4, the mark, second event, and second mark are performed. Power is applied only if the second event is also Class 4. If the second event is not Class 4, the classification error is reported, and the port will not power. If the port is in manual mode, classification is done prior to turning on the port.

5.5. Command and Return Registers (Registers 0x12–0x1C)

The global command register enables manual port turn-on or turn-off, chip reset, port reset, and measurement of port current and V_{EE} . Register 0x12 is a Write only register. See Table 24 on page 23 for a list of all available commands.

If the command results in a numerical return value, that value is stored in the measurement registers, which are read-only. Each of the five possible measurements results in a 2 byte return value, and that value is stored in a unique register. V_{EE} is encoded in mV units; so, the full scale is 65.535 V. I_{port} is encoded in 100 μ A units; so, the full scale is 6.5535 A.

The output data is updated by the proper command register write operation (see Table 23). This means that the numerical value of the port current or V_{EE} voltage in the measurement register will be the value at the time the command was issued. If the port turns off due to an overload or disconnect, the port current register contents will not be set to zero. If a command to read port current is issued and the port is off, the return value will be zero.

5.6. Device Status Register (0x1D)

The device event bits are listed in Table 18.

Table 18. Device Status Bits

Bit	Description
B6 - OverTemp	The Si3452/3 has per-port thermal shutdown sensors as well a global thermal shutdown at a slightly higher temperature. The global thermal shutdown bit of the device event register is set if this occurs.
B5 - V_{EE} UVLO	V_{EE} UVLO. The part is put in its reset state if V_{EE} is not in a valid range.

The Device status register is RO. The V_{EE} , UVLO, and overtemp bits reflect the device status. They are set if V_{EE} or temperature is out of range and reset if the V_{EE} or temperature is in range. Bit 6 of the Interrupt register is set if there is a change in the overtemp status (bit 6 of 0x1D), and bit 5 of the Interrupt register is set if there is a change in the V_{EE} UVLO status (bit 5 of 0x1D). Reading register 0x1D clears these bits of the Interrupt register but does not clear the device status register.

In addition, bit B0 indicates whether or not detection back-off is used. For PSEs that are wired as Alternative B (power on the spare pair—typically used for midspans), the time between detection pulses is increased to slightly over two seconds to avoid interference with Alternative A (power on the data pair—typically used for endpoints). Bit B0 can be toggled using the 0x10 command code.

Table 19. Si3452/3 Register Map

Address	Register Name	Type	B7	B6	B5	B4	B3	B2	B1	B0	POWER_UP
Interrupts											
0x00	Interrupt Reg 1	RO		Overtemp change	V _{EE} UVLO change		Port 4 event	Port 3 event	Port 2 event	Port 1 event	0x00
0x01	Interrupt Mask 1	RW	Device status mask	t _{START} mask	t _{CUT} mask	Rgood CLS mask	DET compl mask	Disconnect mask	PwrGood mask	PwrEn mask	0x85
Port Events											
0x02	Port 1 Events	COR		t _{START} Event	t _{CUT} Event	Rgood CLS	DET compl	Disconnect Ev	PwrGood Change	PwrEn Change	0x00
0x03	Port 2 Events	COR		t _{START} Event	t _{CUT} Event	Rgood CLS	DET compl	Disconnect Ev	PwrGood Change	PwrEn Change	0x00
0x04	Port 3 Events	COR		t _{START} Event	t _{CUT} Event	Rgood CLS	DET compl	Disconnect Ev	PwrGood Change	PwrEn Change	0x00
0x05	Port 4 Events	COR		t _{START} Event	t _{CUT} Event	Rgood CLS	DET compl	Disconnect Ev	PwrGood Change	PwrEn Change	0x00
Status											
0x06	Port 1 Status	RO	PwrGood Status	PwrEnable Status	CLS Stat B2	CLS Stat B1	CLS Stat B0	DET Stat B2	DET Stat B1	DET Stat B0	0x00
0x07	Port 2 Status	RO	PwrGood Status	PwrEnable Status	CLS Stat B2	CLS Stat B1	CLS Stat B0	DET Stat B2	DET Stat B1	DET Stat B0	0x00
0x08	Port 3 Status	RO	PwrGood Status	PwrEnable Status	CLS Stat B2	CLS Stat B1	CLS Stat B0	DET Stat B2	DET Stat B1	DET Stat B0	0x00
0x09	Port 4 Status	RO	PwrGood Status	PwrEnable Status	CLS Stat B2	CLS Stat B1	CLS Stat B0	DET Stat B2	DET Stat B1	DET Stat B0	0x00
Configuration											
0x0A	Port 1 Config	RW				Port priority	PoE+	Discon En	Port Mode B1	Port Mode B0	00000100b
0x0B	Port 2 Config	RW				Port priority	PoE+	Discon En	Port Mode B1	Port Mode B0	00000100b
0x0C	Port 3 Config	RW				Port priority	PoE+	Discon En	Port Mode B1	Port Mode B0	00000100b
0x0D	Port 4 Config	RW				Port priority	PoE+	Discon En	Port Mode B1	Port Mode B0	00000100b
0x0E	Port 1 I _{CUT}	RW	B7	B6	B5	B4	B3	B2	B1	B0	0x75
0x0F	Port 2 I _{CUT}	RW	B7	B6	B5	B4	B3	B2	B1	B0	0x75
0x10	Port 3 I _{CUT}	RW	B7	B6	B5	B4	B3	B2	B1	B0	0x75
0x11	Port 4 I _{CUT}	RW	B7	B6	B5	B4	B3	B2	B1	B0	0x75

Table 19. Si3452/3 Register Map (Continued)

Address	Register Name	Type	B7	B6	B5	B4	B3	B2	B1	B0	POWER_UP
Global Device											
0x12	Command Register	WO								CMD Param B0	0x00
0x13	V _{EE} MSB	RO									0x00
0x14	V _{EE} LSB	RO									0x00
0x15	Current P1 MSB	RO									0x00
0x16	Current P1 LSB	RO									0x00
0x17	Current P2 MSB	RO									0x00
0x18	Current P2 LSB	RO									0x00
0x19	Current P3 MSB	RO									0x00
0x1A	Current P3 LSB	RO									0x00
0x1B	Current P4 MSB	RO									0x00
0x1C	Current P4 LSB	RO									0x00
0x1D	Device Status	RO		OverTemp	V _{EE} UVLO					Alternative B Timing	0x00
Revision											
0x60	Hardware Revision	RO									
0x61	Firmware Revision	RO									
0x62	Firmware Revision	RO									
0x63	Firmware Revision	RO									

Table 20. Si3452/3 Detect Encoding

Value	Condition
000b	Unknown
001b	Short
010b	Reserved
011b	Rlow
100b	Good
101b	Rhigh
110b	Ropen
111b	Reserved

Table 21. Si3452/3 Class Encoding

Value	Condition
000b	Unknown
001b	Class 1
010b	Class 2
011b	Class 3
100b	Class 4
101b	Probes Not Equal
110b	Class 0
111b	Class Overload

Table 22. Si3452/3 Port Mode Encoding

Value	Condition
00b	Shutdown
01b	Manual
10b	Semiauto
11b	Auto

Table 23. Si3452/3 Port Configuration

PoE+ bit	Class	Auto Mode Setting of I _{CUT} Register	I _{CUT} Nominal	Ilim Nominal*
0 or 1 don't care	1	0x1E	97 mA	425 mA
0 or 1 don't care	2	0x35	170 mA	425 mA
0 or 1 don't care	0/3	0x75	375 mA	425 mA
0	4	0x75	375 mA	425 mA
1	4	0xC9	640 mA	850 mA

*Note: During initial port turn-on (T_{START} time of 60 msec), the current limit is set to 425 mA, even in PoE+ mode.

Table 24. Si3452/3 Command Codes

Command	CMD Register	[B5..B2]	[B1..B0] Command Parameter	2 Byte Return Value
Power on port	0x04 port no	0001b	2 bit port number ¹	—
Power off port	0x08 port no	0010b	2 bit port number	—
Reset port	0x0C port no	0011b	2 bit port number	—
Toggle detection back-off timing ²	0x10	0100b	NA	—
Reset chip	0x14	0101b	NA	—
Get V _{EE}	0x18	0110b	NA	V _{EE} in mV units
Read port current	0x1C port no	0111b	2 bit port number	Port current in 100 μA units
Shut down low-priority ports	0x20	1000b	NA	—

Notes:

1. Port 1 has 2 bit port number 0x00; port 2 is 0x01, etc.
2. This command toggles bit 0 of Register 0x1D. When bit zero is set, the detection back-off of 2 seconds is implemented (alternative B or “midspan” mode).

6. Operational Notes

6.1. Port Turn On

If the port is turned on by putting it in auto mode, the Si3452/3 will take care of all specified timing, and it will take care of the two-event classification if the first event result is Class 4 and PoE+ mode is enabled. However, if automatic mode operation is not desired after port turn-on, the port should be set to semi-auto or manual mode once it has powered. In automatic mode, I_{CUT} is set according to the classification result.

The port turn-on command is used to turn on a port in semi-auto or manual mode. If the port is turned on in semi-auto mode, turn-on is delayed until the next detection and classification. If the detection or classification result is not valid, the port will not power. If the classification is Class 4 and PoE+ mode is enabled, a 2-event classification is given. I_{CUT} setting is not automatic for port turn-on in semi-auto or manual mode.

If the port is turned on by putting it in manual mode, the normal sequence is to start with the port in semi-auto mode and interrupt on a classification complete, which indicates that there is a valid PD signature and that a classification result is available. Based on the classification result, the host can make a decision to apply power or not. The IEEE standard requires that a port be powered within 400 msec of a valid detect complete. It is also desirable to power the port prior to the start of the next detection pulse, which can occur in as little as 300 msec. Therefore, it is recommended that ports be powered in under 250 msec from the class complete interrupt when using the manual mode turn-on command.

Using manual mode turn-on, detection is not done prior to port turn on, but classification is always performed just prior to port turn on. Ports are turned on in manual mode regardless of the classification result. 2-event classification is performed if the first event result is Class 4 and the port is enabled for PoE+ mode. The manual mode classification step does not generate a classification complete flag because it is assumed that the classification was already done in semi-auto mode and the host has already made the decision to grant power.

During the initial 60 msec (T_{start}) time of port turn-on, 1x current limit and $I_{CUT} = 375$ mA (nominal) is enforced. After T_{start} , if the port is not overloaded, Pgood is set to true, and I_{CUT} and 1x or 2x current limit will follow the I²C register settings. In auto mode, the I²C registers are set according to the classification result, but, if desired, they can be overwritten after Pgood becomes true. After T_{start} , 2x current limit is always allowed if PoE+ mode is enabled.

6.2. Changing the Interrupt Mask

The INT register and \overline{INT} pin are always synchronized. However, there can be up to a 5 msec delay between an event that causes or clears an interrupt and the update of the register and pin.

Thus, if the INT mask register is changed to clear an interrupt or to block an interrupt source, there can be up to a 5 msec delay between the change of the INT mask register and the resultant change in the INT register and \overline{INT} pin.

Generally, use of the mask register to clear interrupts is not recommended; it is better to clear an interrupt by reading the appropriate COR register.

6.3. Port Voltage and Current Measurements

Port current voltage and current are reported as of the time the measurement command is written to register 0x12. Spikes of current or other momentary current changes are not filtered. It may be desirable to add a ~1 second averaging filter to reported current when using port current information for power management decisions.

7. PCB Layout Guidelines

Following are some PCB layout considerations. See also "12.1. Evaluation Kits and Reference Designs" on page 33 for reference design information. Please visit the Silicon Labs technical support web page at <https://www.silabs.com/support/pages/contacttechnicalsupport.aspx> and register to request support for your design, particularly if you are not closely following the recommended reference design.

Due to the high current of up to 800 mA per port, the following board layout guidelines apply. In addition, contact Silicon Laboratories for access to complete PSE reference design databases including recommended layouts.

The VEE1, VEE2, VEE3, and VEE4 pins can carry up to 800 mA and are connected to a V_{EE} bus. The V_{EE} bus for a 24 port PCB layout can thus carry as much as 20 A current. With 2 oz. copper on an outer layer, a bus of 0.4 inches is needed. For an inner layer, this increases to a 1 inch wide bus. Use of large or multiple vias is required for properly supporting the 800 mA per channel operating current. The VEE pin does not carry high current and can be connected directly to the bus as well. The best practice is to devote an entire inner layer for V_{EE} power routing.

Similarly, GND1/2 and GND3/4 pins can carry up to 1.6 A per pin, and the GND return bus should be at least as wide as the V_{EE} bus described above. The best practice is to devote an entire inner layer for ground power routing. The ground power plane does not generally have a high frequency content (other than external faults); so, it is generally acceptable to use the ground power plane as a ground signal plane and tie AGND and GND12, GND34 to this plane as well.

The VOUTn pins carry up to 800 mA dc and up to 5 A in faults; so, a 20 mil trace with wide or multiple vias is also recommended. The VDETn pins also carry fault current; so, this pin connection to VOUTn needs to use 20 mil traces and wide or multiple vias where needed.

The VDD currents are not large; so, it is acceptable to route the VDD nodes on one of the outer layers.

If care is taken to avoid disruption of the high current paths, VDD can be globally routed on one of the power planes and then locally routed on an inner or outer layer.

To avoid coupling between surge events and logic signals, it is recommended that VOUTn traces be routed on the side opposite the I²C interface pins.

The thermal pad of the Si3452/3 is connected to VEE. At full IEEE 802.3at current of 600 mA on each port, the dissipation of the Si3452/3 is up to 1.2 W; so, multiple vias are required to conduct the heat from the thermal pad to the VEE plane. As many as 36 small vias provide the best thermal conduction.

8. Firmware Release Notes

Devices marked with firmware revision 01 (see "13. Device Marking Diagram" on page 34) have the firmware revision registers set as 0x61 = 0x00; 0x62 = 0x02, and 0x63 = 0x4F (0.2.79).

The following are known issues, all of which may be addressed with a future firmware revision:

8.1. Initialization Time

Issue: The initialization time after a reset or power up is 65 msec.

Impact: None - informational.

Workaround: Wait 100 msec after a reset before beginning I²C transactions.

8.2. Current Limiting in 2x Power Mode

Issue: In 2x current limiting mode, current is limited at the 1x value during the T_{start} time as required by the 802.3at draft standard. For the last 0.4 msec of the 60 msec T_{start} time, the current limit is increased to the 2x value.

Impact: This would only be seen if the PD applies a continuous overload during the inrush time. The slight extra spike of current is less than 1 msec; so, it falls within the allowed current limit transient response.

Workaround: None

8.3. I²C Address ACK

Issue: Very rarely, the Si3452 may not ACK the I²C address byte.

Impact: This is allowed in the I²C specification.

Workaround: Retransmit the address byte if there is an ACK failure.

9. Pin Descriptions

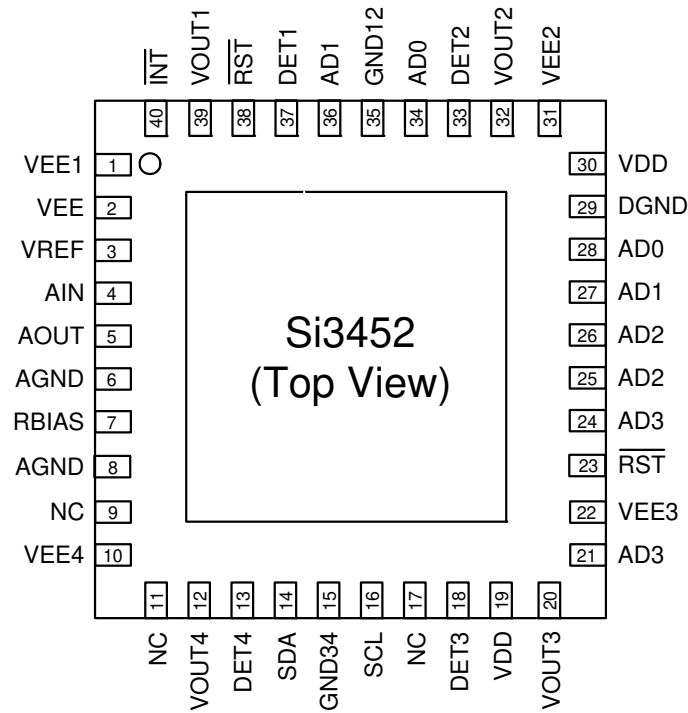

Table 25. Si3452/3 Pin Descriptions

Pin #	Name	Type	Description
1	VEE1	Supply	Driver 1 VEE supply. Short to VEE, VEE2/3/4.
2	VEE	Supply	Global PoE (–48 V nom.) or PoE+ (–54 V nom.) supply. Short to VEE1/2/3/4.
3	VREF	Analog input	1.1 V nom. voltage reference from reference generator (for example, TLV431 or power management unit).
4	AIN	Analog input	Measurement data converter input. Short to AOUT.
5	AOUT	Analog output	Measurement multiplexer subsystem output. Short to AIN.
6	AGND	Ground	Analog ground reference. Short to AGND pin 8, GND12/34, DGND.
7	RBIAS	Analog input	External 44.2 kΩ (±1%) resistor to ground sets internal bias currents.
8	AGND	Ground	Analog ground reference. Short to AGND pin 6, GND12/34, DGND.
9	NC	No connect	Do not connect (float).
10	VEE4	Supply	Driver 4 VEE supply. Short to VEE, VEE1/2/3.
11	NC	No connect	Do not connect (float).
12	VOUT4	Analog I/O	Port 4 power FET switch output. When on, provides a low impedance path to VEE4.

Table 25. Si3452/3 Pin Descriptions (Continued)

Pin #	Name	Type	Description
13	DET4	Analog I/O	Connection for port 4 detection, classification, and transient surge protection. This pin is tied to VOUT4.
14	SDA	Digital I/O	I ² C data pin
15	GND34	Ground	Ground supply for protection clamps. Short to AGND, GND12, DGND.
16	SCL	Digital I/O	I ² C clock pin
17	NC	No connect	Do not connect (float).
18	DET3	Analog I/O	Connection for port 3 detection and classification. See DET4 for detailed description.
19	VDD	Supply	+3.3V ($\pm 10\%$) isolated supply. Short to VDD pin 30.
20	VOUT3	Analog I/O	Port 3 power FET switch output. When on, provides a low impedance path to VEE3.
21	AD3	Digital I/O	Chip address bit 3 pin, read after reset. Address set with defined resistor dividers. Pin also used for internal communications. Short to AD3 pin 24.
22	VEE3	Supply	Driver 3 VEE supply. Short to VEE, VEE1/2/4.
23	$\overline{\text{RST}}$	Digital input	Active low digital reset. Short to $\overline{\text{RST}}$ pin 38.
24	AD3	Digital I/O	Chip address bit 3 pin, read after reset. Address set with a 10 k Ω pull-up or pull-down resistor. Also used for internal communications. Short to AD3 pin 21.
25	AD2	Digital I/O	Chip address bit 2 pin, read after reset. Address set with a 10 k Ω pull-up or pull-down resistor. Also used for internal communications. Short to AD2 pin 26.
26	AD2	Digital I/O	Chip address bit 2 pin, read after reset. Address set with a 10 k Ω pull-up or pull-down resistor. Also used for internal communications. Short to AD2 pin 25.
27	AD1	Digital I/O	Chip address bit 1 pin, read after reset. Address set with a 10 k Ω pull-up or pull-down resistor. Also used for internal communications. Short to AD1 pin 36.
28	AD0	Digital I/O	Chip address bit 0 pin, read after reset. Address set with a 10 k Ω pull-up or pull-down resistor. Also used for internal communications. Short to AD0 pin 34.
29	DGND	Ground	Digital ground reference. Short to AGND, GND12/34
30	VDD	Supply	+3.3 V isolated supply. Short to VDD pin 19.
31	VEE2	Supply	Driver 2 VEE supply. Short to VEE, VEE1/3/4.
32	VOUT2	Analog I/O	Port 2 power FET switch output. When on, provides a low impedance path to VEE2.
33	DET2	Analog I/O	Connection for port 2 detection and classification. See DET4 for detailed description.
34	AD0	Digital I/O	Chip address bit 0 pin. See description for- and short to AD0 pin 28.
35	GND12	Ground	Ground supply for protection clamps. Short to AGND, GND34, DGND.
36	AD1	Digital I/O	Chip address bit 1 pin. See description for- and short to AD1 pin 27.

Table 25. Si3452/3 Pin Descriptions (Continued)

Pin #	Name	Type	Description
37	DET1	Analog I/O	Connection for port 1 detection and classification. See DET4 for detailed description.
38	$\overline{\text{RST}}$	Digital input	Active low digital reset. Short to $\overline{\text{RST}}$ pin 23.
39	VOUT1	Analog I/O	Port 1 power FET switch output. When on, provides a low impedance path to VEE1.
40	$\overline{\text{INT}}$	Digital output	Active low interrupt output pin.

10. Package Outline: 40-Pin QFN

The Si3452/3 is packaged in an industry-standard, RoHS compliant 6 x 6 mm², 40-pin QFN package.

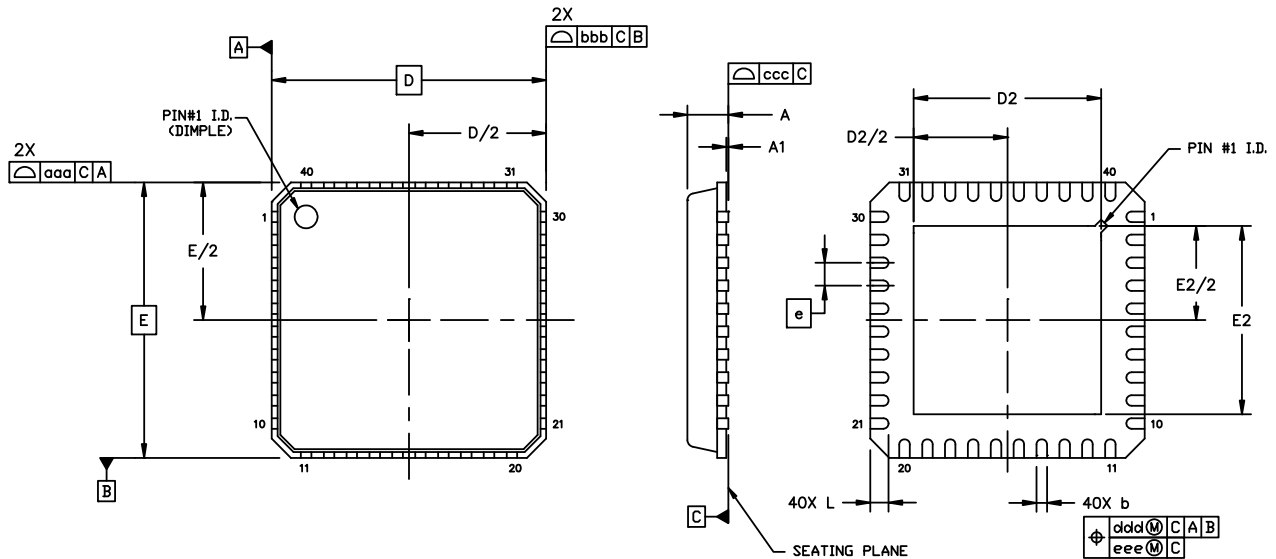

Figure 7. 40-Pin QFN Mechanical Diagram

Table 26. Package Diagram Dimensions

Dimension	Min	Nom	Max
A	0.80	0.85	0.90
A1	0.00	0.02	0.05
b	0.18	0.25	0.30
D	6.00 BSC.		
D2	3.95	4.10	4.25
e	0.50 BSC.		
E	6.00 BSC.		
E2	3.95	4.10	4.25
L	0.30	0.40	0.50
aaa	0.10		
bbb	0.10		
ccc	0.08		
ddd	0.10		
eee	0.05		
Notes:			
1. All dimensions shown are in millimeters (mm) unless otherwise noted.			
2. Dimensioning and Tolerancing per ANSI Y14.5M-1994.			
3. This drawing conforms to JEDEC outline MO-220, Variation VJJD-2			
4. Recommended card reflow profile is per the JEDEC/IPC J-STD-020C specification for Small Body Components.			

11. Recommended PCB Footprint

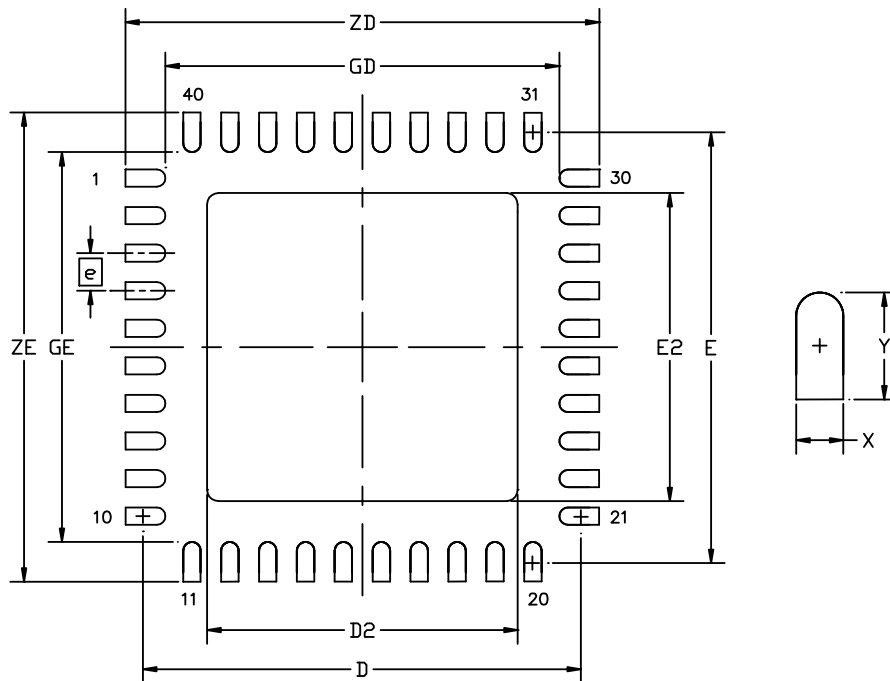

Figure 8. PCB Land Pattern

Table 27. PCB Land Pattern Dimensions

Dimension	Min	Max
e	0.50 BSC	
E	5.42 REF	
D	5.42 REF	
E2	4.00	4.20
D2	4.00	4.20
GE	4.53	—
GD	4.53	—
X	—	0.28
Y	0.89 REF	
ZE	—	6.31

Table 27. PCB Land Pattern Dimensions (Continued)

Dimension	Min	Max
ZD	—	6.31
<p>Notes:</p> <p>General</p> <ol style="list-style-type: none"> All dimensions shown are in millimeters (mm) unless otherwise noted. Dimensioning and Tolerancing is per the ANSI Y14.5M-1994 specification. This Land Pattern Design is based on IPC-SM-782 guidelines. All dimensions shown are at Maximum Material Condition (MMC). Least Material Condition (LMC) is calculated based on a Fabrication Allowance of 0.05 mm. <p>Solder Mask Design</p> <ol style="list-style-type: none"> All metal pads are to be non-solder mask defined (NSMD). Clearance between the solder mask and the metal pad is to be 60 μm minimum, all the way around the pad. <p>Stencil Design</p> <ol style="list-style-type: none"> A stainless steel, laser-cut and electro-polished stencil with trapezoidal walls should be used to assure good solder paste release. The stencil thickness should be 0.125 mm (5 mils). The ratio of stencil aperture to land pad size should be 1:1 for the perimeter pads. A 4x4 array of 0.80 mm square openings on 1.05 mm pitch should be used for the center ground pad. <p>Card Assembly</p> <ol style="list-style-type: none"> A No-Clean, Type-3 solder paste is recommended. The recommended card reflow profile is per the JEDEC/IPC J-STD-020C specification for Small Body Components. 		

12. Ordering Guide

Ordering Part Number ¹	Detect Timing ²	Powerup Mode ^{2,3,4}		Disconnect Method	Firmware Revision	Package ⁵ Temp. Range
Si3452-B01-GM	Alt A	PoE	Shutdown	dV/dt disconnect	0.2.78	-10 to 85 °C ambient
Si3452A-B01-GM	Alt A	PoE (15.4 W)	Auto			
Si3452B-B01-GM	Alt B					
Si3452C-B01-GM	Alt A					
Si3452D-B01-GM	Alt B	PoE+ (30 W)				
Si3453-B01-GM	Alt A	PoE	Shutdown	DC disconnect		
Si3453A-B01-GM	Alt A	PoE (15.4 W)	Auto			
Si3453B-B01-GM	Alt B					
Si3453C-B01-GM	Alt A					
Si3453D-B01-GM	Alt B	PoE+ (30 W)				
Si3452-B01-IM	Alt A	PoE		Shutdown	dV/dt disconnect	0.2.78
Si3452A-B01-IM	Alt A	PoE (15.4 W)	Auto	dV/dt disconnect		

Notes:

1. Add "R" to the end of the ordering part number to denote tape-and-reel option. E.g., Si3452-B01-GMR.
2. For alternative A, power is applied to wire pairs 1,2 and 3,6. For alternative B, power is applied to wire pairs 4,5 and 7,8 (the spare pairs in the case of 10/100 Ethernet). Conventionally, alternative B is used for midspan power injectors. For alternative B, detection is done with over 2 seconds between detection pulses so as to avoid interfering with end-point equipment trying to provide power using alternative A.
3. Devices powering up into shutdown mode are intended for use with a system host that provides run-time configuration or power-management.
4. The maximum PoE or PoE+ power applies to all ports on Auto mode devices.
5. All devices are packaged in RoHS-compliant, 40-pin, 6x6 mm QFN.

12.1. Evaluation Kits and Reference Designs

Part Number	Populated Device	Description	Related Ethernet Chipset	Type
Si3452MS8-KIT	Si3452-B01-GM	PoE+ 8-port Midspan PSE evaluation kit. Includes PC-control interface, PD loads, and cables.	None	Evaluation Kit
Si3452V1-RD*	Si3452-B01-GM	PoE/PoE+ 24-port daughtercard	Vitesse E-StaX (VSC7407)	Reference Design
Si3452V2-RD*	Si3452-B01-GM	PoE+ 8-port Gb-Ethernet switch	Vitesse SparX-G8e (VSC7398)	Reference Design
Si3452M1-RD*	Si3452-B01-GM	PoE/PoE+ 24-port daughtercard	Marvell Prestera-DX, xCAT	Reference Design

***Note:** Due to unique high-voltage and high-power design considerations, Silicon Laboratories recommends that the reference designs be followed very closely for both bill of materials and layout. Please visit the Silicon Labs technical support web page at <https://www.silabs.com/support/pages/contacttechnicalsupport.aspx> and register to request support for your design, particularly if you are not closely following the recommended reference design.

13. Device Marking Diagram

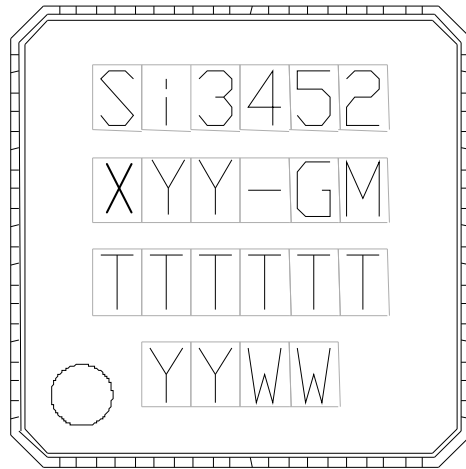

Figure 9. Device Marking Diagram

Table 28. Device Marking Table

Line #	Text Value	Description
1	Si3452	Base part number. This is not the "Ordering Part Number" since it does not contain a specific revision. Refer to "12. Ordering Guide" on page 33. for complete ordering information.
2	XYY	X = Device revision. YY = Firmware revision.
2	GM	Device type. GM = extended commercial temp range; IM = industrial temp range. All devices are RoHS-compliant.
3	TTTTTT	Trace code – assigned by the assembly subcontractor.
4	O	Pin 1 identifier.
	YY	Assembly year
	WW	Assembly week.

DOCUMENT CHANGE LIST

Revision 0.4 to Revision 0.41

- VEE UVLO only. Due to the protection clamp, OVLO is not supported.
- Updated thermal information.
- Removed support for pin-selectable auto mode powerup.
- Changed device status to device event flags in Interrupt register.
- Si3452 is dv/dt disconnect, and Si3457 is DC disconnect.
- Added "6. Operational Notes" on page 24.
- Updated "12. Ordering Guide" on page 33.
- Added "12.1. Evaluation Kits and Reference Designs" on page 33.

Revision 0.41 to Revision 0.42

- Updated Vdd typical current.
- Updated logical levels.
- Clarified port turn on commands
- Made reset timing "TBD". The timing for samples is approximately 50 msec. There is an objective to improve this, but the final reset time has not yet been established.

Revision 0.42 to Revision 0.43

- Added "-IM" industrial temp range devices.
- Adjusted temp specs to accommodate -GM and -IM grades.

Revision 0.43 to Revision 0.44

- Removed I²C ARA and bus arbitration support.
- Added low-priority port function.
- Clarified port turn-on function.
- Added minimum or maximum specs for parameters that had been "TBD" or typical only.

Revision 0.44 to Revision 0.45

- Updated Table 6, "VOUT Drive and Power-on Specifications," on page 7.
- Updated Table 9, "SMBus (I2C) Electrical Specifications," on page 8.
- Updated Figure 3 on page 11.
- Updated "4. Functional Description" on page 12
- Updated "4.4. Disconnect Detection" on page 14.
- Updated "4.5. Transient Voltage Surge Suppression" on page 14.
- Updated "4.8. SMBus/I2C Interface Description" on page 15.

- Added Table 15, "I2C Address Byte Protocol," on page 16.
- Updated "5.1. Interrupt (Registers 0x00–0x01)" on page 17.
- Updated "5.3. Port Status (Registers 0x06–0x09)" on page 17.
- Updated "5.4. Port Configuration (Registers 0x0A–0x11)" on page 18.
- Updated "5.5. Command and Return Registers (Registers 0x12–0x1C)" on page 19.
- Updated Table 18, "Device Status Bits," on page 19.
- Updated Table 19, "Si3452/3 Register Map," on page 20.
- Updated Table 23, "Si3452/3 Port Configuration," on page 23.
- Added "6.2. Changing the Interrupt Mask" on page 24.
- Removed "8.4. Port Current Inaccuracies in dV/dt Mode".
- Updated "12. Ordering Guide" on page 33.

Revision 0.45 to Revision 0.46

- Updated Table 3, "UVLO, and Reset Specifications," on page 5.
- Updated Table 6, "VOUT Drive and Power-on Specifications," on page 7.
 - Changed current limit to 2x for PoE+ mode.
- Updated Table 10, "Address Pin Electrical Specifications*," on page 8.
 - Removed 2.2 V min limit for VIL.
- Updated Table 11, "SMBus (I2C) Timing Specifications (see Figure 1)," on page 9.
 - Changed data hold time to 200 nsec.
- Updated text in "7. PCB Layout Guidelines" on page 25.
- Updated text in "12.1. Evaluation Kits and Reference Designs" on page 33.

Revision 0.46 to Revision 0.47

- Changed SDA and SCL input low to 0.85 V.
- Minor editorial corrections.

CONTACT INFORMATION

Silicon Laboratories Inc.

400 West Cesar Chavez
Austin, TX 78701
Tel: 1+(512) 416-8500
Fax: 1+(512) 416-9669
Toll Free: 1+(877) 444-3032

Please visit the [Silicon Labs Technical Support](#) web page and register to submit a technical support request.

The information in this document is believed to be accurate in all respects at the time of publication but is subject to change without notice. Silicon Laboratories assumes no responsibility for errors and omissions, and disclaims responsibility for any consequences resulting from the use of information included herein. Additionally, Silicon Laboratories assumes no responsibility for the functioning of undescribed features or parameters. Silicon Laboratories reserves the right to make changes without further notice. Silicon Laboratories makes no warranty, representation or guarantee regarding the suitability of its products for any particular purpose, nor does Silicon Laboratories assume any liability arising out of the application or use of any product or circuit, and specifically disclaims any and all liability, including without limitation consequential or incidental damages. Silicon Laboratories products are not designed, intended, or authorized for use in applications intended to support or sustain life, or for any other application in which the failure of the Silicon Laboratories product could create a situation where personal injury or death may occur. Should Buyer purchase or use Silicon Laboratories products for any such unintended or unauthorized application, Buyer shall indemnify and hold Silicon Laboratories harmless against all claims and damages.

Silicon Laboratories and Silicon Labs are trademarks of Silicon Laboratories Inc.

Other products or brandnames mentioned herein are trademarks or registered trademarks of their respective holders.