

PART NO.	ENGINEERING NO.	FINISHED LENGTH
1300660319	3R4106A84M0033	0.3M (11.81 FT)
1300662015	3R4106A84M0203	2M (6 FT 6.74 IN)
1300662017	3R4106A84M0403	4M (13 FT 1.48 IN)

CABLE LENGTH TOLERANCES
 <.3M [1FT]: +19mm-0 [+ .75in-0]
 .3 - .9M [1 - 3FT]: +44.5mm-0 [+1.75in-0]
 .9 - 1.8M [3 - 6FT]: +55.6mm-0 [+2.19in-0]
 1.8 - 3.7M [6 - 12FT]: +88.9mm-0 [+3.50in-0]
 3.7 - 7.3M [12 - 24FT]: +165.1mm-0 [+6.50in-0]
 7.3-14.6M [24 - 48FT]: +317.5mm-0 [+12.50in-0]
 14.6 - 30.5M [48-100FT]: +622.3mm-0 [+24.50in-0]
 OVER 30M [100FT] +2% OF FINISHED LENGTH

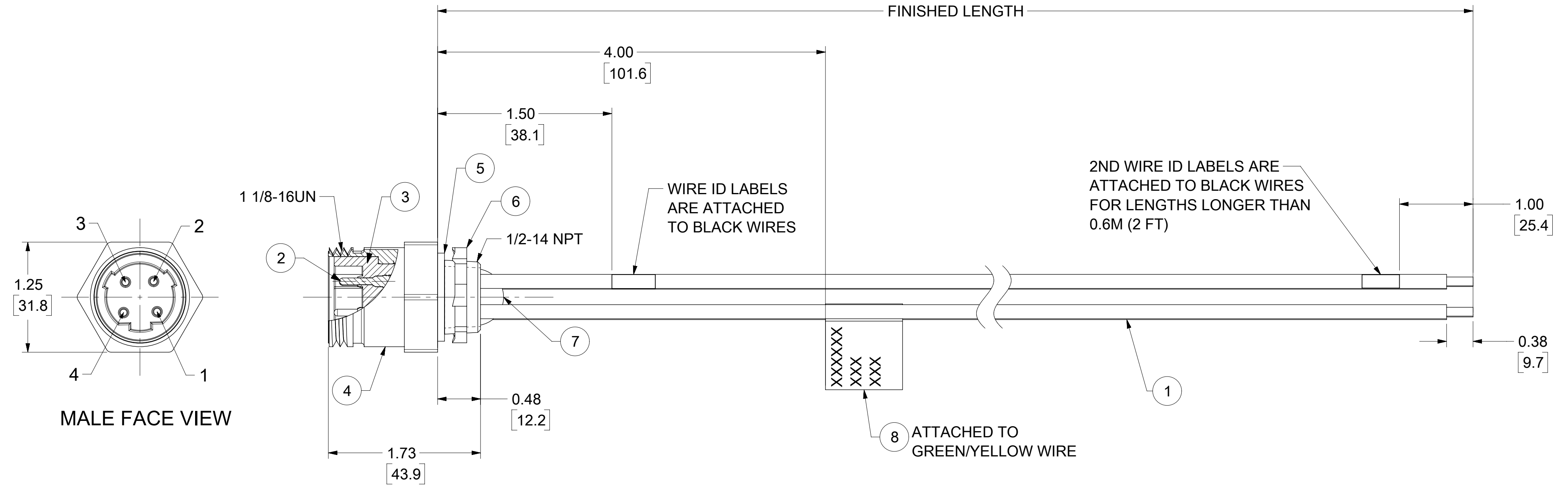
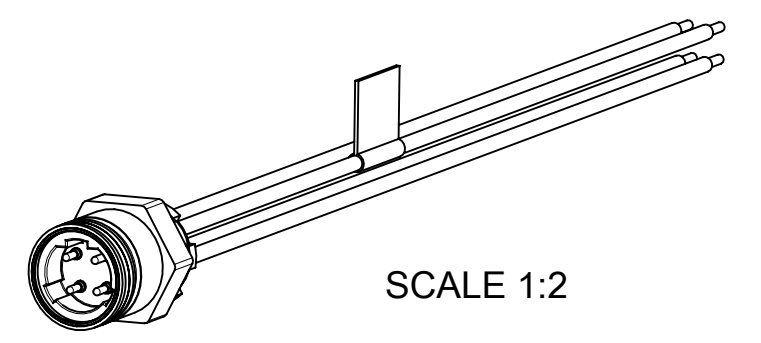

- NOTES:
- MATERIAL: AS NOTED
 - FINISH: AS NOTED
 - ELECTRICAL:
 VOLTAGE: 483V PER IEC60664 (B2)
 600V PER UL2237
 CURRENT: 25A
 - TEMP RATING: -20°C TO +105°C (B2)
 - PROTECTION: IP67 (WHEN MATED)
 - UL LISTED FILE: 258922
 - ALL DIMS ARE FOR REFERENCE UNLESS TOLERANCED OR NOTED OTHERWISE

WIRING DIAGRAM

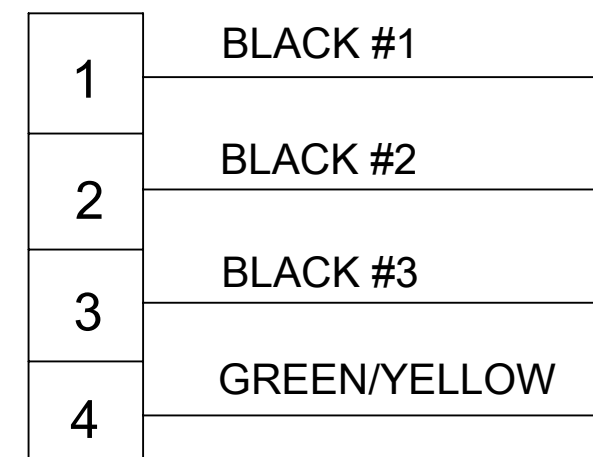

PART NUMBER LEGEND (B2)

3R4106A84M0033

FINISHED LENGTH
 M001 = 0.1 METER
 M010 = 1 METER
 M100 = 10 METER

ITEM	DESCRIPTION	MATERIAL	FINISH
8	FLAG LABEL	VINYL	YELLOW
7	POTTING MATERIAL	EPOXY	BLACK
6	LOCKNUT	STEEL	ZINC PLATED
5	GASKET	NITRILE	BLACK
4	RECEPTACLE SHELL	Cu ALLOY	NICKEL PLATED
3	4P MALE INSERT	TPE	BLACK
2	PIN CONTACT	Cu ALLOY	GOLD OVER NICKEL
1	#12 AWG, WIRE, 1015/TEW	PVC	SEE WIRING DIAGRAM
ITEM	DESCRIPTION	MATERIAL	FINISH

FUNCTIONAL SYMBOLS										THIS DRAWING CONTAINS INFORMATION THAT IS PROPRIETARY TO MOLEX ELECTRONIC TECHNOLOGIES, LLC AND SHOULD NOT BE USED WITHOUT WRITTEN PERMISSION									
DIMENSION UNITS					SCALE					CURRENT REV DESC: UPDATED IEC VOLT, TEMP RATING, GENERAL NOTES, MATERIAL TABLE & TOL. TABLE									
INCH/MM					1.2:1														
GENERAL TOLERANCES (UNLESS SPECIFIED)																			
4 PLACES ±					MM					INCH									
3 PLACES ±																			
2 PLACES ±																			
1 PLACE ±																			
0 PLACES ±																			
ANGULAR TOL ± °																			
DRAFT WHERE APPLICABLE MUST REMAIN WITHIN DIMENSIONS					THIRD ANGLE PROJECTION					DRAWING SERIES									
					C-SIZE					130066									
DOCUMENT STATUS			P1			RELEASE DATE			2022/08/22			20:40:26							
DOCUMENT NUMBER			1300660319			DOC TYPE			PSD			DOC PART			000				
SHEET NUMBER			1 OF 1			REVISION			B2										