

6

5

4

3

2

1

APPROVED: _____

DATE: _____ TITLE: _____

| | | | | |
|-----|-------|-------------|------|------|
| Rev | AWO # | Description | Date | Appr |
|-----|-------|-------------|------|------|

SEE SHT 1 OF 4 FOR REVISION

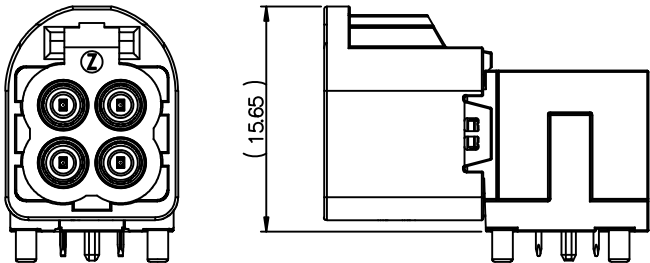
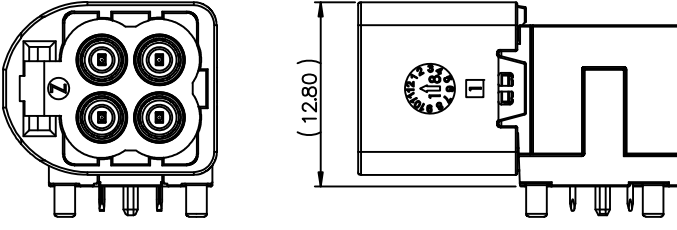
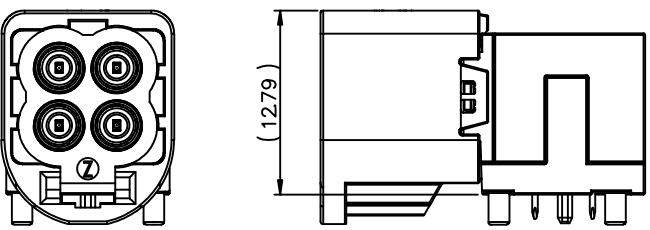
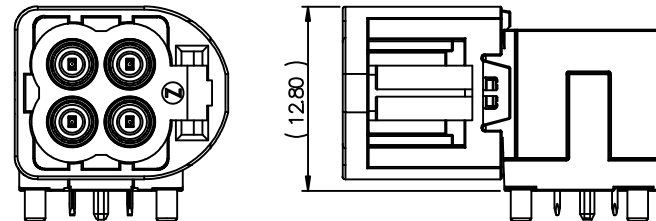
| | | | |
|---|------------|--|--|
| D | PartNumber | MHSD-04X-AM-PRA-T/R | MHSD-04X-AM-PRC-T/R |
| | Direction | STANDARD ORIENTATION  | 90° ORIENTATION  |
| C | PartNumber | MHSD-04X-AM-PRB-T/R | MHSD-04X-AM-PRD-T/R |
| | Direction | 180° ORIENTATION  | 270° ORIENTATION  |

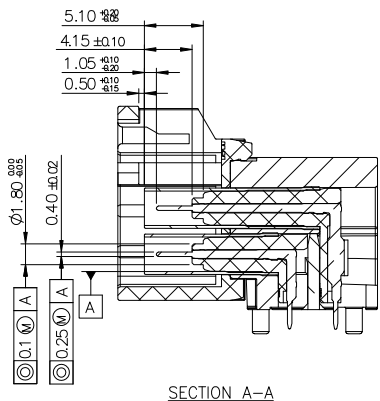

SECTION A-A

UNLESS OTHERWISE SPECIFIED ALL DIMENSIONS ARE MILLIMETERS. TOLERANCES: EXCEPT AS NOTED

| | | |
|-----|--------|-------|
| | MM | ANGLE |
| X. | ± 0.50 | ± 5° |
| .X | ± 0.30 | |
| .XX | ± 0.20 | |

| | | |
|----------|----|---------|
| DRAWN | JJ | 9/13/21 |
| CHECKED | KC | 9/13/21 |
| APPROVED | | |

THIS DRAWING CONTAINS INFORMATION THAT IS PROPRIETARY AND SHOULD NOT BE USED WITHOUT PRIOR WRITTEN PERMISSION FROM ADAM TECH

ADAM TECH

909 Rahway Avenue,
Union, NJ 07083
Phone: 908-687-5000
Fax: 908-687-5710

| | | |
|--------------------------------------|---------------------------------|--------------|
| TITLE MINI FAKRA RIGHT ANGLE PLUG | | |
| SIZE X | PART NO. MHSD-04X-AM-PRX-T/R | REV. D |
| REF: S00013T | SCALE: NTS | SHEET 2 OF 4 |

6

5

4

3

2

1

6

5

4

3

2

1









APPROVED: _____

DATE: _____ TITLE: _____

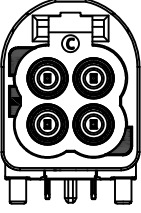
| | | | | |
|-----|-------|-------------|------|------|
| Rev | AWO # | Description | Date | Appr |
|-----|-------|-------------|------|------|

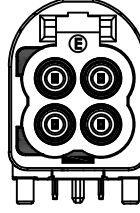
SEE SHT 1 OF 4 FOR REVISION

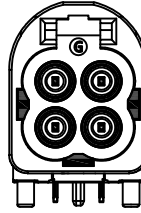
MHSD-04X-AM-PRX-T/R

| | | | | | | | |
|--------|--|---|--|---|---|---|---|
| Coding | A | B | C | D | E | F | G |
| Plug |  |  |  |  |  |  |  |
| Color | BLACK | WHITE | BLUE | CLARET VIOLET | GREEN | BROWN | PLATINUM GREY |
| Coding | Z | | | | | | |
| Plug |  | | | | | | |
| Color | WATER BLUE | | | | | | |

UNLESS OTHERWISE SPECIFIED ALL DIMENSIONS ARE MILLIMETERS. TOLERANCES: EXCEPT AS NOTED

| | | |
|-----|--------|-------|
| | MM | ANGLE |
| X. | ± 0.50 | ± 5° |
| .X | ± 0.30 | |
| .XX | ± 0.20 | |

**ADAM
TECH**

909 Rahway Avenue,
Union, NJ 07083
Phone: 908-687-5000
Fax: 908-687-5710

| | | |
|----------|----|---------|
| DRAWN | JJ | 9/13/21 |
| CHECKED | KC | 9/13/21 |
| APPROVED | | |

| | | |
|-----------------------------|---------------------|--------------|
| TITLE | | |
| MINI FAKRA RIGHT ANGLE PLUG | | |
| SIZE | PART NO. | REV. |
| X | MHSD-04X-AM-PRX-T/R | D |
| REF: S00013T | SCALE: NTS | SHEET 3 OF 4 |

THIS DRAWING CONTAINS INFORMATION THAT IS PROPRIETARY AND SHOULD NOT BE USED WITHOUT PRIOR WRITTEN PERMISSION FROM ADAM TECH

6

5

4

3

2

1

6

5

4

3

2

1

APPROVED: _____

DATE: _____ TITLE: _____

| | | | | |
|-----|-------|-------------|------|------|
| Rev | AWO # | Description | Date | Appr |
|-----|-------|-------------|------|------|

SEE SHT 1 OF 4 FOR REVISION

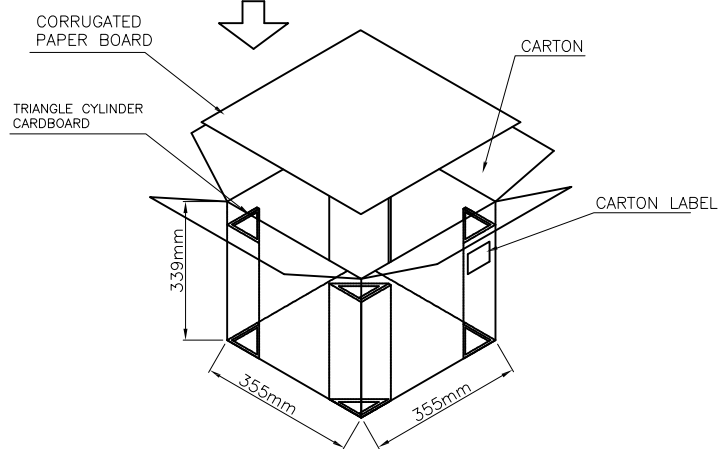
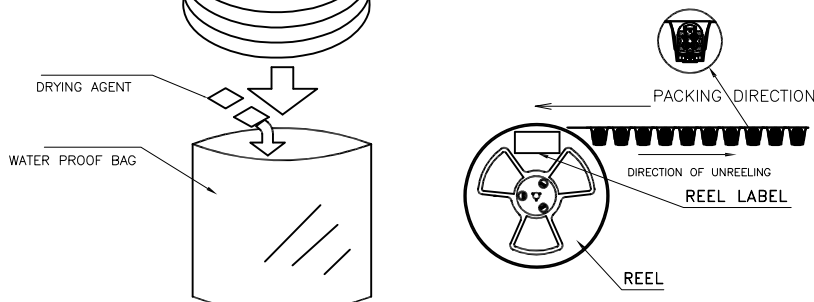
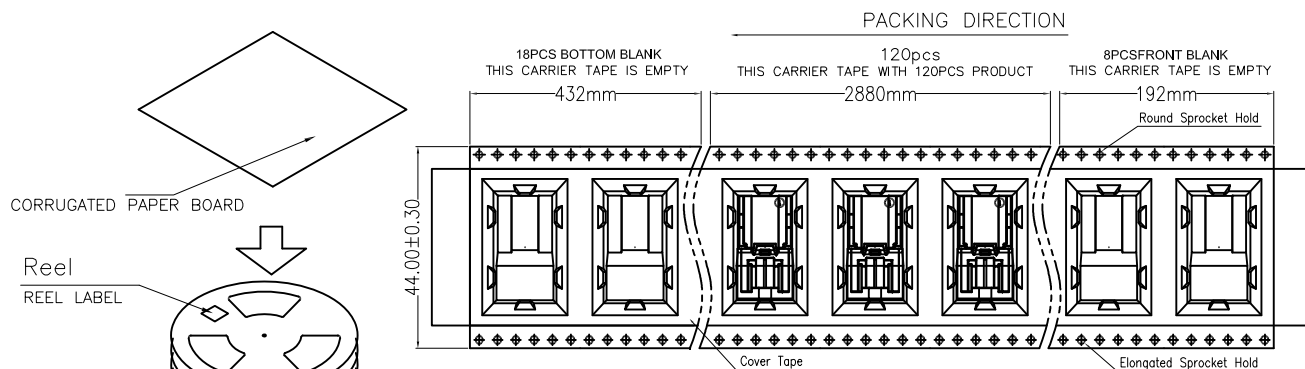

| QUANTITY | | WEIGHT | |
|----------|-------------|---------|---------|
| PCS/REEL | REEL/CARTON | N.W(kg) | G.W(kg) |
| 120 | 6 | 7.38 | 8.38 |

NOTES

1. MATERIALS: PS
2. PACKING: TAPE REEL(120PCS/REEL,720PCS/CARTON)
3. RoHS

All Material in According with the RoHS Environment Related Substances List Controlled.

UNLESS OTHERWISE SPECIFIED ALL DIMENSIONS ARE MILLIMETERS. TOLERANCES: EXCEPT AS NOTED

| | | |
|-----|--------|-------|
| | MM | ANGLE |
| X. | ± 0.50 | ± 5° |
| .X | ± 0.30 | |
| .XX | ± 0.20 | |

ADAM TECH

909 Rahway Avenue,
Union, NJ 07083
Phone: 908-687-5000
Fax: 908-687-5710

| | | |
|----------|----|---------|
| DRAWN | JJ | 9/13/21 |
| CHECKED | KC | 9/13/21 |
| APPROVED | | |

| | | |
|-----------------------------|---------------------|------|
| TITLE | | |
| MINI FAKRA RIGHT ANGLE PLUG | | |
| SIZE | PART NO. | REV. |
| X | MHSD-04X-AM-PRX-T/R | D |

THIS DRAWING CONTAINS INFORMATION THAT IS PROPRIETARY AND SHOULD NOT BE USED WITHOUT PRIOR WRITTEN PERMISSION FROM ADAM TECH

| | | |
|--------------|------------|--------------|
| REF: S00013T | SCALE: NTS | SHEET 4 OF 4 |
|--------------|------------|--------------|

6

5

4

3

2

1