

THIS DRAWING IS UNPUBLISHED. RELEASED FOR PUBLICATION 20
 © COPYRIGHT 20 ALL RIGHTS RESERVED.

LOC		DIST		REVISIONS			
P	LTR	DESCRIPTION	DATE	DWN	APVD		
		D2	REVISED PER ECO-12-007964	02MAY2012	KH	MS	
		D3	REVISED PER ECO-22-177495	30SEPT2022	SM	PS	

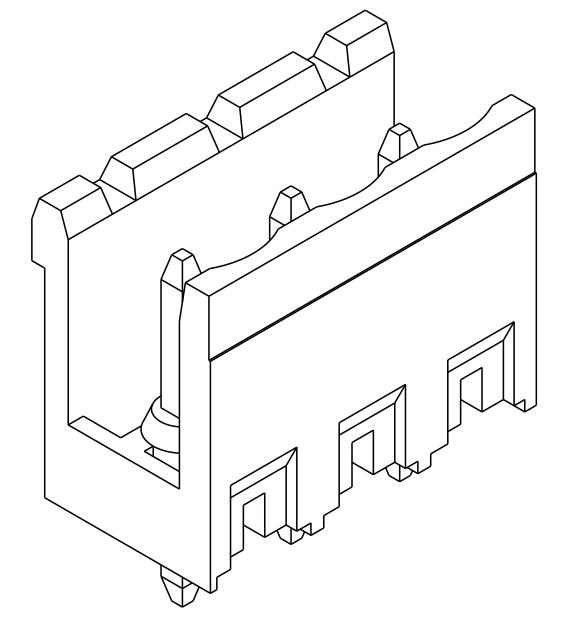
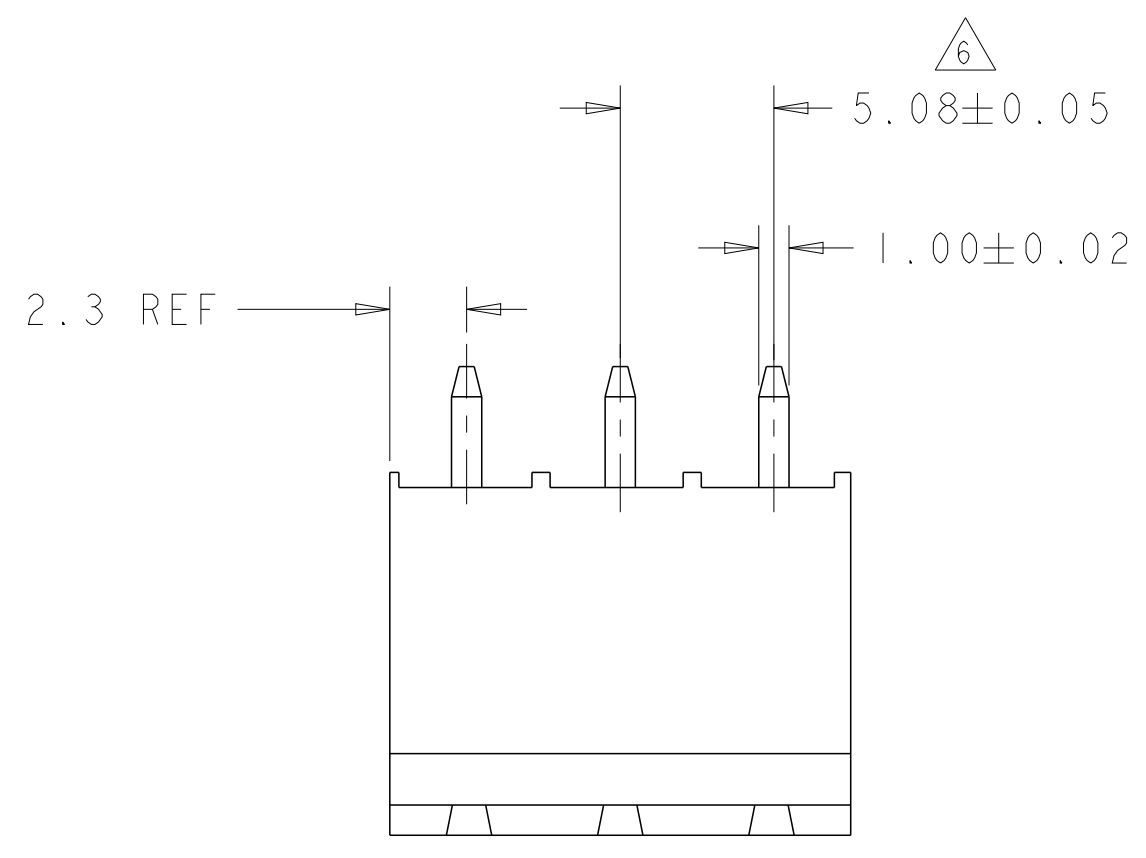

282825-3 AS SHOWN

- 1. MATERIALS AND FINISH
 HOUSING: PA 6-6, UL 94-V0, COLOR GREEN.
 TERMINAL: COPPER ALLOY, FINISH: SEE TABLE.
 - 2. SUITABLE FOR 1,6-2,4mm PC BOARD THICKNESS.
 - 3. END-TO-END STACKABLE WITHOUT LOSS OF CENTERLINE SPACING.
 - 4. RECOGNIZED UNDER THE COMPONENT PROGRAM OF UNDERWRITERS LABORATORIES INC. FILE N°E60677.
 - 5. IMQ CERTIFICATE WITH SURVEILLANCE IN CONFORMITY WITH IEC 998-1/998-2-1.
6. NOT CUMULATIVE TOLERANCE.

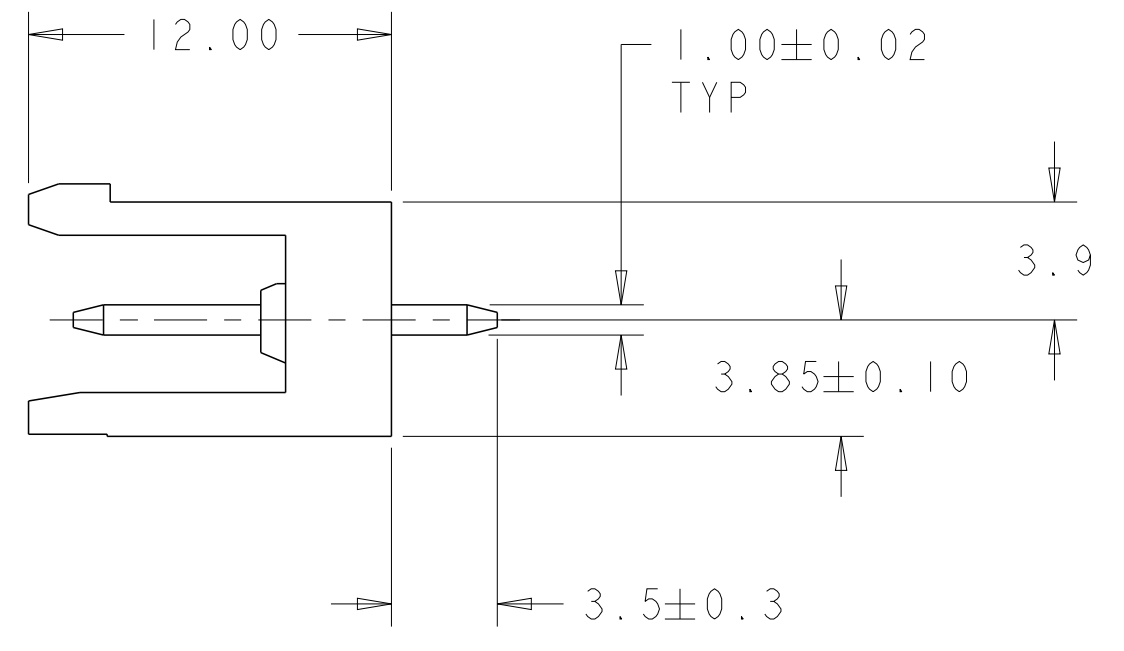
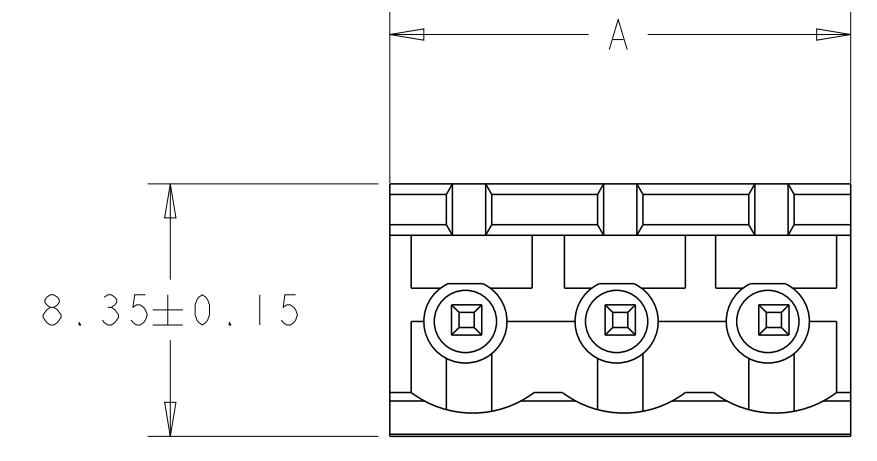

.000008 GOLD OVER NICKEL	9.68	2	2-282825-6
TIN PLATED	126.52	25	2-282825-5
TIN PLATED	121.44	24	2-282825-4
TIN PLATED	116.36	23	2-282825-3
TIN PLATED	111.28	22	2-282825-2
TIN PLATED	106.20	21	2-282825-1
TIN PLATED	101.12	20	2-282825-0
TIN PLATED	96.04	19	1-282825-9
TIN PLATED	90.96	18	1-282825-8
TIN PLATED	85.88	17	1-282825-7
TIN PLATED	80.80	16	1-282825-6
TIN PLATED	75.72	15	1-282825-5
TIN PLATED	70.64	14	1-282825-4
TIN PLATED	65.56	13	1-282825-3
TIN PLATED	60.48	12	1-282825-2
TIN PLATED	55.40	11	1-282825-1
TIN PLATED	50.32	10	1-282825-0
TIN PLATED	45.24	9	282825-9
TIN PLATED	40.16	8	282825-8
TIN PLATED	35.08	7	282825-7
TIN PLATED	30.00	6	282825-6
TIN PLATED	24.92	5	282825-5
TIN PLATED	19.84	4	282825-4
TIN PLATED	14.76	3	282825-3
TIN PLATED	9.68	2	282825-2
TERMINAL FINISH	A	NO OF POSN	PART NUMBER

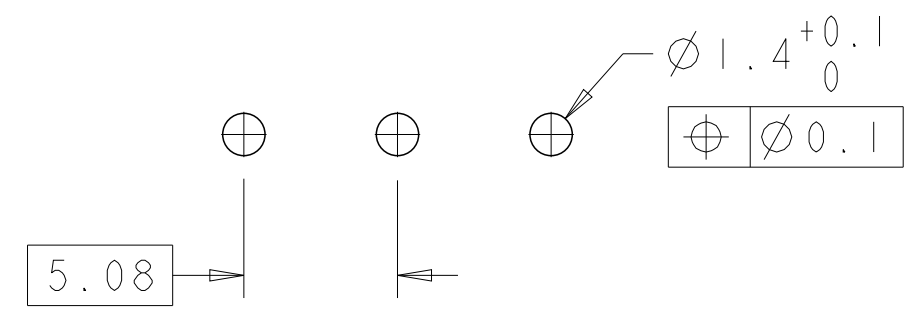

RECOMMENDED PC BOARD LAYOUT

THIS DRAWING IS A CONTROLLED DOCUMENT.

DWN: E. ZANOLINI 30 JUL 2001
 CHK: D. BIEVENOUR 30 JUL 2001
 APVD: D. BIEVENOUR 30 JUL 2001

TE Connectivity

NAME: TERMINAL BLOCK HEADER ASSEMBLY
 180 DEG OPEN ENDS, STACKING
 5.08mm PITCH

PRODUCT SPEC: 108-20166
 APPLICATION SPEC: 114-20079

SIZE: A2 CAGE CODE: 00779 DRAWING NO: C-282825 RESTRICTED TO: 1

MATERIAL: 1 TOLERANCES UNLESS OTHERWISE SPECIFIED: 1

0 PLC ±-
 1 PLC ±.3
 2 PLC ±.25
 3 PLC ±-
 4 PLC ±-
 ANGLES ±2
 FINISH 1

CUSTOMER DRAWING SCALE: 3:1 SHEET 1 OF 1 REV: D3