

1. MECHANICAL DIMENSIONS :

| REV. | DATE | DESCRIPTION |
|------|--------------|-------------|
| 01 | Dec. 14, '17 | 1st RELEASE |
| | | |
| | | |

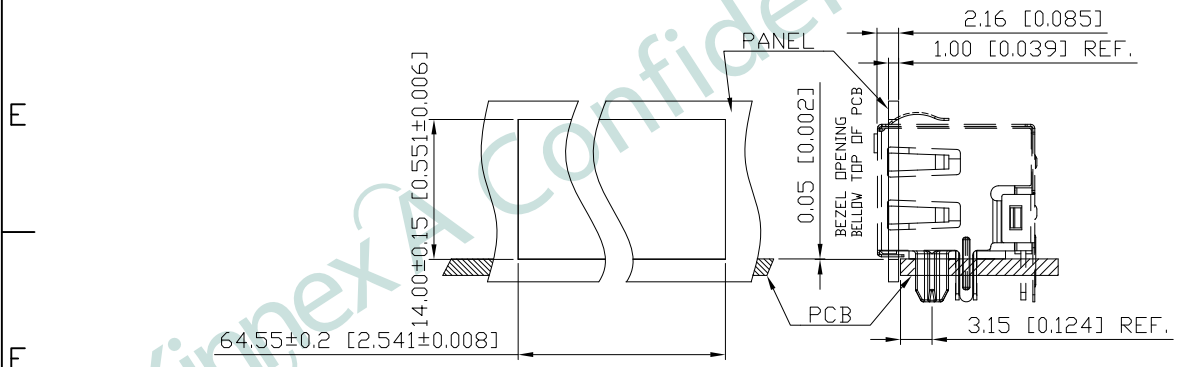
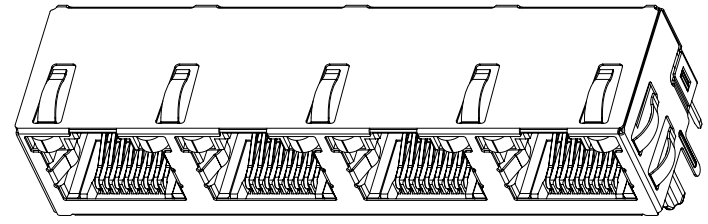
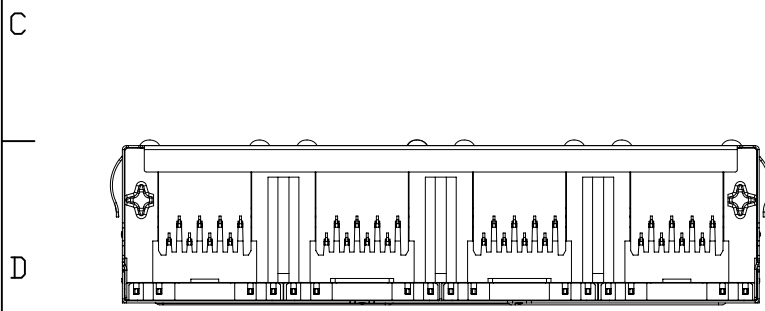
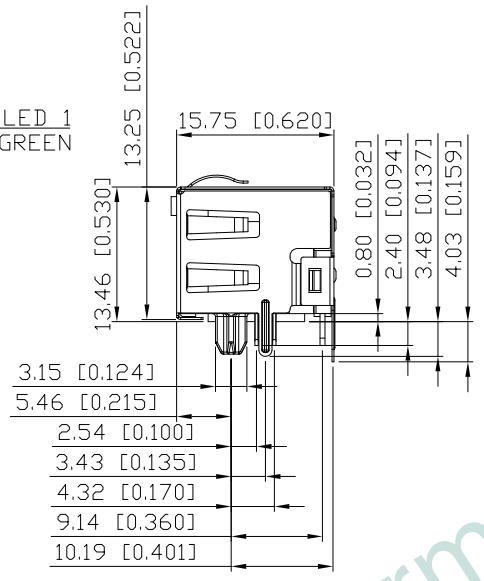
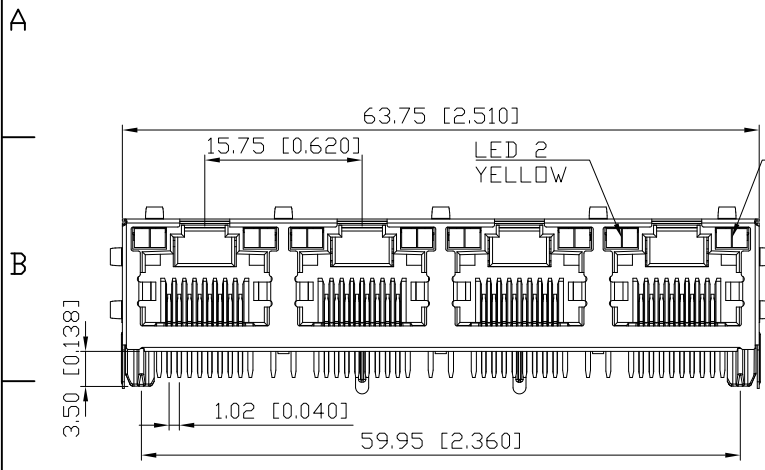

RECOMMENDED
PANEL CUTOUT DIMENSION

- NOTES:
- MATERIAL:
HOUSING: HIGH THERMOPLASTIC, UL94V-0, BLACK
CONTACTS: T=0.35mm PHOS-BRONZE,
GOLD FLASH PLATING ON CONTACT AREA,
TIN PLATING ON SOLDER AREA
SHIELD: T=0.20mm COPPER ALLOY, NICKEL PLATING
 - OPERATING TEMPERATURE: -40°C~+85°C
 - INSERTION FORCE: 4 POUNDS MAX.
EXTRACTION FORCE: 4 POUNDS MAX.
 - DURABILITY: 750 MATING CYCLED MIN.
 - CAVITY CONFORMS TO FCC RULES AND REGULATIONS PART 68,
SUBPART F.
 - UNSPECIFIED TOLERANCE: .XX ±0.25[0.010]
.X ±0.30[0.012]

| PART NO | | KRM-S-04-8-8-1-1G5 | | |
|----------|--------------------------------|--------------------|--------------|--------|
| TITLE | RJ45 1X4 8P8C, W/LED, SHIELDED | | | |
| REV : 01 | | | | |
| UNIT | DRAWN | CHKD | DATE | SHEET |
| mm[inch] | CINDY | DANIEL | Dec. 14, '17 | 1 of 3 |

2. PCB LAYOUT :

A

B

C

D

E

F

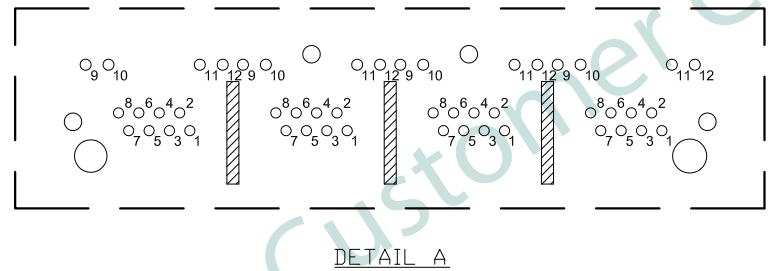
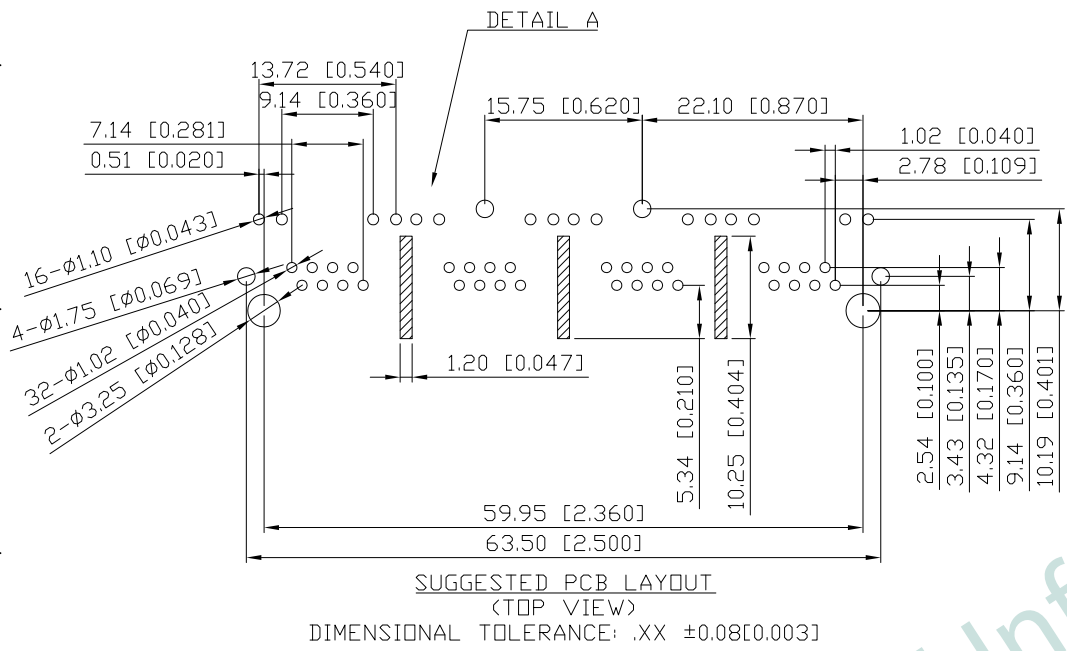

| COLOR | VF(V) @20mA | | IV(mcd) @20mA | IF(mA) | PEAK WAVE LENGTH λP(nm) @20mA |
|--------|----------------|-----|------------------|--------|----------------------------------|
| | TYP | MAX | TYP | TYP | TYP |
| YELLOW | 2.2 | 2.6 | 15 | 20 | 588 |
| GREEN | 2.2 | 2.6 | 10 | 20 | 570 |

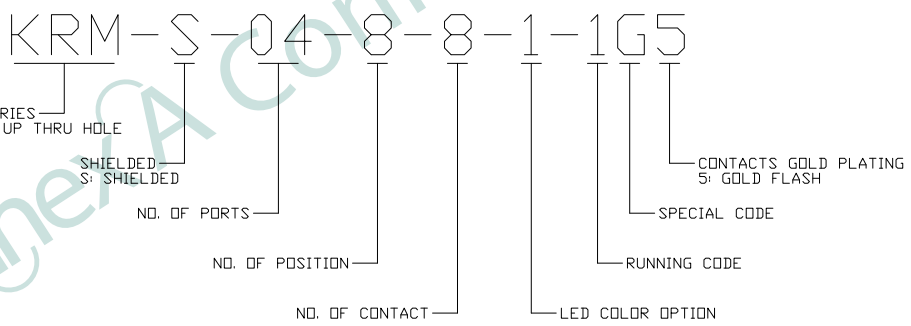

| | | | | |
|----------------------------|--------------------------------|--------|--------------|--------|
| PART NO KRM-S-04-8-8-1-1G5 | | | | |
| TITLE | RJ45 1X4 8P8C, W/LED, SHIELDED | | | |
| REV : 01 | | | | |
| UNIT | DRAWN | CHKD | DATE | SHEET |
| mm[inch] | CINDY | DANIEL | Dec. 14, '17 | 2 of 3 |

3. PROFILE OF WAVE SOLDER :

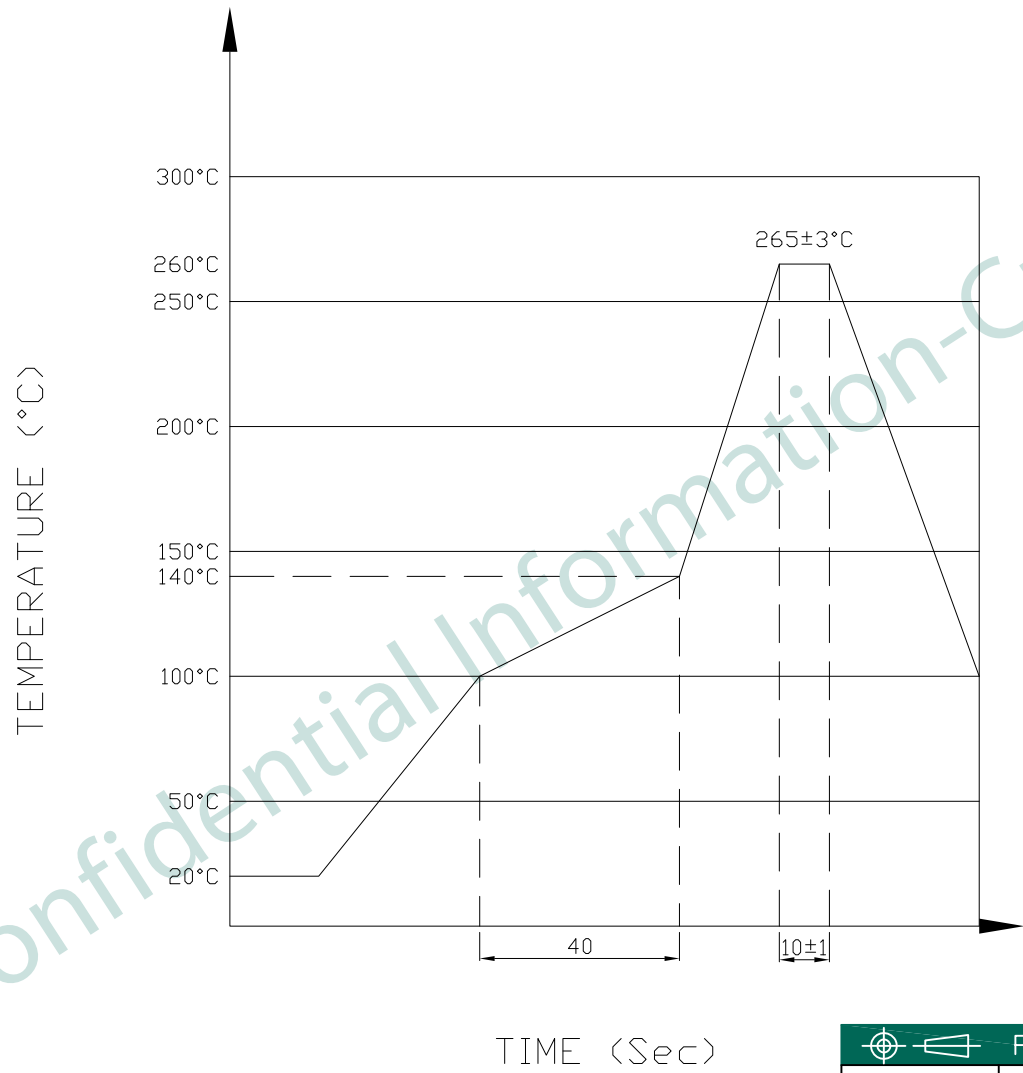

The measuring point for the specified temperature shall be on the soldered part of the lead

| | | | | |
|----------|--------------------------------|--------------------|--------------|--------|
| PART NO | | KRM-S-04-8-8-1-1G5 | | |
| TITLE | RJ45 1X4 8P8C, W/LED, SHIELDED | | | |
| REV : 01 | | | | |
| UNIT | DRAWN | CHKD | DATE | SHEET |
| mm[inch] | CINDY | DANIEL | Dec. 14, '17 | 3 of 3 |