

Fig. 1

## 1. INTRODUCTION

This instruction sheet (IS) covers the installation and inspection procedures of AMP Die Assemblies 313719-1 and 313720-1. The die assemblies are used with AMP Pneumatic Tool 58318-1. The assembled tool is used to crimp a variety of SMA, TNC, and N Series Connectors to RG-402 (.141 dia) and RG-405 (.086 dia) semi-rigid coaxial cable. Refer to IS 9351 for information concerning application and operating procedures for the pneumatic tool. Read these instructions carefully before proceeding.

**NOTE**

*All dimensions on this instruction sheet are in inches.*

## 2. DESCRIPTION (Figure 1)

Each die assembly consists of a machined metal die (left and right staker), and two compression springs (not shown) for each side of the tool. Die Assembly 313719-1 is used with RG-405 cable, and 313720-1 is used with RG-402 cable. For proper type and select-

ion of connector, refer to IS 9351 packaged with the pneumatic tool.

## 3. INSTALLING THE DIE ASSEMBLY

To install the die set in the pneumatic tool, refer to Figure 2 and proceed as follows:

1. Remove top and side die-retaining plates from left side of tool.
2. Insert compression springs into cavities in die "A".
3. Slide spring-loaded die "A" into left side of tool.
4. Replace the top and side die retaining plates on the left side of the tool. Ensure that the springs are seated squarely on the side plate; then tighten the screws.
5. Repeat Steps 1 through 4 to install die "B" in the right side of the tool.

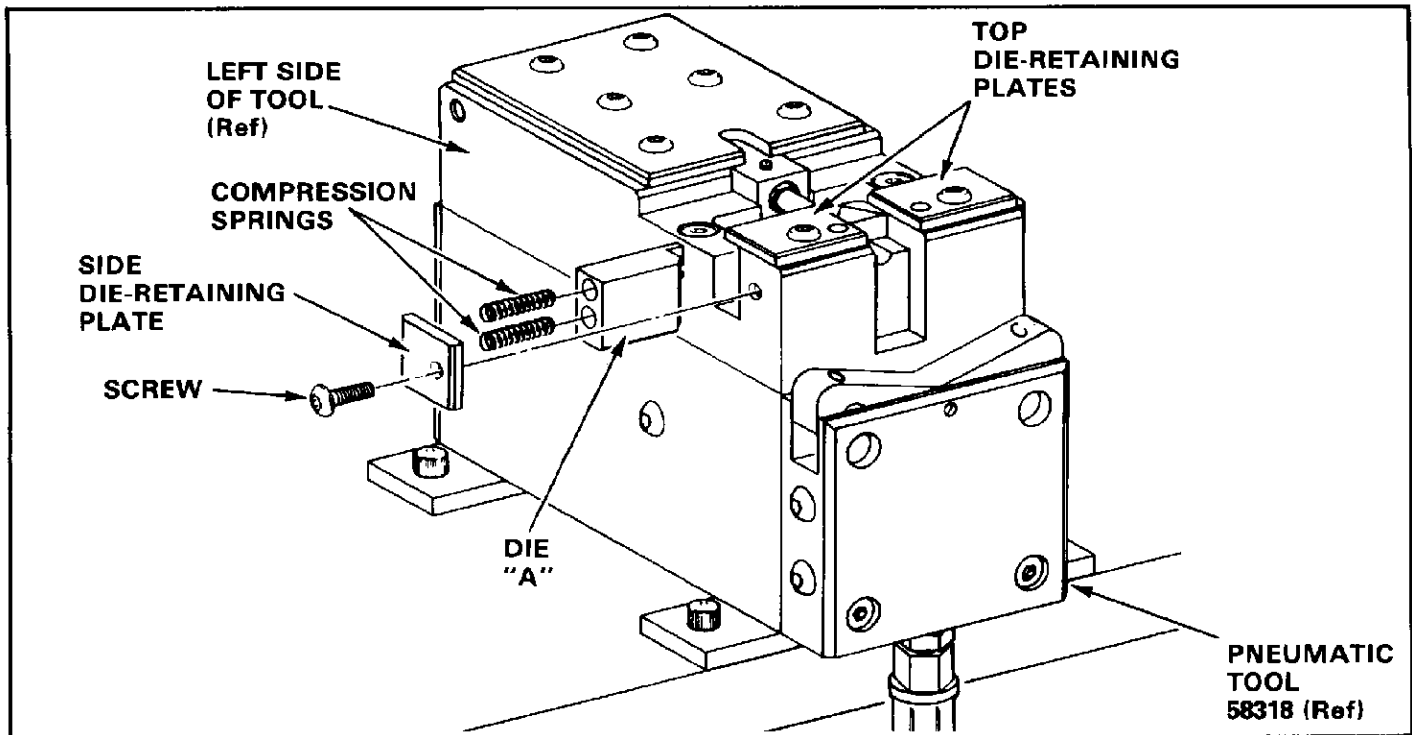
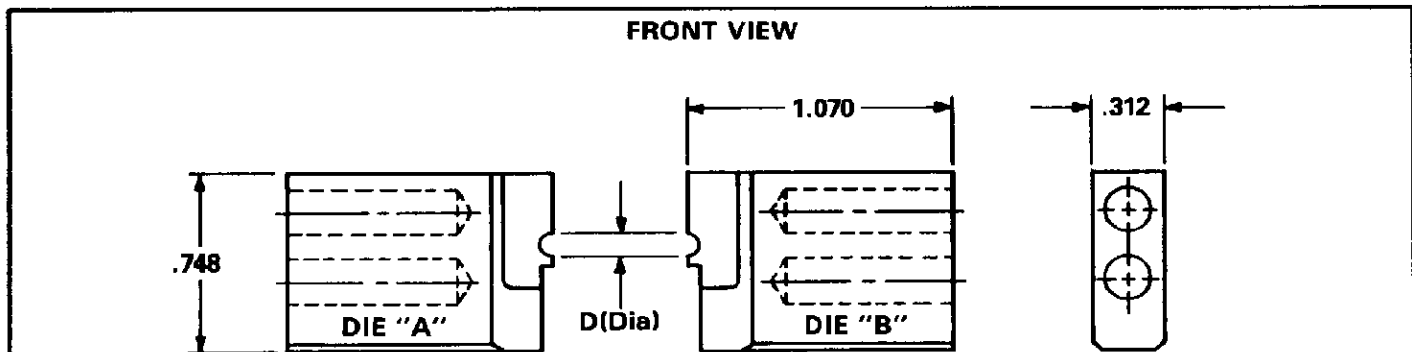

Fig. 2



NOTE: All Dimensions Shown,  $\pm .005$

DIE SET SPECIFICATIONS/REPLACEMENT PARTS				
DIE SET	DIE "A"	DIE "B"	D (DIA)	WT/SET
313719-1	313730-1	313729-1	.090	2.3 OZ
313720-1	313732-1	313731-1	.144	

COMPRESSION SPRINGS, 6-22279-6 (.180 Dia. x 1.00 L); Not Shown; Four Required Per Set

Fig. 3

**4. DIE INSPECTION**

These instructions have been approved by AMP Design, Production, and Quality Control Engineers to provide documented maintenance and inspection procedures in accordance with AMP Corporate Policy No. 3-3. Through AMP test laboratories and the inspection of production assembly, the procedures described herein have been established to ensure quality and reliability of AMP dies.

AMP recommends that the die assembly be inspected immediately upon its arrival at your facility (and at regularly scheduled intervals) to ensure that the dies have not been damaged during handling.

Additional dies can be purchased from:

AMP Incorporated.  
 P. O. Box 3608  
 Harrisburg, PA 17105-3608

or a wholly-owned subsidiary of AMP Incorporated.