



# SPECIFICATION FOR DYNAMIC Speaker

TOTAL PAGE 06 [www.bestargroups.com](http://www.bestargroups.com)

## Characteristics of dynamic Speaker

Customer		Model Name	BTD26-12-08H9 LF
Customer P/N		Product No.	133002
Date	08 Oct. 15	Issue No.	BS/TES01.1550B
Page	01 of 06	Issue Date	2015/08/26

### Approval:

- 1.Characteristics
- 2.Drawing
- 3.Reliability Test
- 4.Packing
- 5.History Change Record

Drawn by	Checked by	Approved by	Customer approved
周颖	王平	张秀琴	

### **BESTAR HOLDING CO.,LTD**

No.199 HuangHe West Road,New district,ChangZhou,JiangSu Province,P.R.China

**Tel:** +86 519 88222567 **Fax:** +86 519 88222551

**E-mail:**[wu@be-star.com](mailto:wu@be-star.com) **<http://www.bestargroups.com>**

# BTD26-12-08H9 LF



## 1.Characteristics

### 1.1 Electrical and Mechanical Characteristics

No.	Item	Specification
1.	Dimension	Ø26.3X9(mm)
2.	AC Impedance	8 Ω ±15%(at 1KHz)
3.	Rated Input Power	2W(4Vrms)
4.	Maximum Input Power	3W(4.9Vrms)
5.	Resonance Frequency	550Hz ±20%
6.	Frequency Response	F0~20KHz
7.	Buzzes & Rattles	Must be normal at sine wave 2.83Vrms
8.	Polarity	Positive voltage to (+),Diaphragm moves forward
9.	Operating Temperature	-40~+ 85°C
10.	Storage Temperature	-40~+ 85°C
11.	Weight	~ 10g

### 1.2 Impedance Curve (only for reference)

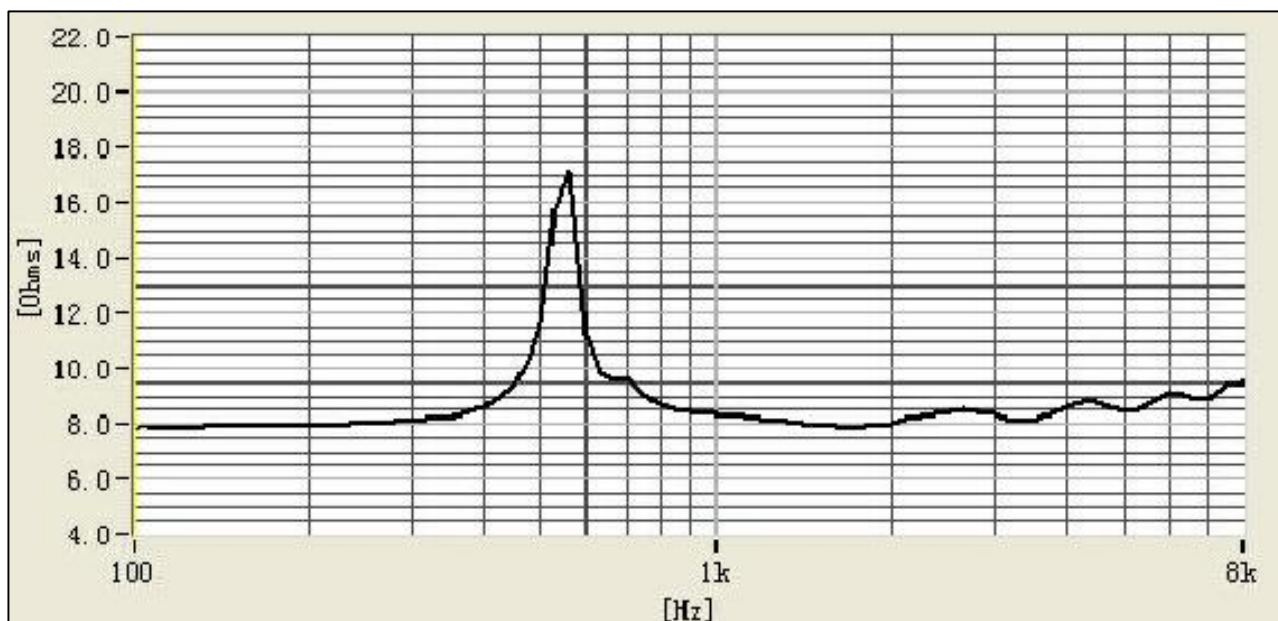

This print and information there in are proprietary to BeStar Holding Co., Ltd and shall not be used in whole or in part without its written content

				Date:	2015/10/08	BTD26-12-08H9 LF
B	2015/10/08	周颖		Drawn by:	周颖	
A	2015/08/26	周颖		Checked by:	王平	Speaker
Rev.	Date	Drawn	Note	Approved by:	张秀琴	
BESTAR HOLDING CO.,LTD				www.bestargroups.com wu@be-star.com		DRG NO: BS/TES01.1550B Page:02 of 06

# BTD26-12-08H9 LF

## 2.Drawing

unit:mm

tolerance:±0.2

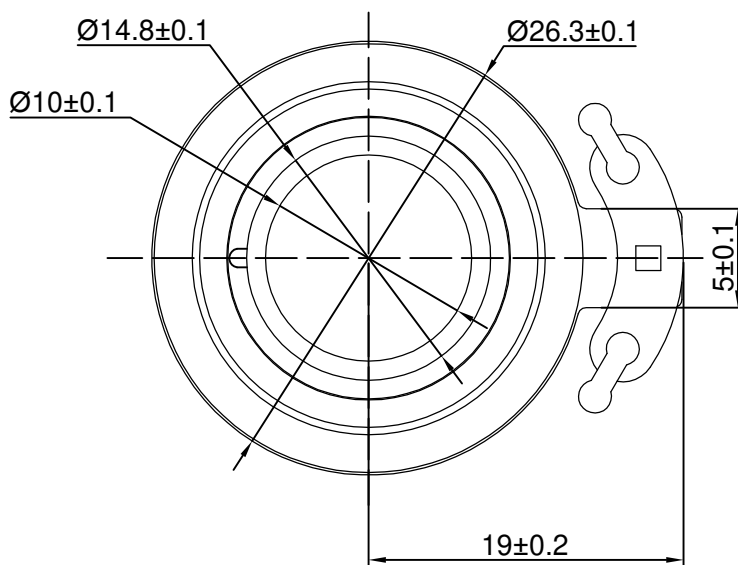
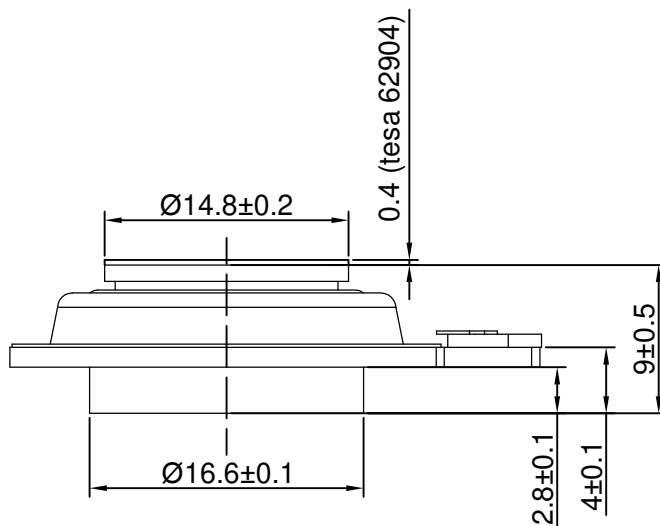

This print and information there in are proprietary to BeStar Holding Co., Ltd. and shall not be used in whole or in part without its written content

				Date:	2015/10/08	BTD26-12-08H9 LF
A	B	2015/10/08	周颖	Drawn by:	周颖	
	A	2015/08/26	周颖	Checked by:	王平	Speaker
Rev.	Date	Drawn	Note	Approved by:	张秀琴	
BESTAR HOLDING CO.,LTD				www.bestargroups.com wu@be-star.com		DRG NO: BS/TES01.1550B
						Page:03 of 06

# BTD26-12-08H9 LF

## 3. Reliability Test

### 3.1 Load Test

Power (Nom)  
Duration

2W(white noise)  
96hrs

### 3.2 High Temperature Test

Temperature  
Duration

+85±2°C  
96hrs

### 3.3 Low Temperature Test

Temperature  
Duration

-40±2°C  
96hrs

### 3.4 Damp Heat

Temperature  
Relative Humidity  
Duration

40±2°C  
90%-95%RH  
96hrs

### 3.5 Drop Test

Height  
Drop face  
Times

75cm  
free falling on concrete floor  
10 times

### 3.6 Vibration Test

Frequency  
Amplitude

30±15Hz  
1.5mm for 3hrs

### Notice:

1.After test leave at room temperature for 1 hours,SPL shall not deviate by ±3dB from pre-test measurement,and meet above spec.item 5,6,7,8,9

This print and information there in are proprietary to BeStar Holding Co., Ltd and shall not be used in whole or in part without its written content

				Date:	2015/10/08	BTD26-12-08H9 LF	
B	2015/10/08	周颖		Drawn by:	周颖		
A	2015/08/26	周颖		Checked by:	王平	Speaker	
Rev.	Date	Drawn	Note	Approved by:	张秀琴		
BESTAR HOLDING CO.,LTD						DRG NO: BS/TES01.1550B	Page:04 of 06
www.bestargroups.com wu@be-star.com							

# BTD26-12-08H9 LF

## 4. Packing

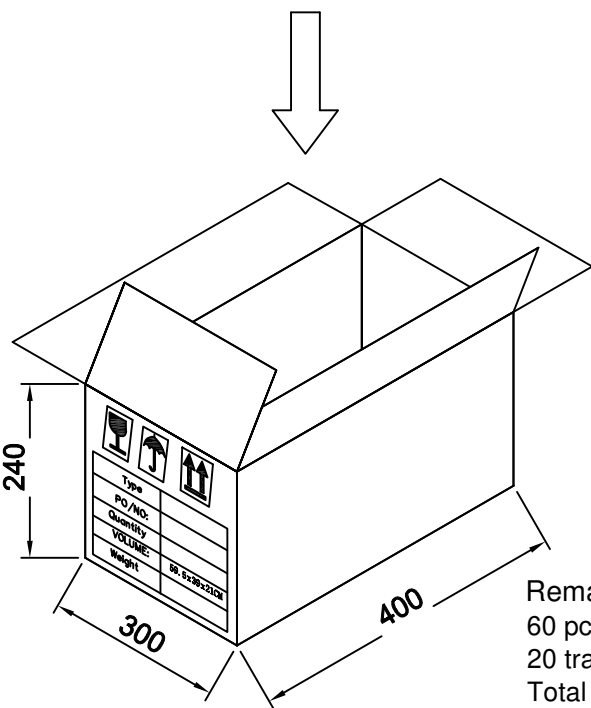
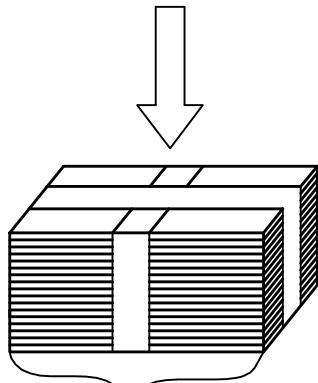
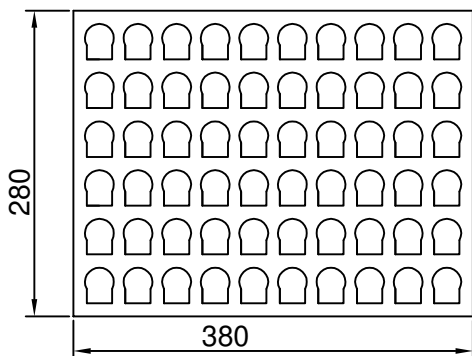

Remark:  
 60 pcs per tray  
 20 trays for unit  
 Total 1200pcs per carton  
 Size: 40×30×24(cm)

This print and information there in are proprietary to BeStar Holding Co., Ltd. and shall not be used in whole or in part without its written content

				Date:	2015/10/08	BTD26-12-08H9 LF
A	B	2015/10/08	周颖	Drawn by:	周颖	
	A	2015/08/26	周颖	Checked by:	王平	Speaker
Rev.	Date	Drawn	Note	Approved by:	张秀琴	
BESTAR HOLDING CO.,LTD				www.bestargroups.com wu@be-star.com		DRG NO: BS/TES01.1550B
						Page:05 of 06

# BTD26-12-08H9 LF

## 5. History Change Record

version No.	Change Items		Date	Drawn	Approved
	Before	After			
A			2015/08/26	周颖	张秀琴
B	0.3(3M9448)	0.4(tesa 62904)	2015/10/08	周颖	张秀琴

This print and information there in are proprietary to BeStar Holding Co., Ltd. and shall not be used in whole or in part without its written content

A	Rev.	Date	Drawn	Note	Date:	2015/10/08	BTD26-12-08H9 LF	
	B	2015/10/08	周颖		Drawn by:	周颖		
	A	2015/08/26	周颖		Checked by:	王平		
					Approved by:	张秀琴	Speaker	
BESTAR HOLDING CO.,LTD						<a href="http://www.bestargroups.com">www.bestargroups.com</a> <a href="mailto:wu@be-star.com">wu@be-star.com</a>	DRG NO: BS/TES01.1550B	Page:06 of 06