

## SUB-CUB 1 & 2 - COMPLETE 6-DIGIT COMPONENT COUNTERS

### APPLICATIONS INCLUDE:

- VENDING MACHINES
- VIDEO GAMES
- COMPUTERS
- UTILITY METERS
- OFFICE COPIERS
- P.C.'S
- FLOW METERS
- TEST EQUIPMENT
- DISPENSING EQUIP.
- MACHINE CONTROLS
- MEDICAL EQUIPMENT
- PORTABLE INSTRUMENTS



### - LSI COUNTER CHIP WITH LCD DISPLAY - SNAP MOUNTS DIRECTLY ON P.C. BOARD

- AVAILABLE IN TWO SIZES  
 SUB-CUB 1 - 0.2" (5 mm) HIGH DISPLAY  
 \*SUB-CUB 2 - 0.35" (8.9 mm) HIGH DISPLAY
- SOLDERLESS, ELASTOMERIC INTERCONNECTS
- ULTRA-LOW POWER, 5 V AT 15  $\mu$ A TYPICAL
- LATCHABLE DISPLAY WITH LEADING ZERO BLANKING
- COUNT RATES TO 500 KHz
- IDEAL IN APPLICATIONS FOR:  
 REGISTER, STATUS & USAGE COUNTING  
 FREQUENCY, EPUT, & RPM INDICATION  
 TIMER, PULSE-WIDTH & PERIOD READOUT
- \* ACCESSORY HARDWARE AVAILABLE FOR PANEL MOUNTING SUB-CUB 2

### DESCRIPTION

As a completely self-contained counter/display module, SUB-CUBs can be treated as a component just like any other I.C. The modules contain a custom monolithic counter/driver chip that performs all the counting functions together with a 6-digit LCD readout. The latchable display with the separate reset function permits these modules to be used as frequency or rate meters, timers, phase-angle or pulse width indicators and for other complex readout requirements in addition to simple high speed counting.

These modules are ideal for internal "on-board" applications where a readout of count, frequency, time, etc. is needed within a circuit enclosure for

maintenance, diagnostic, tune-up, or other data readout requirements. The SUB-CUB 2, with its larger display, can also be mounted with a convenient bezel kit to provide a very flexible and economical panel instrument.

SUB-CUBs snap-mount directly on any 1/16" P.C. Board that has been etched to provide a mating interconnect pad pattern with two mounting holes and a polarizing "key" hole. Interconnections to the P.C. Board as well as internal connections are made with elastomeric connectors that provide corrosion-proof, gas tight, interface contacts for high reliability.

### MOUNTING & DIMENSIONS

Snap in mounting on the P.C. Board is facilitated by two, split, lock-ramp pins which engage mounting holes drilled in the P.C. Board. The silicone rubber elastomeric connectors compress to accommodate P.C. Board thickness variation of  $\pm 0.005"$  (0.13 mm).

### DIMENSIONS In Inches (mm)

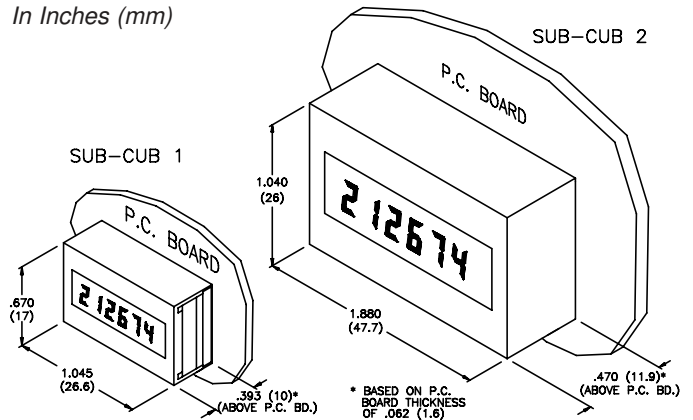
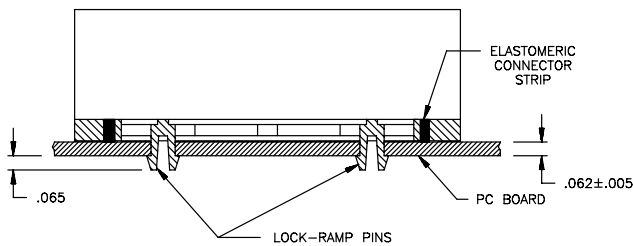

### P.C. BOARD LAYOUT

P.C. Board pads may be gold or tin-lead plated. Pad surface must be flat without excessive tin-lead build-up. (Layout views are from SUB-CUB-D mounting side of board.)

Note: All hole size tolerances  $\pm 0.003"$  (0.08 mm)  
 All other tolerances  $\pm 0.005"$  (0.13 mm)

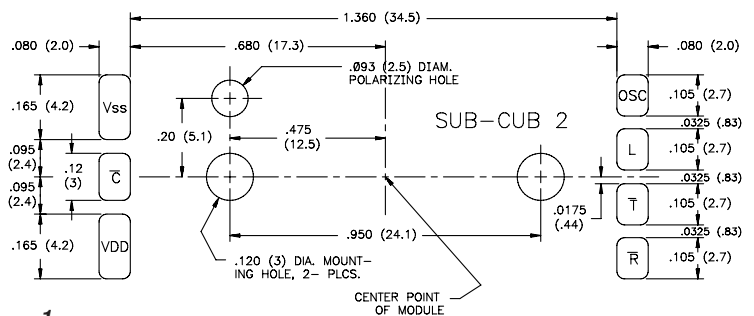
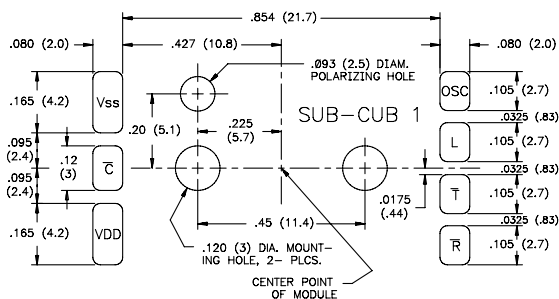

## DEVICE CONNECTIONS \*

**COUNT ( $\overline{C}$ )** - CMOS, Schmidt Trigger; counter increments on negative going transition.

**RESET ( $\overline{R}$ )** - CMOS Schmidt Trigger; counter is reset to zero when input is low. Counter should always be reset to zero whenever power is first applied to the unit.

**LATCH ( $L$ )** - CMOS level-sensitive, asynchronous input. When pulled low, the latches are transparent and display is updated as new counts are received. When latch input is pulled high, the display registers count existing immediately prior to activating the latch.

**TEST ( $\overline{T}$ )** - CMOS level-sensitive input. When this input is high, counter operates normally. When pulled low, carry input to each decade is disconnected and tied to count input so all decades count in parallel to provide rapid testing. This input should be tied high if not used, or driven from an active output that will hold it high. For normal test routine, pull test and reset low, apply one count pulse and then allow reset to return high. Then apply count pulses so all digits increment together from zero.

**OSC.** - This input provides for connection of an external 2.4 Meg. resistor required by the on-board scan oscillator. Oscillator runs at 240 Hz  $\pm 35\%$  and has internal divider to provide 60 Hz back plane drive.

**V<sub>DD</sub>** - +3 or +5 VDC. Supply.

**V<sub>SS</sub>** - Common for D.C. Supply and Inputs.

\* All unused inputs must be tied to either V<sub>DD</sub> or V<sub>SS</sub>, whichever is appropriate.

## BLOCK DIAGRAM

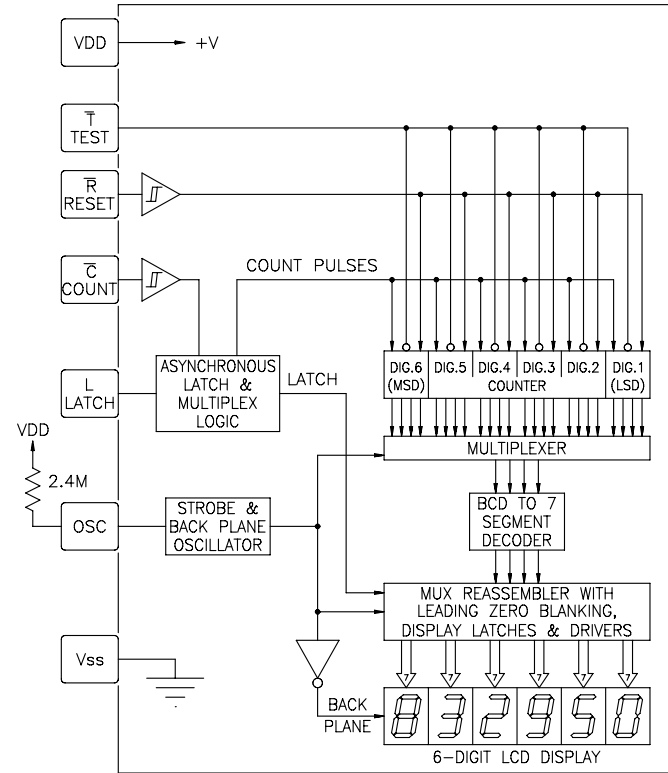

## CAUTION

This device contains CMOS circuitry which requires special anti-static handling to the same degree required by standard CMOS integrated circuits. Units should be stored in the conductive packaging used to ship the devices. Containers should be opened and units handled only on a conductive table top by personnel wearing wrist-strap grounding equipment. These devices have the same protection circuits as standard CMOS devices to prevent damage to inputs due to nominal over-voltage.

## MAXIMUM RATINGS (VOLTAGE REF. TO V<sub>SS</sub>)

RATING	SYMBOL	VALUE	UNIT
DC Supply Voltage	V <sub>DD</sub>	-0.5 to +6.5	VDC
Input Voltage, All Inputs	V <sub>I</sub>	-0.5 to (V <sub>DD</sub> +0.5)	VDC
Operating Temperature	T <sub>A</sub>	-35 to +85	°C
Storage Temperature	T <sub>STG</sub>	-35 to +85	°C

## ELECTRICAL CHARACTERISTICS V<sub>DD</sub> = 5 V $\pm 10\%$ UNLESS OTHERWISE SPECIFIED

SYMBOL	PARAMETER	MIN.	TYP.	MAX.	UNIT	TEST CONDITION
V <sub>DD</sub>	Supply Voltage	2.5		6.0	VDC	
I <sub>DD</sub>	Supply Current		15	22	$\mu$ A	10 KHz Count Rate
I <sub>DDQ</sub>	Quiescent Current		6	12	$\mu$ A	Not Counting
V <sub>IH</sub>	Input High Voltage	3.9	3.0		VDC	
V <sub>IL</sub>	Input Low Voltage		0.9	0.5		
I <sub>IL</sub>	Input Leakage Current		0.01	0.1	$\mu$ A	V <sub>DD</sub> $\geq$ V <sub>IN</sub> $\geq$ V <sub>SS</sub>
f <sub>c max</sub>	Count Frequency	500			KHz	V <sub>DD</sub> = +5 VDC
	(50% Duty Cycle)	250			KHz	V <sub>DD</sub> = +3 VDC
f <sub>osc</sub>	Oscillator Frequency		240		Hz	R EXT = 2.4 M $\pm 10\%$
T <sub>RST</sub>	Reset Pulse Width	10			$\mu$ S	

## TYPICAL APPLICATIONS

### COUNT & CONTROL FROM REMOTE INPUTS

Inputs to SUB-CUBs are CMOS inputs and must be adequately buffered if remote "off-board" signal sources are used. This illustration shows a SUB-CUB being used in an elementary counting application to depict some of the buffering methods that can be used.

The Count Input is buffered by the NPN Transistor input circuit. The base resistance is split into two 10 K resistors, with a filter cap to eliminate spurious counts due to electrical interference pickup. The filter network will allow count rates to 10 KHz with Symmetrical +5 V input count pulses. The 4.7 K across the input would not be required if the circuit supplying the count pulses has a low off-state output impedance.

The Remote Button-actuated Reset input is buffered by a simple RC circuit consisting of two 47 K resistors and a 0.01 mfd capacitor. The Test input is pulled low by the NPN Transistor in the test mode. The Test input can also be driven by an active output from a logic gate. If not used it should be tied to V<sub>DD</sub> to avoid any possibility of spurious interference.

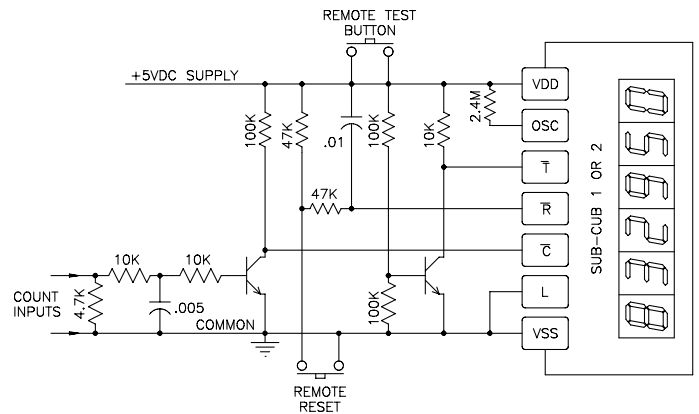

### FREQUENCY, SPEED, FLOW, SPEED-RATIO, PERIOD & CYCLE TIME INDICATIONS

This circuit uses a dual monostable I.C. to generate the proper latch and reset coordination required for frequency or time-period readouts.

When frequency readout is desired, the pulse train whose frequency is to be displayed, is applied to the CLK-A input, (*the inverter, in the CLK-A input, causes the SUB-CUB to increment on the positive going edge of CLK-A pulses and can be omitted if negative edge incrementing is satisfactory*). The CLK-B input is supplied with standard time-base pulses whose period determines the measuring time. For frequency measurement, this time is 1 second so CLK-B input would be supplied with 1 pulse/sec. from a crystal clock or line-reference divider. At the positive going edge of each CLK-B pulse, the first monostable opens the SUB-CUB latch momentarily to update the display to the count existing at that instant of time. Immediately after the latch closes, freezing the updated count on the display, the internal counter in the SUB-CUB display is reset to zero in preparation for a new counting cycle. Thus, at the end of each measuring time interval the SUB-CUB display is updated to readout the number of pulses received during the period, while it is accumulating new counts for the next update.

Frequency ratio can be displayed by replacing the standard time-base (CLK-B) input with a pulse train related to the second variable (*or denominator*) of the ratio. Normally this pulse train is divided by 10, 100, or 1000 before being applied to the CLK-B input to provide a higher resolution reading.

For period or cycle-time indication, CLK-A and B inputs are simply interchanged. CLK-A input is now supplied with standard Clock Pulses, say 1000 Hz to readout in milliseconds, while the pulse train whose period is being measured is applied to the CLK-B input.

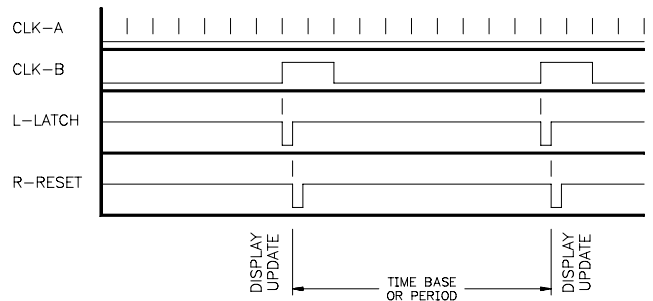
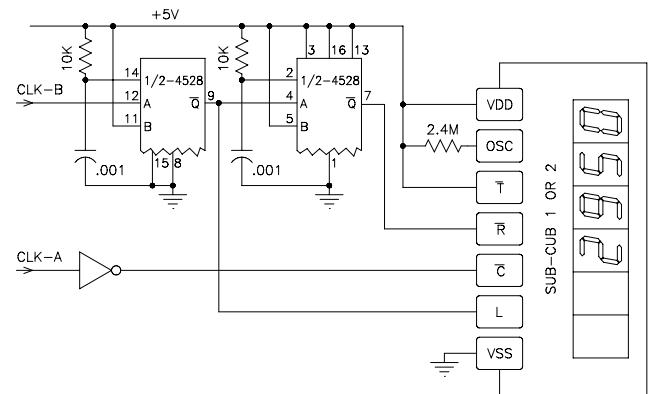

### PULSE WIDTH OR DWELL-TIME READOUT

This circuit also uses two monostables, however for pulse-width readout they function at two different times.

A train of standard clock pulses, whose period determines the readout increments, is applied to the CLK-A input. For example if readout in milliseconds is desired, CLK-A would receive 1 pulse/millisecond, or 1000 Hz. The pulse whose width is to be measured is applied to CLK-B input. At the positive going edge of the CLK-B pulse, the first monostable momentarily resets the SUB-CUB internal counter to zero, and it then begins accumulating counts from the CLK-A time reference pulses. At the conclusion of the CLK-B pulse, the negative going edge momentarily opens the SUB-CUB display latch, and the number of time-reference pulses that have been counted, since reset, is latched on the display to provide a direct readout of CLK-B pulse-width.

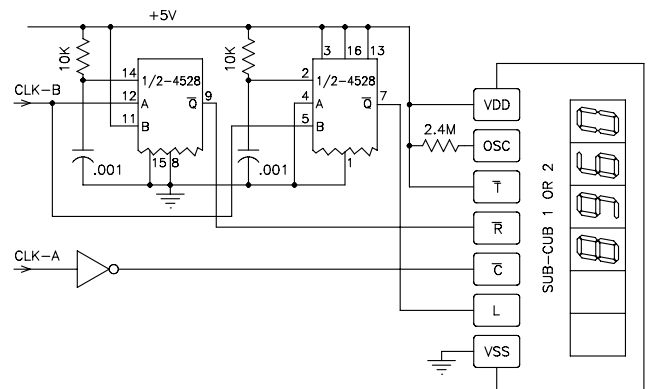

## PANEL BEZEL KIT FOR THE SUB-CUB 2 (P/N HWK40000)

This kit provides a convenient way to adapt the SUB-CUB 2 to panel mounting. The kit includes the black plastic bezel, the panel and internal window gaskets, P.C. Board, 12" ribbon cable and mounting screws.

### ASSEMBLY

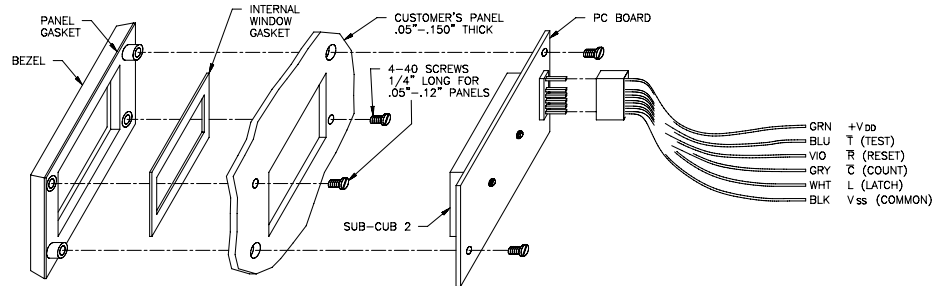

### DIMENSIONS & PANEL CUT-OUT In inches (mm)

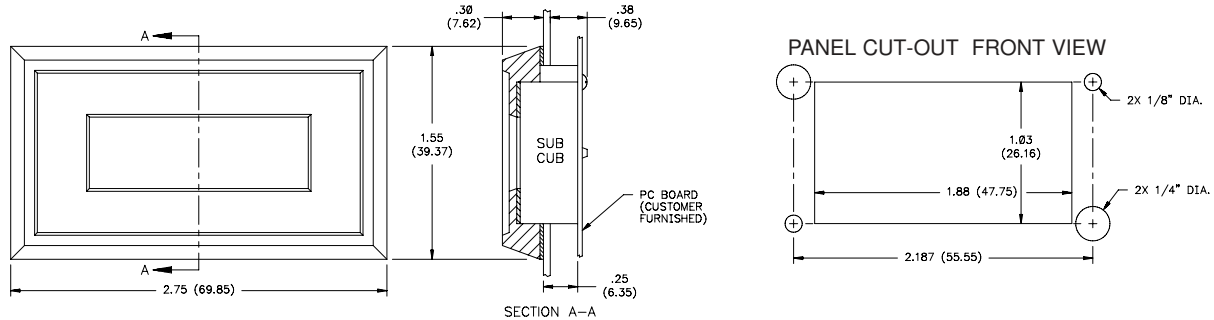

### COMPLETE FUNCTION EVALUATION KIT

This convenient kit allows either the SUB-CUB 1 or SUB-CUB 2 to be run in all operating modes for experimental and evaluation purposes. The kit includes an "on-board" 4.5 V battery and a variable frequency oscillator to supply a train of count pulses. LATCH, RESET, and TEST functions are

pushbutton operated. The SUB-CUB mounting board unplugs and can be used for bread board work (*SUB-CUB Mounting Board is also available separately*). The kit is supplied complete with batteries, but less SUB-CUB Display Counter Module (*See ordering information below*).

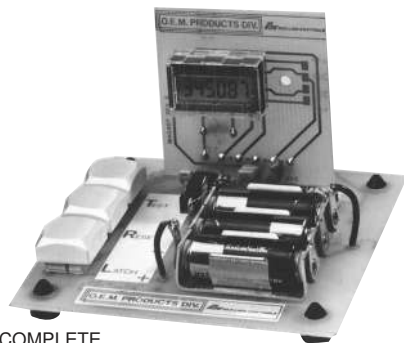

COMPLETE EVALUATION KIT  
P/N DMOSCB01

SEPARATE SUB-CUB  
MOUNTING BOARD  
P/N DMOSCB02

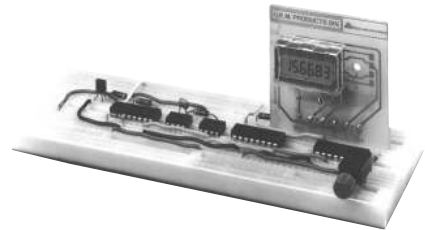
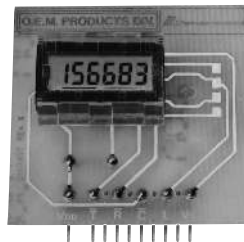

### ORDERING INFORMATION

MODEL NO.	DESCRIPTION	PART NUMBER
SCUB1	SUB-CUB 1 Display/Counter Module	SCUB1000
SCUB2	SUB-CUB 2 Display/Counter Module	SCUB2000
HWK 4	*SUB-CUB 2 Panel Bezel Kit with P.C. Board & Cable	HWK40000
HWK 3	*SUB-CUB 2 Panel Bezel Kit w/o P.C. Board & Cable	HWK30000
	Complete Evaluation Kit With Batteries	DMOSCB01
	SUB-CUB Mounting P.C. Board	DMOSCB02
* SUB-CUB Evaluation Kits Do Not Include SUB-CUB Display/Counter Module. Order SUB-CUB 1 or 2 Module Separately.		