

## CDBW140R-HF Thru. CDBW1100R-HF

Reverse Voltage: 40 to 100 Volts

Forward Current: 1.0 Amp

RoHS Device

Halogen Free

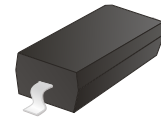

### Features

- Low profile surface mount applications in order to optimize board space.
- Low power loss, high efficiency.
- High current capability, low forward voltage drop.
- High surge capability.
- Guard ring for overvoltage protection.
- Ultra high-speed switching.
- Silicon epitaxial planar chip, metal silicon junction.

### Mechanical data

- Epoxy: UL94-V0 rate flame retardant.
- Case: Molded plastic, SOD-123
- Terminals: Solderable per MIL-STD-750, method 2026.
- Polarity: Indicated by cathode band.
- Weight: 0.010 grams(approx.).

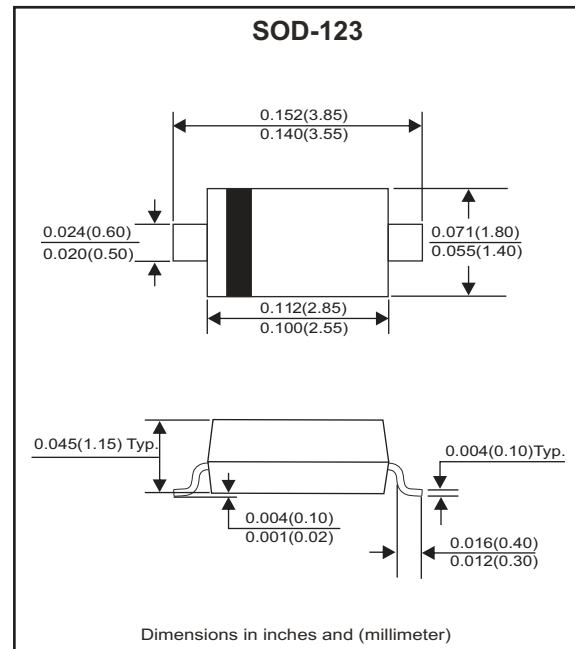

### Maximum Ratings and Electrical Characteristics

Ratings at  $T_a=25^\circ\text{C}$  unless otherwise noted.  
Single phase, half wave, 60Hz, resistive or inductive loaded.  
For capacitive load, derate current by 20% .

Parameter	Symbol	CDBW 140R-HF	CDBW 160R-HF	CDBW 1100R-HF	Units
Max. Repetitive Peak Reverse Voltage	$V_{RRM}$	40	60	100	V
Max. DC Blocking Voltage	$V_{DC}$	40	60	100	V
Max. RMS voltage	$V_{RMS}$	28	42	70	V
Max. Instantaneous Forward Voltage @ 1.0A, $T_A=25^\circ\text{C}$	$V_F$	0.55	0.75	0.86	V
Junction Temperature Range	$T_J$	-50 to +125	-50 to +150		$^\circ\text{C}$
Storage Temperature Range	$T_{STG}$	-50 to +125	-50 to +150		$^\circ\text{C}$

Parameter	Conditions	Symbol	MIN.	TYP.	MAX.	Units
Forward Rectified Current	See Fig.1	$I_o$			1.0	A
Forward Surge Current	8.3ms single half sine-wave superimposed on rate load (JEDEC method)	$I_{FSM}$			5.5	A
Reverse Current	$V_R = V_{RRM}$ $T_A=25^\circ\text{C}$	$I_R$			0.1	mA
Thermal Resistance	Junction to ambient	$R_{\theta JA}$		88		$^\circ\text{C/W}$
Diode Junction Capacitance	f=1MHz and applied 4V DC reverse Voltage	$C_J$		120		pF

Company reserves the right to improve product design , functions and reliability without notice.

REV: B

## RATING AND CHARACTERISTIC CURVES (CDBW140R-HF thru. CDBW1100R-HF)

Fig.1 - Typical Forward Current Derating Curve

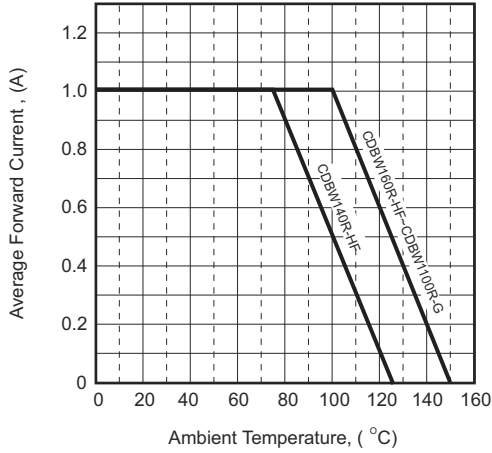

Fig.2 - Typical Forward Characteristics

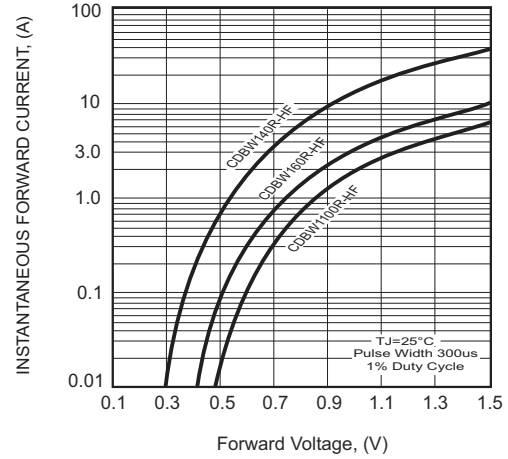

Fig.3 - Typical Junction Capacitance

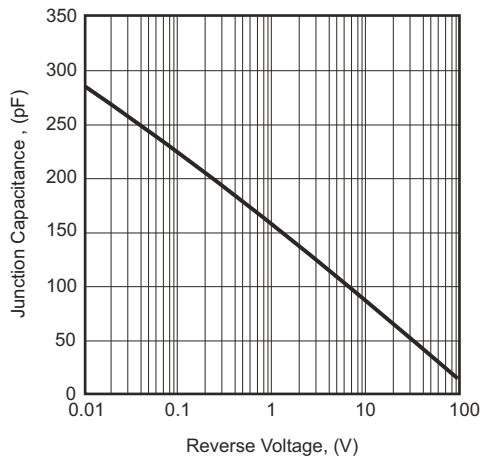

Fig.4A - Typical Reverse Characteristics (CDBW140R-HF)

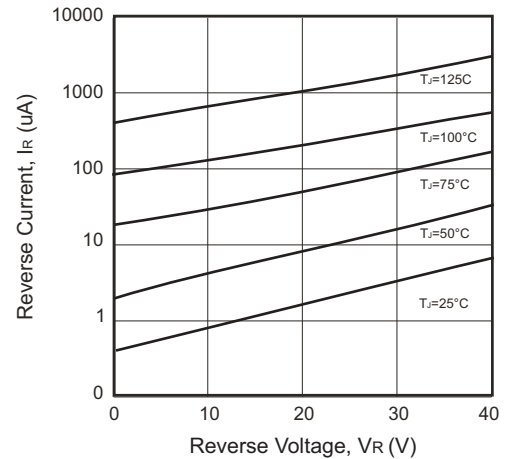

Fig.4B - Typical Reverse Characteristics (CDBW160R-HF)

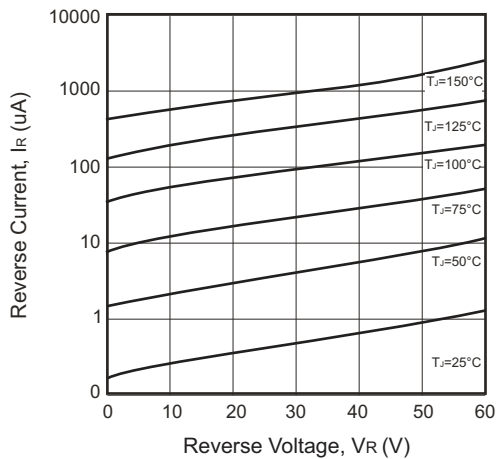
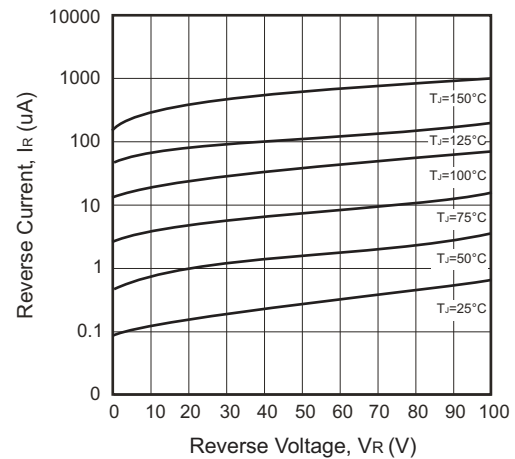

Fig.4C - Typical Reverse Characteristics (CDBW1100R-HF)



Company reserves the right to improve product design, functions and reliability without notice.

REV: B

## Reel Taping Specification

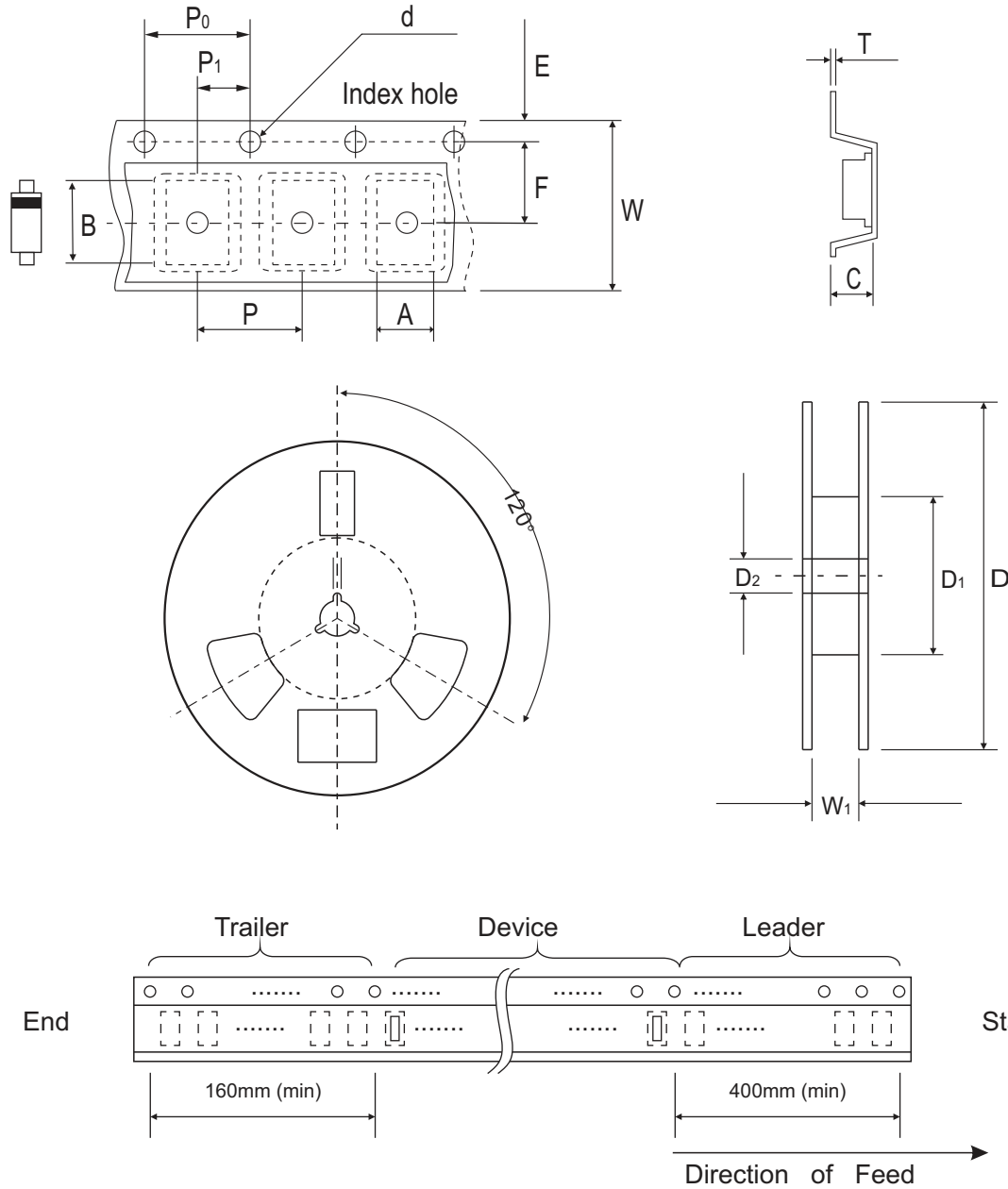

SOD-123	SYMBOL	A	B	C	d	D	D1	D2
	(mm)	1.85 ± 0.10	3.94 ± 0.10	1.57 ± 0.10	1.55 + 0.05	178 ± 1.00	54.0 ± 0.50	13.0 ± 0.50
	(inch)	0.073 ± 0.004	0.155 ± 0.004	0.062 ± 0.004	0.061 + 0.002	7.008 ± 0.039	2.126 ± 0.020	0.512 ± 0.020

SOD-123	SYMBOL	E	F	P	P0	P1	W	W1
	(mm)	1.75 ± 0.10	3.50 ± 0.05	4.00 ± 0.10	4.00 ± 0.10	2.00 ± 0.05	8.00+0.20/-0.10	9.50 ± 1.00
	(inch)	0.069 ± 0.004	0.138 ± 0.002	0.158 ± 0.004	0.158 ± 0.004	0.079 ± 0.002	0.315+0.008/-0.004	0.374 ± 0.039

Company reserves the right to improve product design, functions and reliability without notice.

REV: B

## Marking Code

Part Number	Marking Code
CDBW140R-HF	SL
CDBW160R-HF	SM
CDBW1100R-HF	SN



xx= Product type marking code

## Suggested PAD Layout

SIZE	SOD-123	
	(mm)	(inch)
A	1.22	0.048
B	0.91	0.036
C	2.36	0.093
D	4.19	0.165

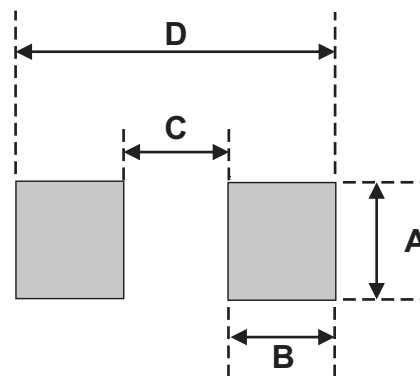

## Standard Packaging

Case Type	REEL PACK	
	REEL ( pcs )	Reel Size (inch)
SOD-123	3,000	7