

SEE DETAIL A

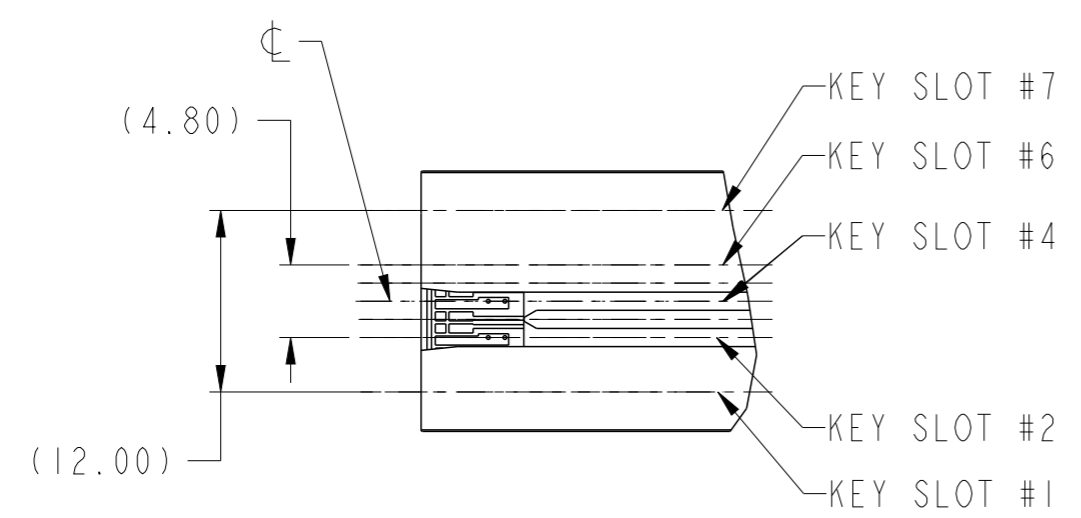

DETAIL A
 KEY SLOTS #2 & #4 SHOWN
 SCALE 2:1

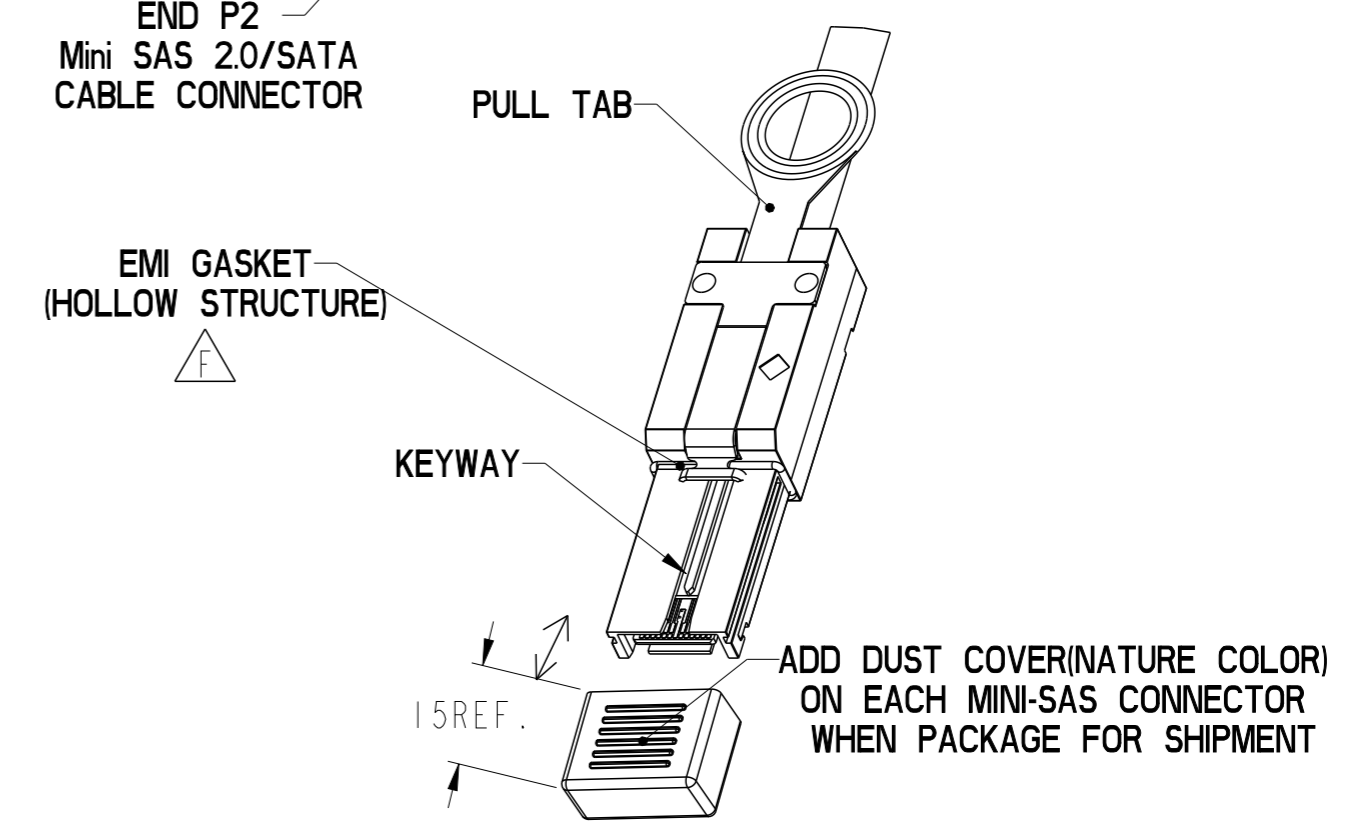

spec ref	---	dr	Deborah Ingram	2010/09/01	projection	MM	size	A3	scale	1:1
tolerance std	---	eng	Tom Feng	2014/09/23			ecn no	ELX-N-18515-1	rel level	Released
---	TOLERANCES UNLESS OTHERWISE SPECIFIED	chr	-	---						
surface	✓	appr	Delhy Liu	2014/09/24			dwg no	10115796	rev	G
---	linear	0.X	±0.3	www.fci.com	cat. no.	-	Product - Customer Drw	sheet 1 of 6		
		0.XX	±0.10							
		0.XXX	±0.050							
	angular	0°	±2°							

MINI SAS 2.0

PRODUCT NUMBER SEE NOTE 4	HUAWEI PART NUMBER	DESCRIPTION	GAUGE	"DIM L" LENGTH	END P1 KEY SLOT	END P2 KEY SLOT	IDENTIFIER
10115796-M060002LF	/	X4 SAS CABLE ASSEMBLY	24 AWG	6M	4, 6	4, 6	SUBSTRACTIVE ROUTING (IN PORT), SAS
10115796-N040002LF	/	X4 SAS CABLE ASSEMBLY	26 AWG	4M	4, 6	4, 6	
10115796-N050002LF	/	X4 SAS CABLE ASSEMBLY	26 AWG	5M	4, 6	4, 6	
10115796-P010002LF	/	X4 SAS CABLE ASSEMBLY	28 AWG	1M	4, 6	4, 6	
10115796-P020002LF	/	X4 SAS CABLE ASSEMBLY	28 AWG	2M	4, 6	4, 6	
10115796-P030002LF	/	X4 SAS CABLE ASSEMBLY	28 AWG	3M	4, 6	4, 6	
10115796-M060003LF	/	X4 SAS CABLE ASSEMBLY	24 AWG	6M	2, 4, 6	2, 4, 6	UNIVERSAL KEY, SAS
10115796-N040003LF	/	X4 SAS CABLE ASSEMBLY	26 AWG	4M	2, 4, 6	2, 4, 6	
10115796-N050003LF	/	X4 SAS CABLE ASSEMBLY	26 AWG	5M	2, 4, 6	2, 4, 6	
10115796-P003803LF	/	X4 SAS CABLE ASSEMBLY	28 AWG	0.38M	2, 4, 6	2, 4, 6	
10115796-P004003LF	/	X4 SAS CABLE ASSEMBLY	28 AWG	0.4M	2, 4, 6	2, 4, 6	
10115796-P004603LF	/	X4 SAS CABLE ASSEMBLY	28 AWG	0.46M	2, 4, 6	2, 4, 6	
10115796-P004803LF	/	X4 SAS CABLE ASSEMBLY	28 AWG	0.48M	2, 4, 6	2, 4, 6	
10115796-P005003LF	/	X4 SAS CABLE ASSEMBLY	28 AWG	0.5M	2, 4, 6	2, 4, 6	
10115796-P010003LF	0405G002	X4 SAS CABLE ASSEMBLY	28 AWG	1M	2, 4, 6	2, 4, 6	
10115796-P015003LF	/	X4 SAS CABLE ASSEMBLY	28 AWG	1.5M	2, 4, 6	2, 4, 6	
10115796-P020003LF	/	X4 SAS CABLE ASSEMBLY	28 AWG	2M	2, 4, 6	2, 4, 6	
10115796-P025003LF	/	X4 SAS CABLE ASSEMBLY	28 AWG	2.5M	2, 4, 6	2, 4, 6	
10115796-P030003LF	0405G004	X4 SAS CABLE ASSEMBLY	28 AWG	3M	2, 4, 6	2, 4, 6	
10115796-M060006LF	/	X4 SAS CABLE ASSEMBLY	24 AWG	6M	2, 4	4, 6	
10115796-N040006LF	/	X4 SAS CABLE ASSEMBLY	26 AWG	4M	2, 4	4, 6	
10115796-N050006LF	/	X4 SAS CABLE ASSEMBLY	26 AWG	5M	2, 4	4, 6	
10115796-P007106LF	/	X4 SAS CABLE ASSEMBLY	28 AWG	0.71M	2, 4	4, 6	
10115796-P010006LF	/	X4 SAS CABLE ASSEMBLY	28 AWG	1M	2, 4	4, 6	
10115796-P015006LF	/	X4 SAS CABLE ASSEMBLY	28 AWG	1.5M	2, 4	4, 6	
10115796-P020006LF	/	X4 SAS CABLE ASSEMBLY	28 AWG	2M	2, 4	4, 6	
10115796-P030006LF	/	X4 SAS CABLE ASSEMBLY	28 AWG	3M	2, 4	4, 6	

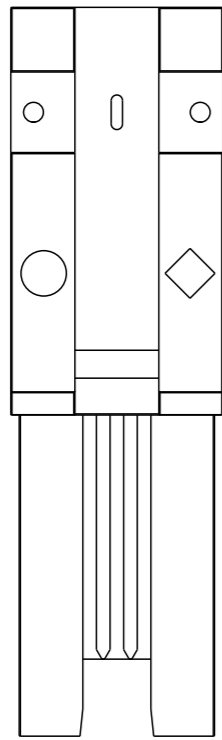

KEY SLOT 2, 4 & 6
○◇ UNIVERSAL PORT

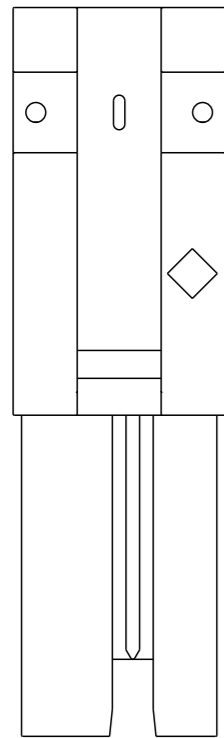

KEY SLOT 2 & 4
◇ OUT PORT

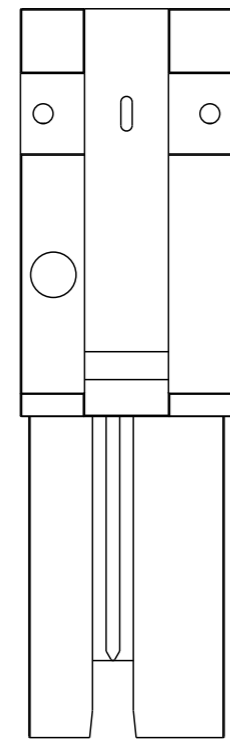

KEY SLOT 4 & 6
○ IN PORT

MINI SAS 2.0 KEYING OPTIONS

spec ref	---	dr	Deborah Ingram	2010/09/01	projection	MM	size	A3	scale	1:1
tolerance std	---	eng	Tom Feng	2014/09/23			ecn no	ELX-N-18515-1	rel level	Released
---	TOLERANCES UNLESS OTHERWISE SPECIFIED	chr	-	-						
---		appr	Delhly Liu	2014/09/24	product family	C&A				
surface	✓	linear	0.X	±0.3		FINAL ASSEMBLY - STANDARD Mini SAS 2.0/SATA	dwg no	10115796	rev	G
			0.XX	±0.10						
			0.XXX	±0.050						
		angular	0°	±2°	www.fci.com	cat. no.	-	Product - Customer Drw	sheet 2 of 6	

SATA

PRODUCT NUMBER SEE NOTE 4	DESCRIPTION	GAUGE	"DIM L" LENGTH	END P1 KEY SLOT	END P2 KEY SLOT	IDENTIFIER
10115796-M060004LF	X4 SATA CABLE ASSEMBLY	24 AWG	6M	1,4	1,4	X CABLE, SATA
10115796-N020004LF	X4 SATA CABLE ASSEMBLY	26 AWG	2M	1,4	1,4	
10115796-N040004LF	X4 SATA CABLE ASSEMBLY	26 AWG	4M	1,4	1,4	
10115796-N050004LF	X4 SATA CABLE ASSEMBLY	26 AWG	5M	1,4	1,4	
10115796-P010004LF	X4 SATA CABLE ASSEMBLY	28 AWG	1M	1,4	1,4	
10115796-P030004LF	X4 SATA CABLE ASSEMBLY	28 AWG	3M	1,4	1,4	
10115796-M060005LF	X4 SATA CABLE ASSEMBLY	24 AWG	6M	7	7	M CABLE, SATA
10115796-N020005LF	X4 SATA CABLE ASSEMBLY	26 AWG	2M	7	7	
10115796-N040005LF	X4 SATA CABLE ASSEMBLY	26 AWG	4M	7	7	
10115796-N050005LF	X4 SATA CABLE ASSEMBLY	26 AWG	5M	7	7	
10115796-P010005LF	X4 SATA CABLE ASSEMBLY	28 AWG	1M	7	7	
10115796-P030005LF	X4 SATA CABLE ASSEMBLY	28 AWG	3M	7	7	

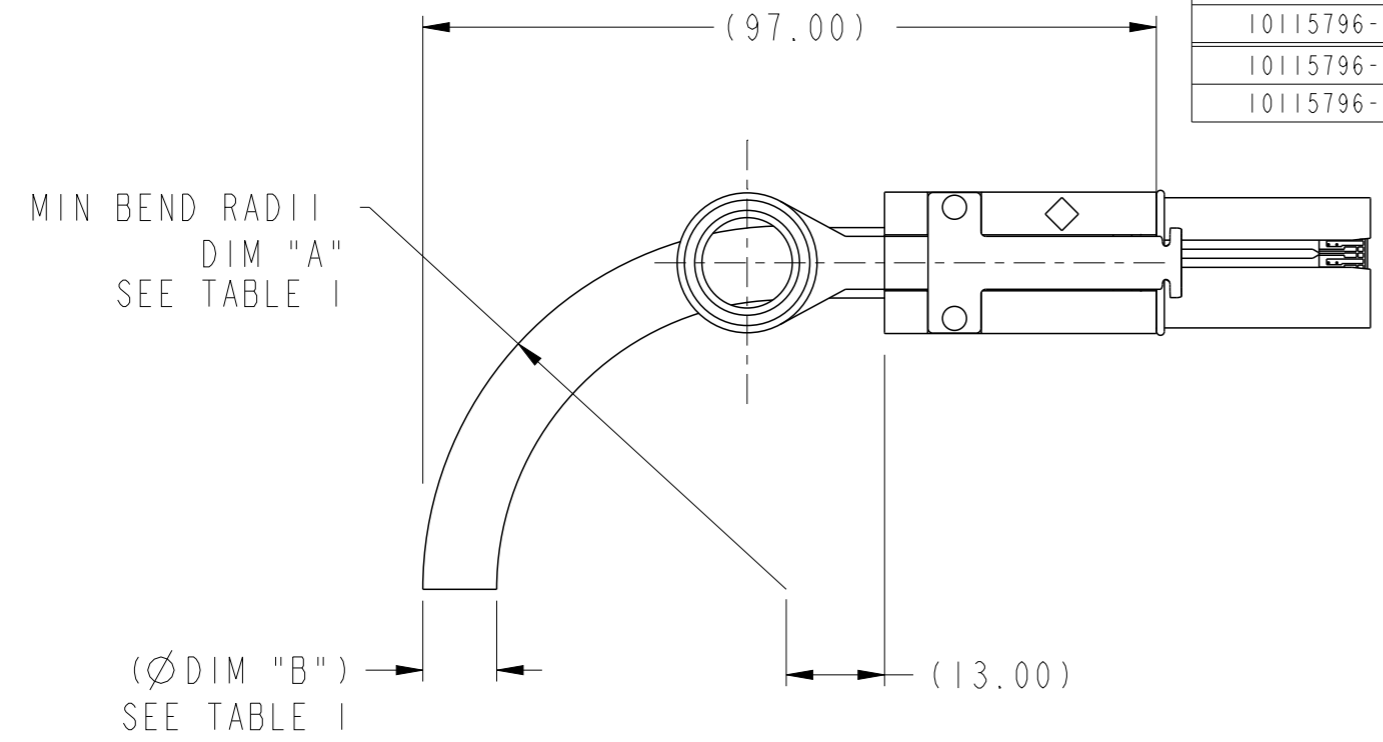

**BEND RADIUS
(24 AWG SHOWN)**

CABLE	DIM "A"	DIM "B"
24 AWG	TBD	TBD
26 AWG	TBD	TBD
28 AWG	TBD	TBD

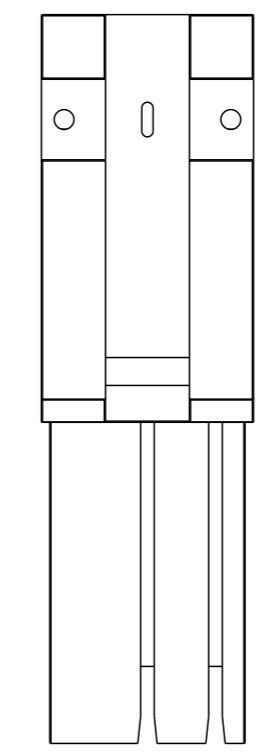

KEY SLOT 1 & 4
X CABLE, SATA

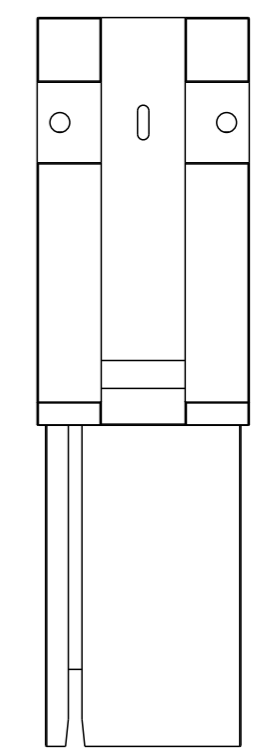

KEY SLOT 7
M CABLE, SATA

SATA KEYING OPTIONS

spec ref	---	dr	Deborah Ingram	2010/09/01	projection	MM	size	A3	scale	1:1
tolerance std	---	eng	Tom Feng	2014/09/23			ecn no	ELX-N-18515-1	rel level	Released
---	TOLERANCES UNLESS OTHERWISE SPECIFIED	chr	-	-						
surface	✓	appr	Delhly Liu	2014/09/24	product family	C&A	rel level	Released	rev	G
linear	0.X ±0.3			title	FINAL ASSEMBLY - STANDARD		dwg no	10115796		
	0.XX ±0.10	www.fci.com		cat. no.	-		Product - Customer Drw	sheet 3 of 6		
	0.XXX ±0.050									
angular	0° ±2°									

A

B

C

D

A

B

C

D

WIRING LIST SEE NOTE 7

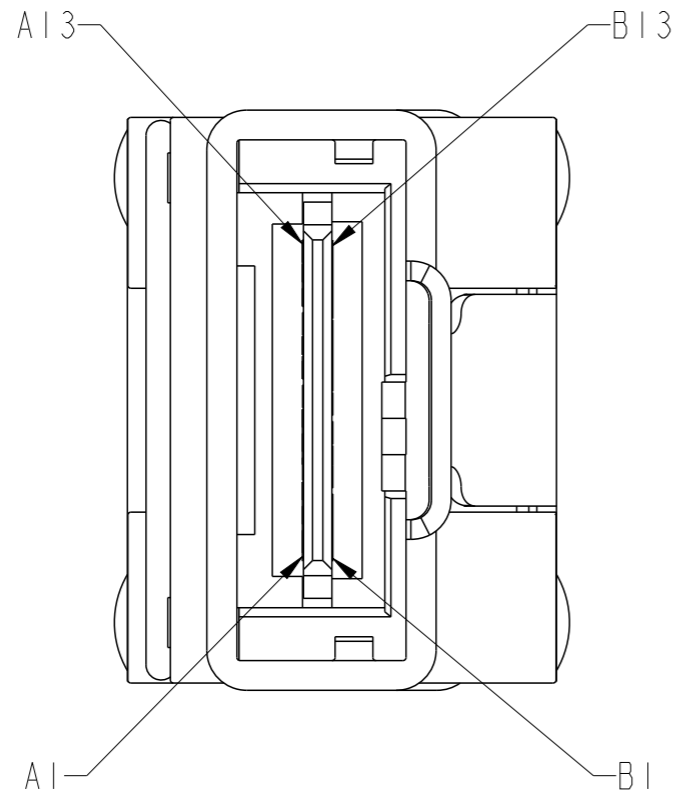

	GND	A1	—	B1	GND
	Rx 0+	A2	←	B2	Tx 0+
	Rx 0-	A3	←	B3	Tx 0-
	GND	A4	—	B4	GND
	Rx 1+	A5	←	B5	Tx 1+
	Rx 1-	A6	←	B6	Tx 1-
	GND	A7	—	B7	GND
	Rx 2+	A8	←	B8	Tx 2+
	Rx 2-	A9	←	B9	Tx 2-
	GND	A10	—	B10	GND
	Rx 3+	A11	←	B11	Tx 3+
	Rx 3-	A12	←	B12	Tx 3-
	GND	A13	—	B13	GND
P1	GND	B1	—	A1	GND
	Tx 0+	B2	→	A2	Rx 0+
	Tx 0-	B3	→	A3	Rx 0-
	GND	B4	—	A4	GND
	Tx 1+	B5	→	A5	Rx 1+
	Tx 1-	B6	→	A6	Rx 1-
	GND	B7	—	A7	GND
	Tx 2+	B8	→	A8	Rx 2+
	Tx 2-	B9	→	A9	Rx 2-
	GND	B10	—	A10	GND
	Tx 3+	B11	→	A11	Rx 3+
	Tx 3-	B12	→	A12	Rx 3-
	GND	B13	—	A13	GND
					P2



Copyright FCI.

spec ref	---	dr	Deborah Ingram	2010/09/01	projection	MM	size	A3	scale	4:1									
tolerance std	---	eng	Tom Feng	2014/09/23			ecn no	ELX-N-18515-1											
---	TOLERANCES UNLESS OTHERWISE SPECIFIED	chr	-	-				product family	C&A	rel level	Released								
surface	✓	appr	Delhy Liu	2014/09/24			dwg no	10115796		rev									
---	linear	<table border="1"> <tr><td>0.X</td><td>±0.3</td></tr> <tr><td>0.XX</td><td>±0.10</td></tr> <tr><td>0.XXX</td><td>±0.050</td></tr> </table>		0.X	±0.3	0.XX		±0.10	0.XXX	±0.050	<table border="1"> <tr><td>0°</td><td>±2°</td></tr> </table>	0°	±2°	<table border="1"> <tr><td>www.fci.com</td><td>cat. no.</td><td>-</td></tr> </table>	www.fci.com	cat. no.	-	Product - Customer Drw	sheet 4 of 6
0.X	±0.3																		
0.XX	±0.10																		
0.XXX	±0.050																		
0°	±2°																		
www.fci.com	cat. no.	-																	

NOTES:

- 1 - MATERIAL:
 BACKSHELLS: ZINC DIECAST
 PULL TAB: MOLDED THERMOPLASTIC
 LATCH: STAINLESS STEEL
 JET MELT: POLYAMIDE POLYMER
- 2 - ELECTRICAL PERFORMANCE PER CURRENT REVISION OF SERIAL ATA, T10/I760-D (SAS-2 REQUIREMENTS).
- ③ - THIS PRODUCT MEETS THE RESTRICTION OF HAZARDOUS SUBSTANCES IN ELECTRICAL AND ELECTRONIC EQUIPMENT (ROHS) DIRECTIVE (2011/65/EU)

4 - PART NUMBER DESCRIPTION

10115796 - X XX XX XX LF

LEAD FREE (SEE NOTE 3 AND 10)

KEY SLOT

- 01: KEY SLOT 2,4
- 02: KEY SLOT 4,6
- 03: KEY SLOT 2,4,6
- 04: KEY SLOT 1,4
- 05: KEY SLOT 7
- 06: P1= KEY SLOT 2,4 P2= KEY SLOT 4,6

LENGTH

XX= METERS, XX=CENTIMETERS
 0100 = 01 METERS, 00 CENTIMETERS ("DIM L")

GAUGE

- M: 24 AWG
- N: 26 AWG
- P: 28 AWG

⑤ - UNLESS OTHERWISE SPECIFIED ASSEMBLED LENGTH TOLERANCE IS TO BE:

- < 1 METER = ±25.0mm
- >= 1 METER TO 6 METERS = ± 2% OF "DIM L"



Copyright FCI.

spec ref	---	dr	Deborah Ingram	2010/09/01	projection	MM	size	A3	scale	1:1	
tolerance std	---	eng	Tom Feng	2014/09/23			ecn no		ELX-N-18515-1		
---	TOLERANCES UNLESS OTHERWISE SPECIFIED	chr	-	-			product family		C&A		rel level
surface	✓	appr	Delhy Liu	2014/09/24				title FINAL ASSEMBLY - STANDARD Mini SAS 2.0/SATA		dwg no 10115796 rev G	
---	linear	0.X ±0.3		www.fci.com		cat. no.		-		Product - Customer Drw	sheet 5 of 6
		0.XX ±0.10									
		0.XXX ±0.050									
	angular	0° ±2°									

NOTES CONTINUED:

⑥ - UNLESS OTHERWISE SPECIFIED LABEL POSITION IS TO BE 100mm FROM REAR OF CONNECTOR.
 LABEL DETAILS:

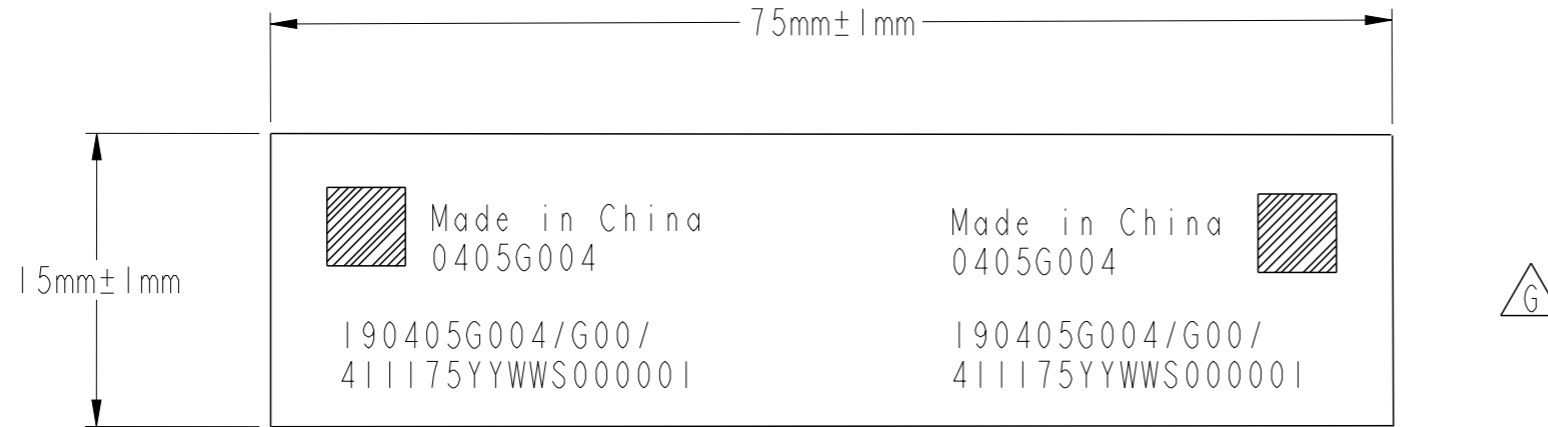

- ⑦ - ALL CABLE ASSEMBLIES SHALL BE 100% TESTED FOR CONTINUITY AS DEFINED IN WIRING LIST.
- 8 - UNLESS OTHERWISE SPECIFIED ALL CABLE ASSEMBLIES SHALL BE 100% HI-POT TESTED BY APPLYING 300V DC FOR A MINIMUM OF 10ms, UNLESS ACTIVE COMPONENTS ARE USED IN THIS ASSEMBLY.
- 9 - OTHER TESTING PERFORMED AS REQUIRED BY PRODUCT SPECIFICATION: GS-12-548.
- 10 - PACKAGING OF LEAD FREE PRODUCTS MEETS LABELING AND PACKAGING PER SPECIFICATION GS-14-920. PACKAGE CABLE ASSEMBLIES PER GS-14-1272. ADD DUST COVER ON MINI-SAS CONNECTOR WHEN PACKAGE FOR SHIPMENT NEED STICK BELOW LABEL ON PE BAG.

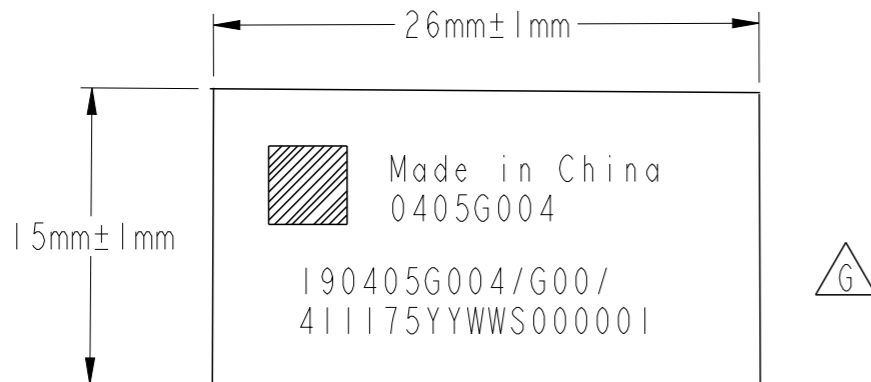

11. THIS DIMENSION IS A FINISHED PRODUCT LENGTH.

spec ref	---	dr	Deborah Ingram	2010/09/01	projection	MM	size	A3	scale	1:1
tolerance std	---	eng	Tom Feng	2014/09/23			ecn no		ELX-N-18515-1	
---	TOLERANCES UNLESS OTHERWISE SPECIFIED	chr	-	-			rel level		Released	
surface	✓	appr	Delhy Liu	2014/09/24	product family	C&A	rel level		Released	
---	linear			title	FINAL ASSEMBLY - STANDARD		dwg no	10115796		rev
	0.X	±0.3		www.fci.com	Mini SAS 2.0/SATA					G
	0.XX	±0.10		cat. no.	-		Product - Customer Drw		sheet 6 of 6	
	0.XXX	±0.050								
	angular	0° ±2°								