

MATERIAL NUMBER	ALTERNATE NUMBER	"S"	WIRE RANGE	COLOR	PACKAGING
190570007	A-521-06	.146/3.70	22-18 AWG	RED	LOOSE PIECE
190570009	A-521-08	.173/4.39	22-18 AWG	RED	
190570011	A-521-10	.198/5.02	22-18 AWG	RED	
190570008	A-521-06T	.146/3.70	22-18 AWG	RED	TAPE
190570010	A-521-08T	.173/4.39	22-18 AWG	RED	
190570012	A-521-10T	.198/5.02	22-18 AWG	RED	

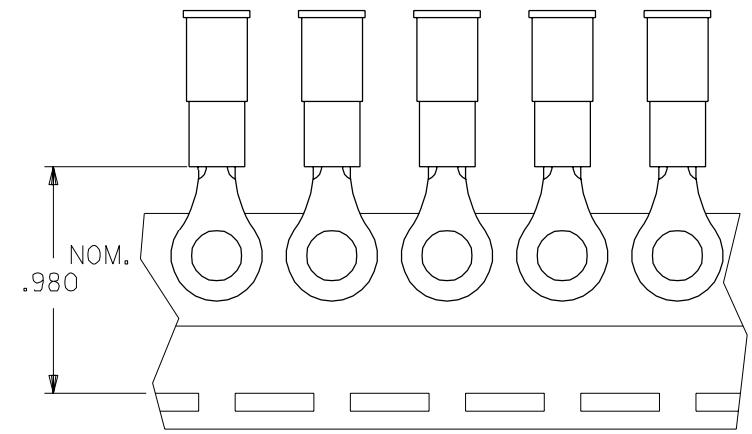
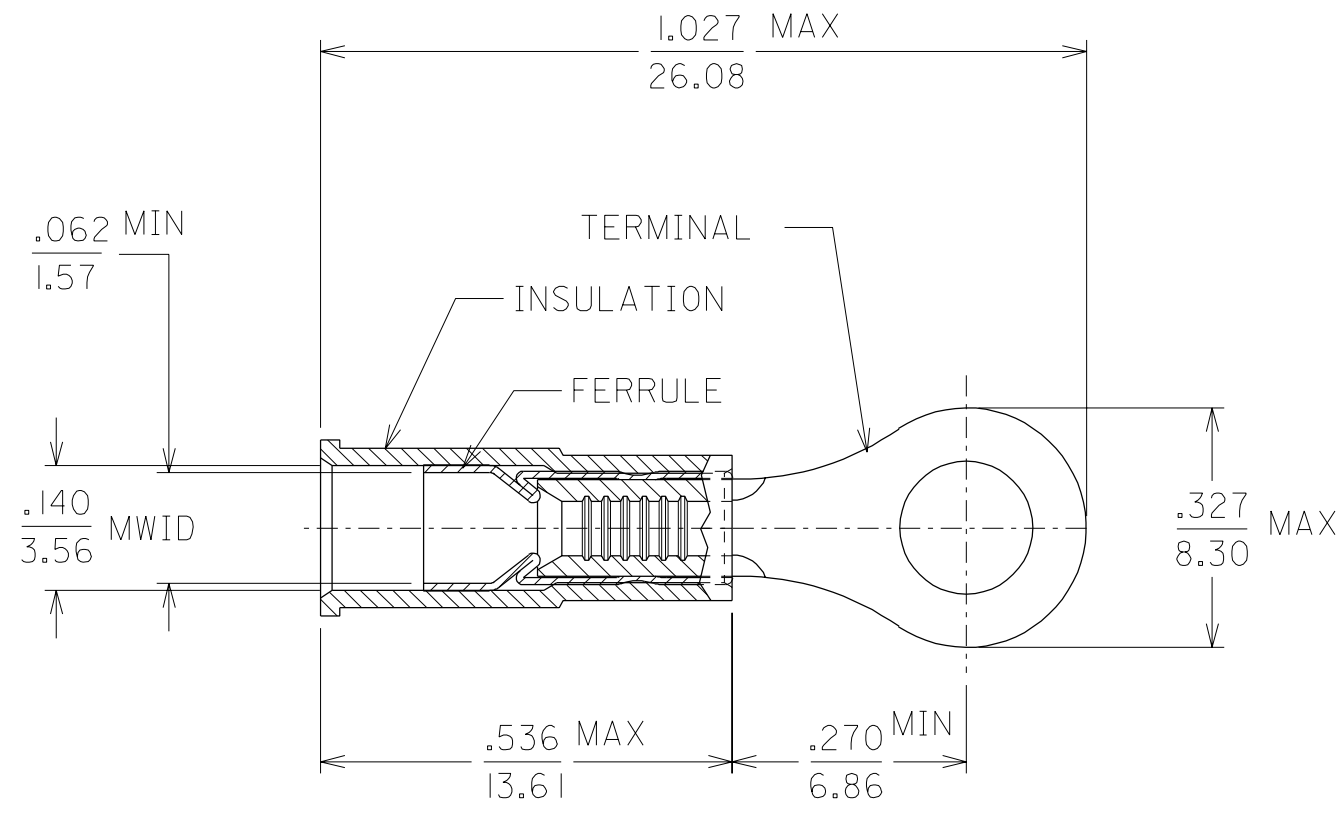

- MATERIAL: TERMINAL: COPPER
.028/.711 THICK.
FUNNEL FERRULE: BRASS
PLATING: ELECTRO TIN
INSULATION: NYLON 6/6
COLOR: SEE CHART
- MWID = MAXIMUM WIRE INSULATION DIAMETER
- ALL DIMENSIONS = INCHES / MM

CUSTOMER DRAWING

A	NEW CUST. DWG. ETC2001-0288 01/03/23 EDB
LTR.	REVISIONS

DIMENSIONS SHOWN (METRIC) INCH		REVISE ONLY ON CAD SYSTEM																			
UNLESS OTHERWISE SPECIFIED TOLERANCES: ANGULAR ± 1/2°		TITLE RING TONGUE TERMINAL AVIKRIMP 500 SERIES																			
<table border="1"> <thead> <tr> <th></th> <th>INCH</th> <th>METRIC</th> </tr> </thead> <tbody> <tr> <td>3 PLACE</td> <td>± .005</td> <td>± ---</td> </tr> <tr> <td>2 PLACE</td> <td>± .01</td> <td>± 0.13</td> </tr> <tr> <td>1 PLACE</td> <td>± ---</td> <td>± 0.25</td> </tr> </tbody> </table>			INCH	METRIC	3 PLACE	± .005	± ---	2 PLACE	± .01	± 0.13	1 PLACE	± ---	± 0.25	<table border="1"> <tr> <td>molex ETC INC.</td> <td>SHEET NO.</td> <td>DATE</td> </tr> <tr> <td>PINELLAS PARK, FLA. 33781 U.S.A.</td> <td>1 OF 1</td> <td>01/03/23</td> </tr> </table>		molex ETC INC.	SHEET NO.	DATE	PINELLAS PARK, FLA. 33781 U.S.A.	1 OF 1	01/03/23
	INCH	METRIC																			
3 PLACE	± .005	± ---																			
2 PLACE	± .01	± 0.13																			
1 PLACE	± ---	± 0.25																			
molex ETC INC.	SHEET NO.	DATE																			
PINELLAS PARK, FLA. 33781 U.S.A.	1 OF 1	01/03/23																			
DRAFT WHERE APPLICABLE MUST REMAIN WITHIN DIMENSIONS		PART NO. SEE TABLE																			
DRWG. BY: EDB		DRWG. NO. SD-19057-002																			
CHK'D. BY: HEB		FILE NAME SD19057002																			
APP'D. BY: RWD		SCALE: NO: NE																			
		THIS DRAWING CONTAINS INFORMATION THAT IS PROPRIETARY TO MOLEX-ETC INC. AND SHOULD NOT BE USED WITHOUT WRITTEN PERMISSION.																			
		DIV. ET																			
		SIZE B																			