



# BNC75 Series

## 12G-SDI standard compliant, 75Ω, RF Connector

### ◆ Features

1. 3G/6G/12G-SDI standard compliant, BNC 75Ω connector
2. Optimized mounting area design and internal structure to realize 12Gbps transmission
3. Simplified PCB layout
4. RoHS compliant

### ◆ Dimensions

- Thread-fastened type  
BNC(75)-PLR-PC-12G-1

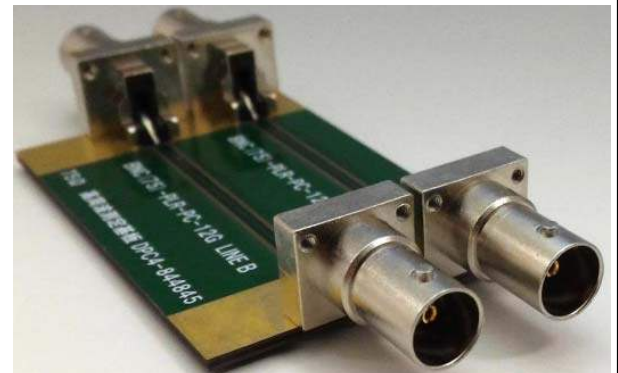
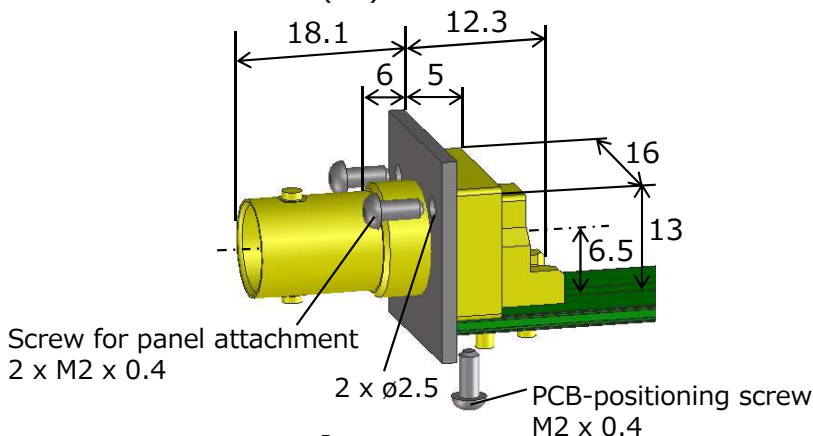

- Bulkhead type  
BNC(75)-BLR-PC-12G

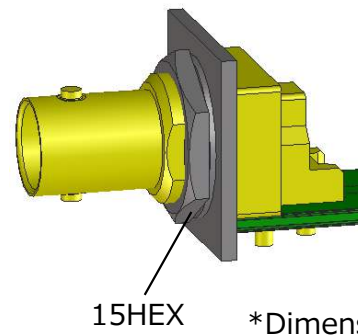

### ◆ Space saving

Example: FA camera

Supports image data transmission equivalent to 12Gbps through a single line specified in the 12G-SDI standard.

**3G-SDI connector**

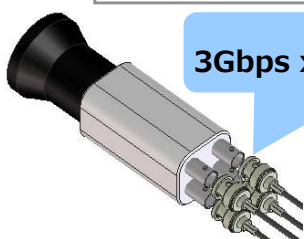

Requires  
3Gbps x 4 BNC connectors

**12G-SDI connector**

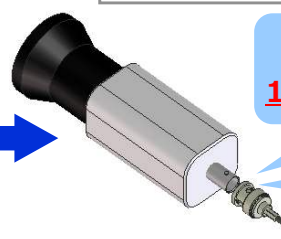

Integrates required  
connectors into  
**12Gbps x 1 BNC connector.**

**Space saving** of FA camera  
interface is realized.

### ◆ Specifications

Characteristic impedance	75Ω
Frequency range	0 to 12GHz
V.S.W.R.	1.29 Max. (0 to 3GHz) 1.43 Min. (3 to 12GHz)
Operating temperature	-40°C to +85°C
Insulation resistance	500V DC 1000MΩ Min.
Withstanding voltage	500V AC for 1 minute
Contact resistance	Center contact: 8mΩ Max. Outer contact: 8mΩ Max.
Durability	1000 times

Specifications herein are subject to change without notice. Contact Hirose for the latest specifications, drawings and availabilities.