

IN THE CONSTANT PURPOSE OF IMPROVING ITS PRODUCTS, AMPHENOL SOCAPEX RESERVES THE RIGHT TO MODIFY ANY DIMENSION OR CHARACTERISTICS.
FM.NPD.0036.THYEZ.PUNE rev C

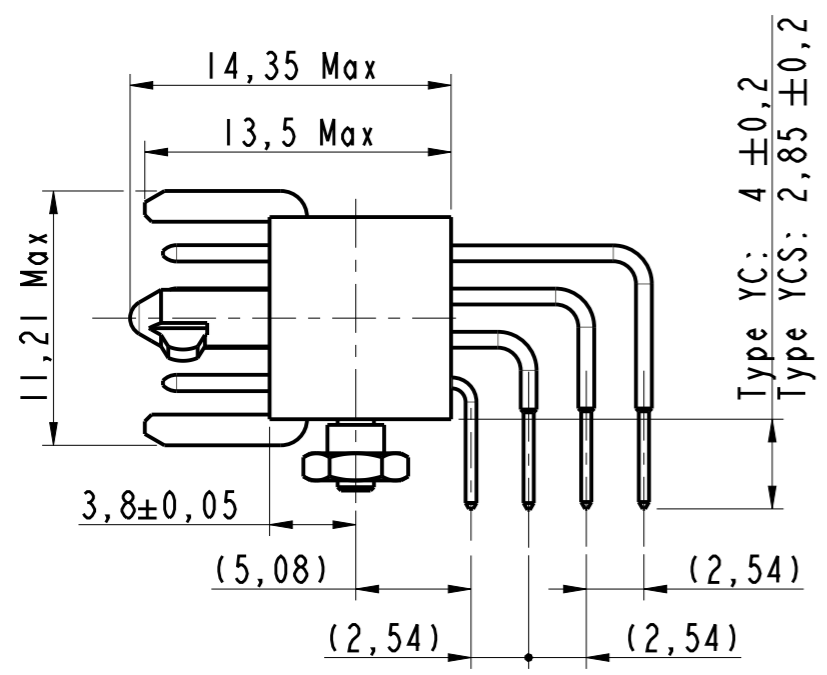

Type YC: 4 ±0,2
Type YCS: 2,85 ±0,2

Tinning: deviation XIX
2 Min For YCS
3 Min for YC

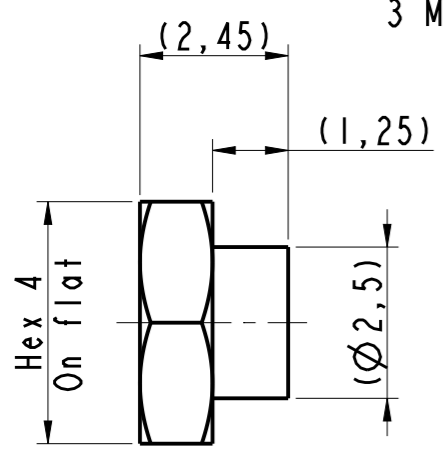

Shoulder nut
Scale 8

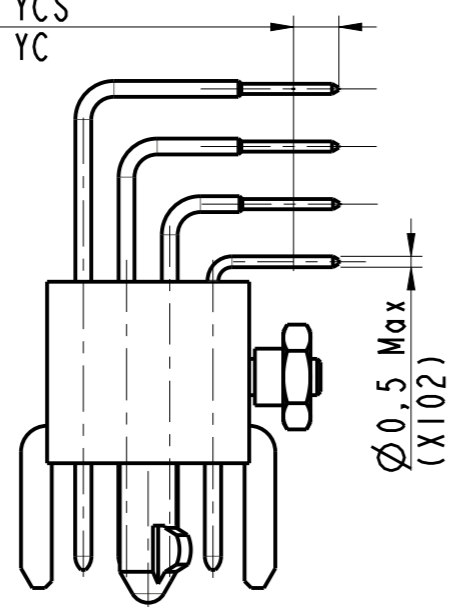

Rows
d
c
b
a

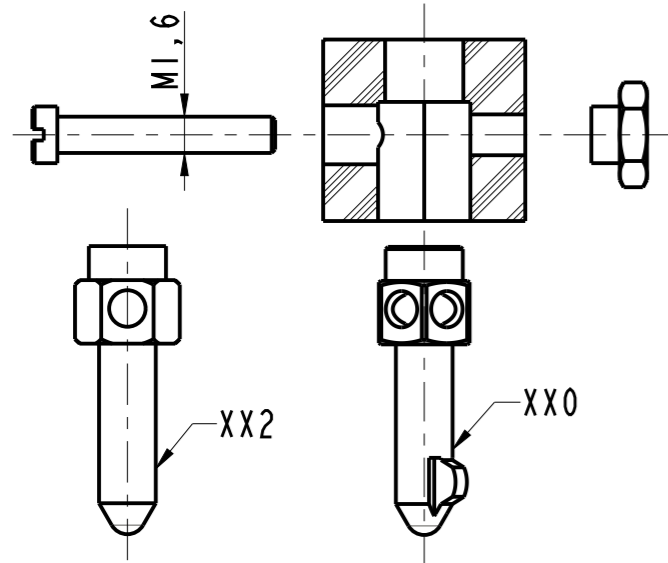

Uncoding guide
Coding guide
Section A-A

Notes:

- Part: HDAS F 102 YCX-XXX XX
- External dimensions for a male plug with 102 signal contacts type YCX
- Connector delivered with fittings not assembled, coupling torque : 0,15Nm
- Standard OXX : Nickel plated over brass fittings.
Deviation IXX : Passivated stainless steel fittings.
- Standard XOX : Contacts gold plated (RoHS)
Deviation XIX : Contacts tail Hot dip tinned SnPb (non RoHS) or SnAg (RoHS)

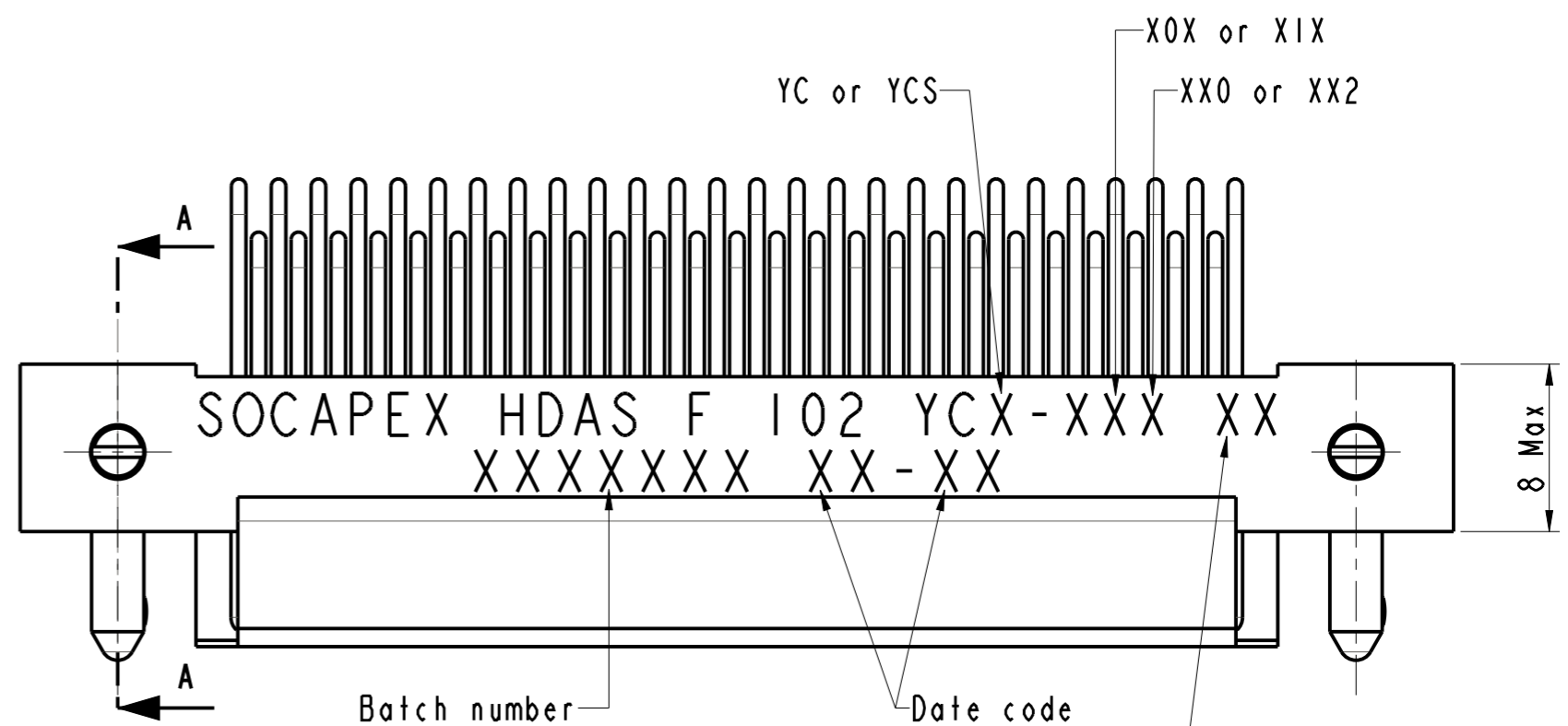
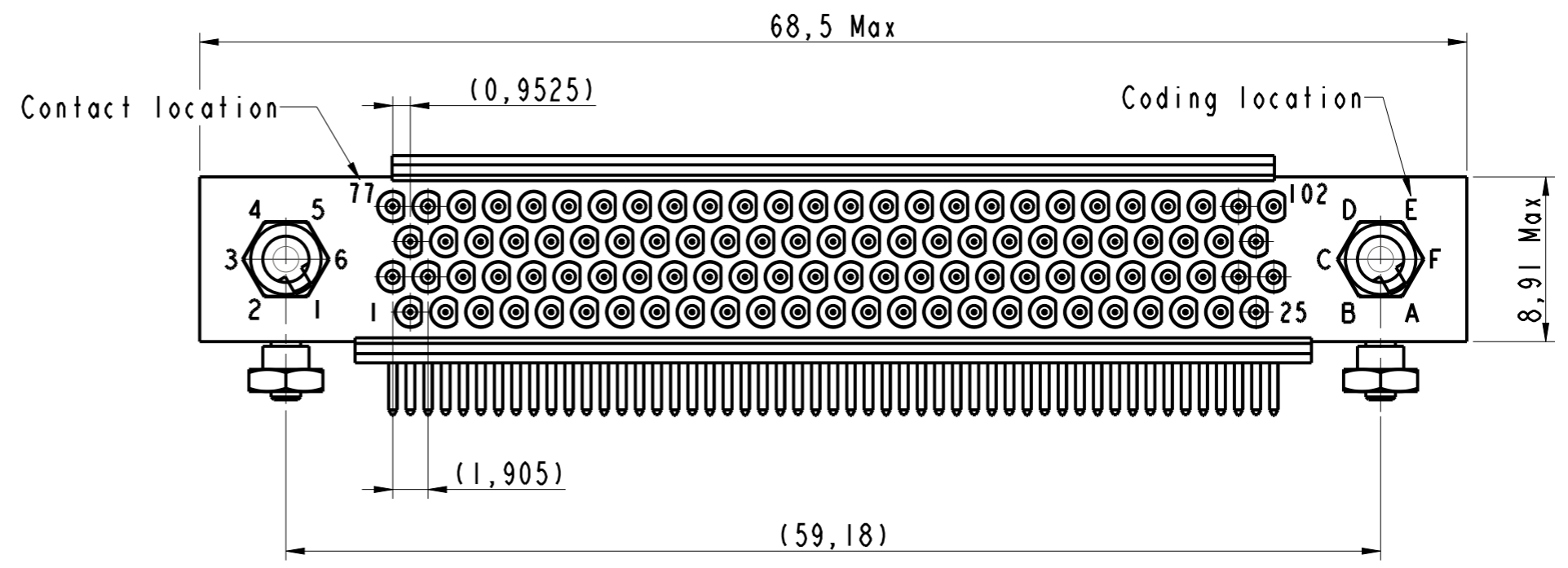

LF (SnAg bright tinning) or nothing (SnPb tinning)

HDAS F 102 YCX-XXX XX

DRAWN BY: S Satpute		UPDATED BY: S Satpute		LAST APPROVED BY: T Carrier	
ALL DIMENSIONS ARE IN MM	AMPHENOL SOCAPEX			ORIGINAL DRAWING DATE: 03/09/2019	CONFIGURATION DATA ARE AVAILABLE IN PDM
				REV: D	PAGE: 1/2
SCALE: 3	B.P. 29 74311 THYEZ CEDEX			169-PLC-1327-00	

PCB Layout
Face A

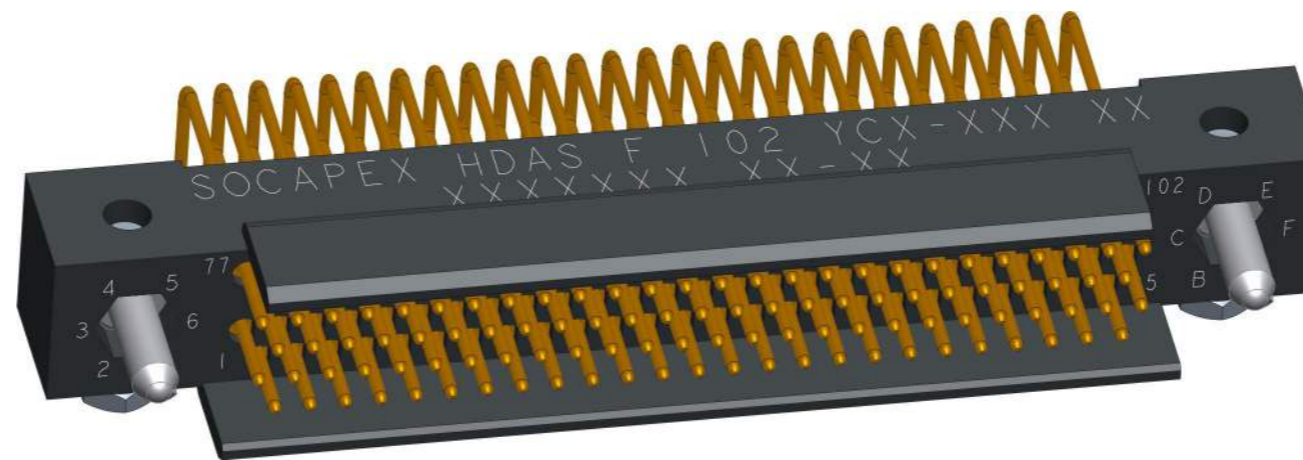
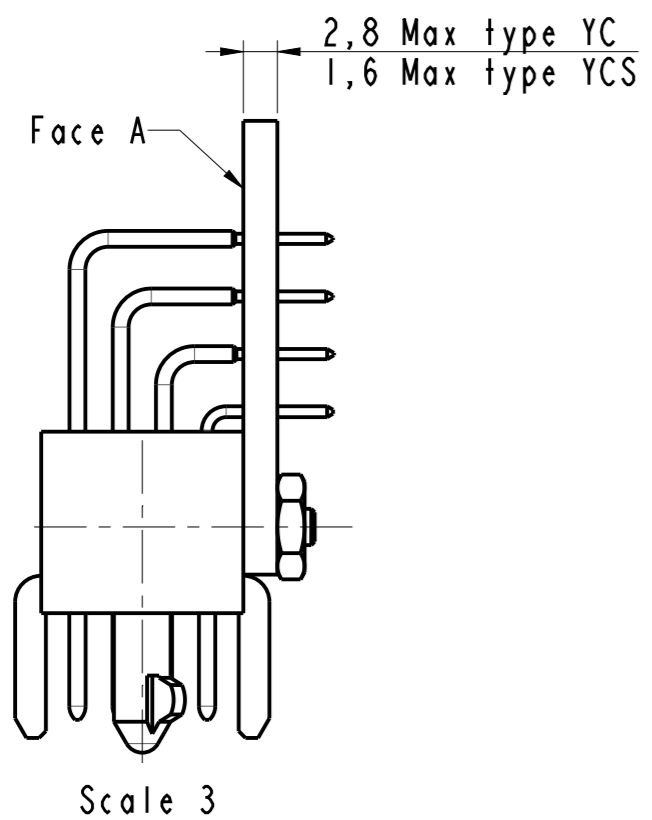
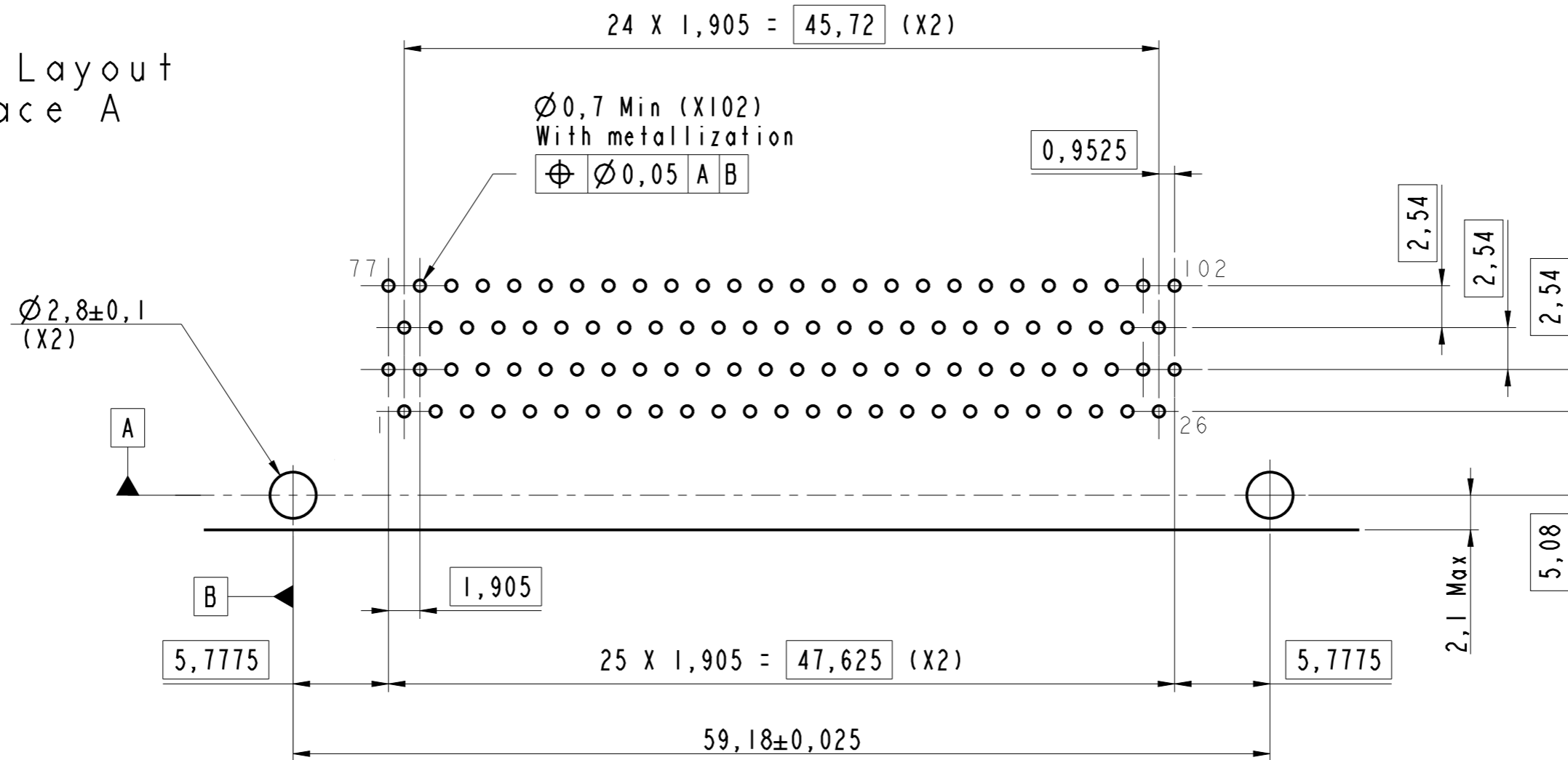

Scale 2,5

HDAS F 102 YCX-XXX XX

DRAWN BY : S Satpute		UPDATED BY : S Satpute		LAST APPROVED BY : T Carrier	
ALL DIMENSIONS ARE IN MM		AMPHENOL SOCAPEX		ORIGINAL DRAWING DATE : 03/09/2019	CONFIGURATION DATA ARE AVAILABLE IN PDM
SCALE : 3				REV : D	PAGE : 2/2
		B.P. 29 74311 THYEZ CEDEX		169-PLC-1327-00	

IN THE CONSTANT PURPOSE OF IMPROVING ITS PRODUCTS, Amphenol Socapex RESERVES THE RIGHT TO MODIFY ANY DIMENSION OR CHARACTERISTICS.
 FM.NPD.0036.THYEZ.PUNE rev C