

## FEATURES

- DC-5500 MHz Operation Bandwidth
- +42 dBm Output IP3 at 850 MHz
- 5 dB Noise Figure at 850 MHz
- 12 dB Gain at 850 MHz
- +17.5 dBm P1dB at 1950 MHz
- SOT-89 Package
- Single +8 V to +12 V Supply
- Case Temperature: -40 to +85 °C
- RoHS Compliant Package Option, 260 °C MSL-1

## APPLICATIONS

- Cellular Base Stations for W-CDMA, CDMA, TDMA, GSM, PCS and CDPD systems
- Fixed Wireless
- MMDS/WLL
- WLAN, HyperLAN

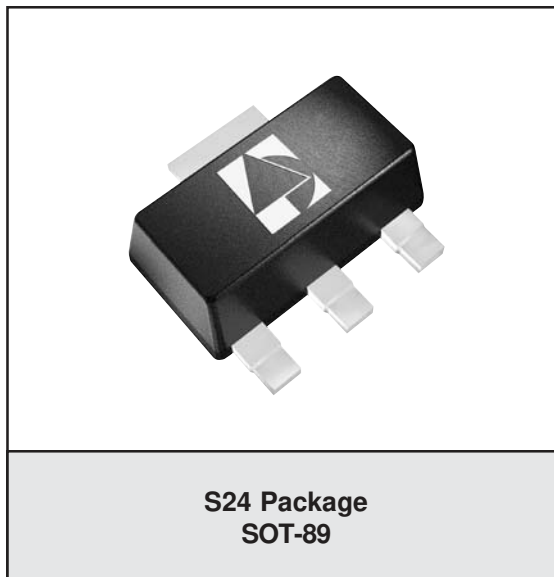

## PRODUCT DESCRIPTION

The AGB3307 is one of a series of high performance InGaP HBT amplifiers designed for use in applications requiring high linearity, low noise and low distortion. No external matching components are needed for insertion into a 50Ω system. With a high output IP3, low noise figure and wide band

operation, the AGB3307 is ideal for wireless infrastructure applications such as Cellular Base Stations, MMDS, and WLL. Offered in a low cost SOT-89 surface mount package, the AGB3307 requires a single supply voltage, and typically consumes 0.6 Watts of power using a +8 V supply.

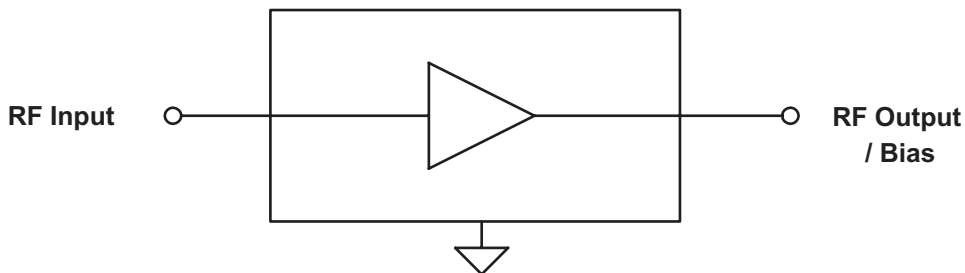
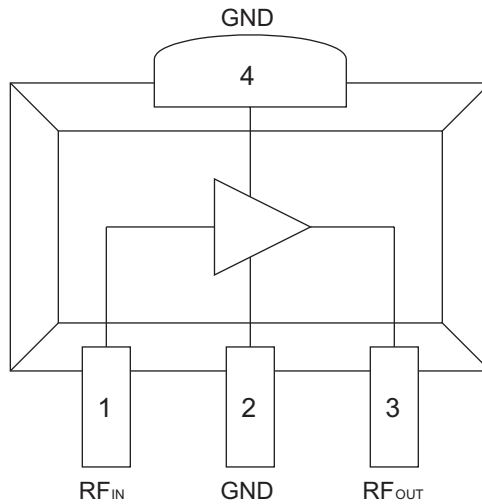

Figure 1: Block Diagram



**Figure 2: Pinout (X-ray Top View)**

**Table 1: Pin Description**

PIN	NAME	DESCRIPTION
1	RF <sub>IN</sub>	RF Input
2	GND	Ground
3	RF <sub>OUT</sub>	RF Output / Bias
4	GND	Ground

## ELECTRICAL CHARACTERISTICS

Table 2: Absolute Minimum and Maximum Ratings

PARAMETER	MIN	MAX	UNIT
Device Voltage ( $V_{CC}$ )	0	+6	VDC
RF Input Power ( $P_{IN}$ )	-	+10	dBm
Storage Temperature ( $T_{STG}$ )	-40	+150	°C
Junction Temperature	-	+200	°C

Stresses in excess of the absolute ratings may cause permanent damage. Functional operation is not implied under these conditions. Exposure to absolute ratings for extended periods of time may adversely affect reliability.

Table 3: Operating Ranges

PARAMETER	MIN	TYP	MAX	UNIT
Operating Frequency (f) <sup>(1)</sup>	-	-	5500	MHz
Supply Voltage ( $V_{SUPPLY}$ ) <sup>(2)</sup>	-	+8	-	VDC
Case Temperature ( $T_C$ )	-40	-	+85	°C

The device may be operated safely over these conditions; however, parametric performance is guaranteed only over the conditions defined in the electrical specifications.

Notes:

- (1) Operating frequency is defined by the output return loss (S22) having a VSWR less than 2:1.
- (2) Voltage applied through a bias resistor and inductor. Refer to Figure 3. For other supply voltages, see the APPLICATION INFORMATION section.

**Table 4: Electrical Specifications**  
 (T<sub>A</sub> = +25 °C, V<sub>SUPPLY</sub> = +8 VDC, 50Ω System)

PARAMETER	MIN	TYP	MAX	UNIT	
Gain (S <sub>21</sub> )	850 MHz	-	11.9	-	dB
	1950 MHz	-	11.7	-	
	2140 MHz	-	11.5	-	
	2450 MHz	-	11.5	-	
Output IP3 <sup>(1)</sup>	850 MHz	-	+41.9	-	dBm
	1950 MHz	-	+36.0	-	
	2140 MHz	-	+35.6	-	
	2450 MHz	-	+33.8	-	
Output 1dB Compression (P1dB)	1950 MHz	-	+17.4	-	dBm
Noise Figure	850 MHz	-	5	-	dB
Thermal Resistance (θ <sub>Jc</sub> ) <sup>(2)</sup>	-	140	-	°C/W	
Supply Current (I <sub>cc</sub> )	-	80	-	mA	

Notes:

- (1) OIP3 is measured with two tones at 1 MHz spacing at 0 dBm output power per tone.
- (2) The value for Thermal Resistance is based on a Device Voltage (V<sub>cc</sub>) of +5.0 Volts.
3. Performance as measured on ANADIGICS test fixture (see Figure 3).

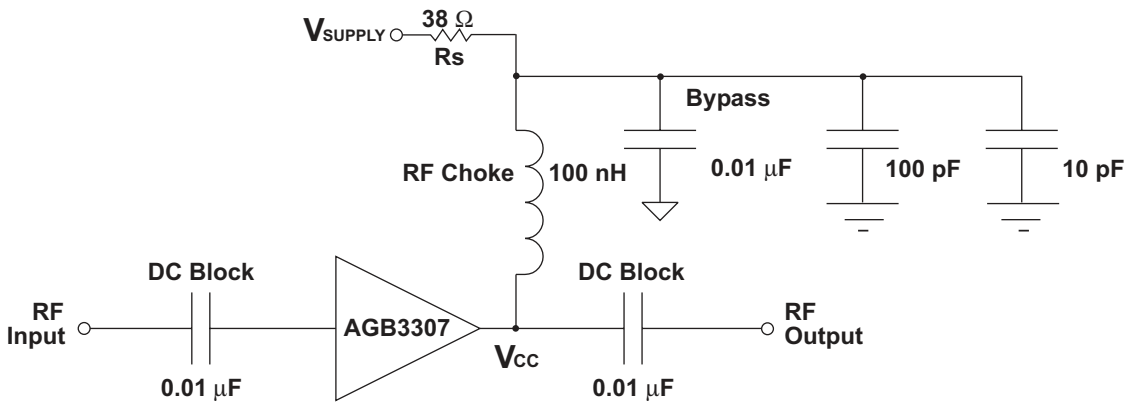

**Figure 3: Application Circuit (50Ω Terminations)**

PERFORMANCE DATA

**Figure 4: Gain vs. Frequency**  
**De-embedded 50Ω S-parameter**  
 (T<sub>A</sub> = +25 °C, V<sub>CC</sub> = +5.0 V, I<sub>CC</sub> = 80 mA)

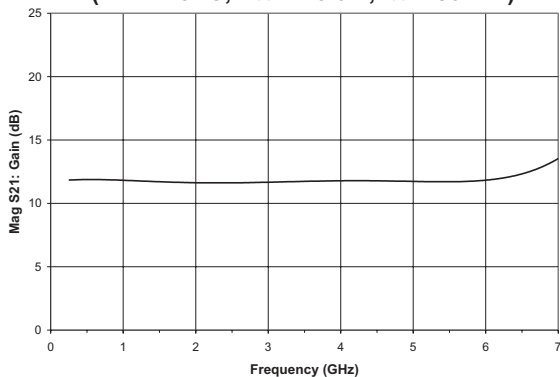

**Figure 5: Isolation vs. Frequency**  
**De-embedded 50Ω S-parameter**  
 (T<sub>A</sub> = +25 °C, V<sub>CC</sub> = +5.0 V, I<sub>CC</sub> = 80 mA)

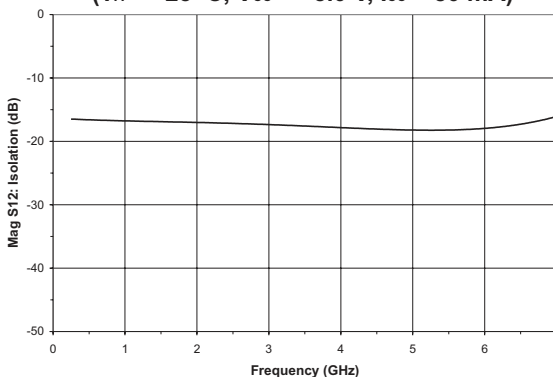

**Figure 6: Input Return Loss vs. Frequency**  
**De-embedded 50Ω S-parameter**  
 (T<sub>A</sub> = +25 °C, V<sub>CC</sub> = +5.0 V, I<sub>CC</sub> = 80 mA)

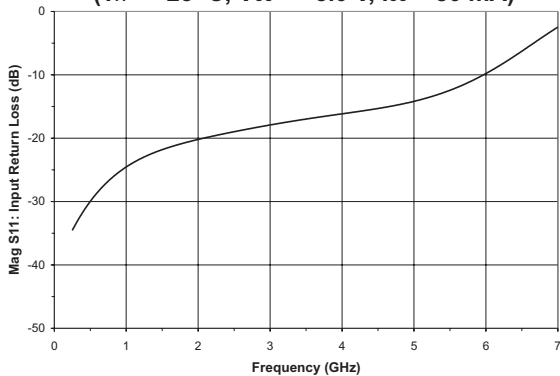

**Figure 7: Output Return Loss vs. Frequency**  
**De-embedded 50Ω S-parameter**  
 (T<sub>A</sub> = +25 °C, V<sub>CC</sub> = +5.0 V, I<sub>CC</sub> = 80 mA)

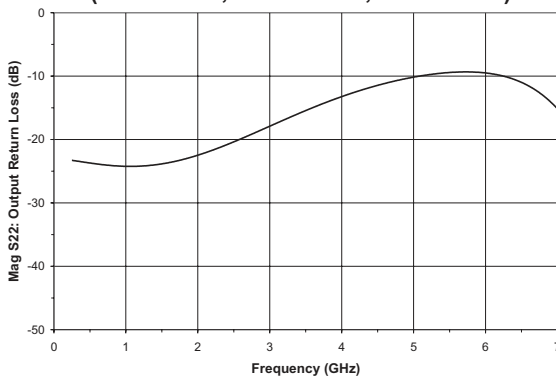

**APPLICATION INFORMATION**

The AGB3307 is optimized for a bias current of 80 mA. Using a +8 V supply, a bias resistor ( $R_s$ ) of 38  $\Omega$  will provide the appropriate bias (see Figure 3). Table 5 shows the recommended value of  $R_s$  for other supply voltages.

**Table 5: Bias Resistor Values for Various Supply Voltages**

$V_{\text{SUPPLY}}$	+8 V	+9 V	+10 V	+12 V
$R_s$	38 $\Omega$	51 $\Omega$	63 $\Omega$	88 $\Omega$

PACKAGE OUTLINE

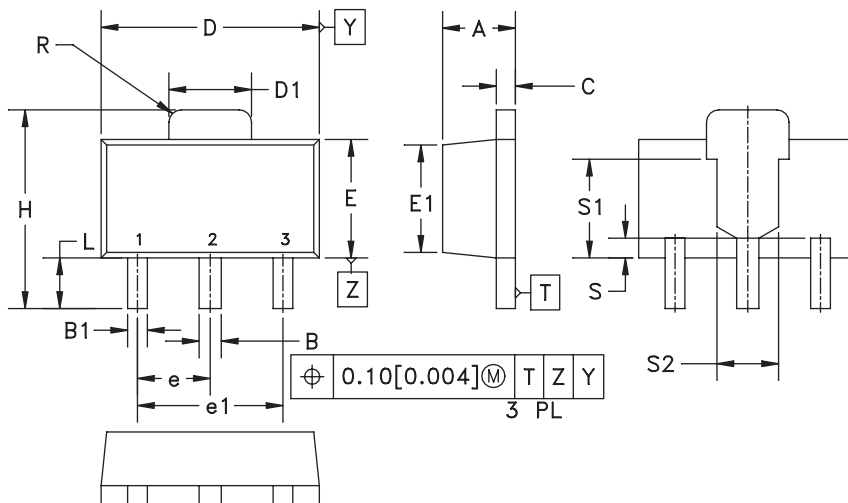

S <sub>MBO</sub>	MILLIMETERS		INCHES		NOTE
	MIN.	MAX.	MIN.	MAX.	
A	1.40	1.60	0.055	0.063	-
B	0.44	0.56	0.017	0.022	-
B1	0.36	0.48	0.014	0.019	3
C	0.35	0.44	0.014	0.017	-
D	4.40	4.60	0.173	0.181	-
D1	1.62	1.83	0.064	0.072	-
E	2.29	2.60	0.090	0.102	-
E1	2.13	2.29	0.084	0.090	4
e	1.50 BSC		0.059 BSC		-
e1	3.00 BSC		0.118 BSC		-
H	3.94	4.25	0.155	0.167	-
L	0.89	1.20	0.035	0.047	-
R	-	0.25	-	0.010	-
S	0.40 NOM.		0.016 NOM.		4
S1	2.03 NOM.		0.080 NOM.		4
S2	1.27 NOM.		0.050 NOM.		4

NOTES:

1. CONTROLLING DIMENSIONS: MILLIMETERS.
2. DIMENSIONS DO NOT INCLUDE END FLASH, MOLD FLASH OR MATERIAL PROTRUSIONS.
3. DIMENSION B1, 2 PLACES.
4. DIMENSIONS E1, S, S1 & S2 - REFERENCE ONLY.
5. REFERENCE JEDEC TO-243 (AA).

Figure 8: S24 Package Outline – SOT-89

TOP BRAND



NOTES:

1. ANADIGICS LOGO SIZE: X=0.040±0.010 Y=0.048±0.010
2. PART NUMBER: FOUR NUMERIC CHARACTERS
3. WAFER LOT NUMBER: LLLL= FOUR NUMERIC CHARACTERS  
NN= TWO ALPHABETIC CHARACTERS
4. TYPE : ELITE  
SIZE : 2-POINT  
COLOR : LASER

Figure 9: Branding Specification

**ORDERING INFORMATION**

<b>PART NUMBER</b>	<b>TEMPERATURE RANGE</b>	<b>PACKAGE DESCRIPTION</b>	<b>COMPONENT PACKAGING</b>
AGB3307S24Q1	-40 to +85°C	SOT-89 Package	1,000 piece Tape and Reel
AGB3307RS24Q1	-40 to +85°C	RoHS Compliant SOT-89 Package	1,000 piece Tape and Reel

**ANADIGICS, Inc.**

141 Mount Bethel Road  
Warren, New Jersey 07059, U.S.A.

Tel: +1 (908) 668-5000

Fax: +1 (908) 668-5132

URL: <http://www.anadigics.com>

E-mail: [Mktg@anadigics.com](mailto:Mktg@anadigics.com)

**IMPORTANT NOTICE**

ANADIGICS, Inc. reserves the right to make changes to its products or to discontinue any product at any time without notice. The product specifications contained in Advanced Product Information sheets and Preliminary Data Sheets are subject to change prior to a product's formal introduction. Information in Data Sheets have been carefully checked and are assumed to be reliable; however, ANADIGICS assumes no responsibilities for inaccuracies. ANADIGICS strongly urges customers to verify that the information they are using is current before placing orders.

**WARNING**

ANADIGICS products are not intended for use in life support appliances, devices or systems. Use of an ANADIGICS product in any such application without written consent is prohibited.