

DRV120 Single-Channel Relay, Solenoid, Valve Low-Side Driver With Current Regulation

1 Features

- Integrated MOSFET With PWM to Control Solenoid Current
 - Integrated Sense Resistor for Regulating Solenoid Current
- Fast Ramp-Up of Solenoid Current to Guarantee Activation
- Solenoid Current is Reduced in Hold Mode for Lower Power and Thermal Dissipation
- Peak Current, Keep Time at Peak Current, Hold Current, and PWM Clock Frequency Can Be Set Externally. They Can Also Be Operated at Nominal Values Without External Components.
- Internal Supply Voltage Regulation
 - Up to 28-V External Supply
- Protection
 - Thermal Shutdown
 - Undervoltage Lockout (UVLO)
 - Maximum Ramp Time
 - Optional STATUS Output
- Operating Temperature Range: -40°C to 105°C
- 8-Pin and 14-Pin TSSOP Package Options

2 Applications

- Electromechanical Drivers: Solenoids, Valves, Relays
- White Goods, Solar, Transportation

3 Description

The DRV120 device is a PWM current driver for solenoids. The device is designed to regulate the current with a well-controlled waveform to guarantee activation and to reduce power dissipation at the same time. The solenoid current is ramped up fast to ensure opening of the valve or relay. After the initial ramping, solenoid current is kept at peak value to ensure the correct operation, after which it is reduced to a lower hold level in order to avoid thermal problems and reduce power dissipation.

The peak current duration is set with an external capacitor. The current ramp peak and hold levels, as well as PWM frequency, can independently be set with external resistors. External setting resistors can also be omitted, if the default values for the corresponding parameters are suitable for the application.

The DRV120 can operate from an external 6-V to 28-V supply.

Device Information⁽¹⁾

PART NUMBER	PACKAGE	BODY SIZE (NOM)
DRV120	TSSOP (14)	5.00 mm × 4.40 mm
	TSSOP (8)	3.00 mm × 4.40 mm

(1) For all available packages, see the orderable addendum at the end of the data sheet.

I_{SOLENOID} vs Time

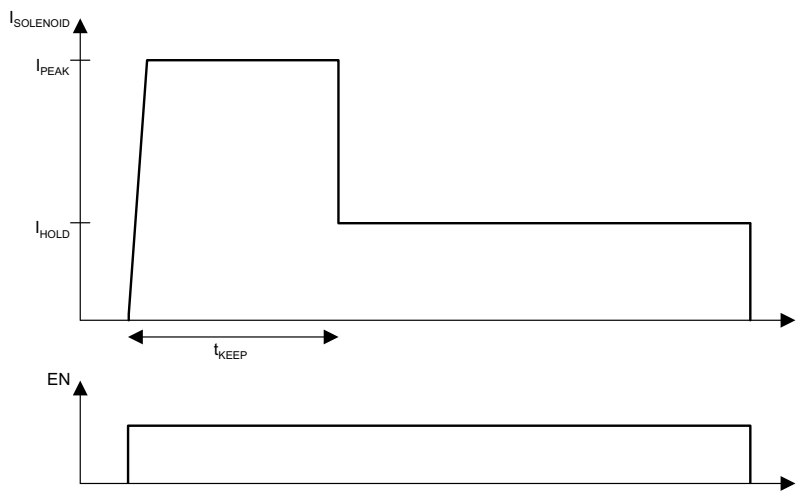

Table of Contents

1 Features	1	7.4 Device Functional Modes.....	9
2 Applications	1	8 Application and Implementation	10
3 Description	1	8.1 Application Information.....	10
4 Revision History	2	8.2 Typical Application	10
5 Pin Configuration and Functions	3	9 Power Supply Recommendations	12
6 Specifications	3	10 Layout	12
6.1 Absolute Maximum Ratings	3	10.1 Layout Guidelines	12
6.2 ESD Ratings.....	4	10.2 Layout Example	12
6.3 Recommended Operating Conditions.....	4	11 Device and Documentation Support	13
6.4 Thermal Information	4	11.1 Documentation Support	13
6.5 Electrical Characteristics.....	5	11.2 Receiving Notification of Documentation Updates	13
6.6 Typical Characteristics	6	11.3 Community Resources.....	13
7 Detailed Description	7	11.4 Trademarks	13
7.1 Overview	7	11.5 Electrostatic Discharge Caution.....	13
7.2 Functional Block Diagram	7	11.6 Glossary	13
7.3 Feature Description.....	7	12 Mechanical, Packaging, and Orderable Information	13

4 Revision History

NOTE: Page numbers for previous revisions may differ from page numbers in the current version.

Changes from Revision B (July 2015) to Revision C	Page
• Changed the title of the data sheet	1
• Changed the minimum R_{OSC} value in the f_{PWM} equation from 66.67 k Ω to 160 k Ω	9
• Changed the <i>PWM Clock Frequency Setting</i> graph.....	9
• Added the <i>Receiving Notification of Documentation Updates</i> section	13

Changes from Revision A (August 2012) to Revision B	Page
• Added <i>Pin Configuration and Functions</i> section, <i>ESD Ratings</i> table, <i>Feature Description</i> section, <i>Device Functional Modes</i> , <i>Application and Implementation</i> section, <i>Power Supply Recommendations</i> section, <i>Layout</i> section, <i>Device and Documentation Support</i> section, and <i>Mechanical, Packaging, and Orderable Information</i> section	1

5 Pin Configuration and Functions

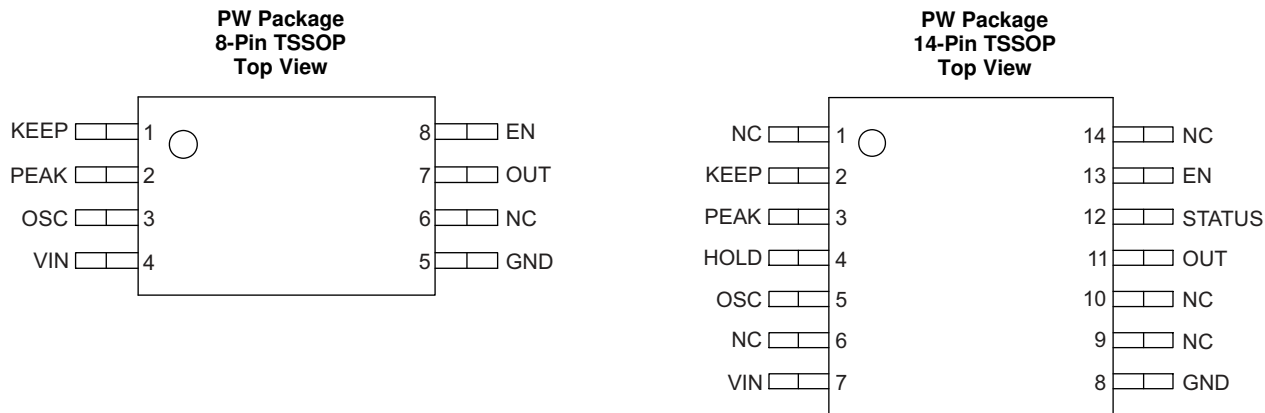

Pin Functions

NAME	PIN NO.		I/O	DESCRIPTION
	8-PIN PW ⁽¹⁾	14-PIN PW		
EN	8	13	I	Enable
GND	5	8	—	Ground
HOLD	-	4	I	Hold current set
KEEP	1		I	Keep time set
NC	6	1, 6, 9, 10, 14	—	No connect
OSC	3	5	I	PWM frequency set
OUT	7	11	O	Controlled current sink
PEAK	2	3	I	Peak current set
STATUS	-	12	O	Open-drain fault indicator
VIN	4	7	I	6-V to 28-V supply

(1) In the 8-pin package, the HOLD pin is not bonded out. For this package, the HOLD mode is configured to default (internal) settings.

6 Specifications

6.1 Absolute Maximum Ratings

See ⁽¹⁾ and ⁽²⁾

		MIN	MAX	UNIT
VIN	Input voltage	-0.3	28	V
	Voltage on EN, STATUS, PEAK, HOLD, OSC, SENSE, RAMP	-0.3	7	V
	Voltage on OUT	-0.3	28	V
T _J	Operating virtual junction temperature	-40	125	°C
T _{stg}	Storage temperature	-65	150	°C

- (1) Stresses beyond those listed under *Absolute Maximum Ratings* may cause permanent damage to the device. These are stress ratings only, and functional operation of the device at these or any other conditions beyond those indicated under *Recommended Operating Conditions* is not implied. Exposure to absolute-maximum-rated conditions for extended periods may affect device reliability.
- (2) All voltage values are with respect to network ground pin.

6.2 ESD Ratings

		VALUE	UNIT
V _(ESD)	Electrostatic discharge	±2000	V
		±500	

(1) JEDEC document JEP155 states that 500-V HBM allows safe manufacturing with a standard ESD control process.

(2) JEDEC document JEP157 states that 250-V CDM allows safe manufacturing with a standard ESD control process.

6.3 Recommended Operating Conditions

over operating free-air temperature range (unless otherwise noted)

		MIN	NOM	MAX	UNIT
I _{OUT}	Average solenoid DC current			125	mA
V _{IN}	Supply voltage	6	12	26	V
C _{IN}	Input capacitor	1	4.7		μF
L	Solenoid inductance		1		H
T _A	Operating ambient temperature	–40		105	°C

6.4 Thermal Information

THERMAL METRIC ⁽¹⁾		DRV120		UNIT
		PW [TSSOP]		
		8 PINS	14 PINS	
R _{θJA}	Junction-to-ambient thermal resistance	183.8	122.6	°C/W
R _{θJC(top)}	Junction-to-case (top) thermal resistance	69.2	51.2	°C/W
R _{θJB}	Junction-to-board thermal resistance	112.6	64.3	°C/W
ψ _{JT}	Junction-to-top characterization parameter	10.4	6.5	°C/W
ψ _{JB}	Junction-to-board characterization parameter	110.9	63.7	°C/W
R _{θJC(bot)}	Junction-to-case (bottom) thermal resistance	N/A	N/A	°C/W

(1) For more information about traditional and new thermal metrics, see the [Semiconductor and IC Package Thermal Metrics](#) application report.

6.5 Electrical Characteristics

 $V_{IN} = 14\text{ V}$, $T_A = -40^\circ\text{C}$ to 105°C , over operating free-air temperature range (unless otherwise noted)

PARAMETER		TEST CONDITIONS	MIN	TYP	MAX	UNIT
SUPPLY						
I_Q	Standby current	EN = 0, $V_{IN} = 14\text{ V}$		100	150	μA
	Quiescent current	EN = 1, $V_{IN} = 14\text{ V}$		300	400	
CURRENT DRIVER						
R_{OUT}	OUT to GND resistance	$I_{OUT} = 200\text{ mA}$		1.7	2.5	Ω
f_{PWM}	PWM frequency	OSC = GND	15	20	25	kHz
D_{MAX}	Maximum PWM duty cycle			100		%
D_{MIN}	Minimum PWM duty cycle			9		%
t_D	Start-up delay	Delay between EN going high until driver enabled ⁽¹⁾ , $f_{PWM} = 20\text{ kHz}$		25	50	μs
CURRENT CONTROLLER, INTERNAL SETTINGS						
I_{PEAK}	Peak current	PEAK = GND	160	200	240	mA
I_{HOLD}	Hold current	HOLD = GND	40	50	60	mA
CURRENT CONTROLLER, EXTERNAL SETTINGS						
$t_{KEEP}^{(2)}$	Externally set keep time at peak current	$C_{KEEP} = 1\ \mu\text{F}$		75		ms
I_{PEAK}	Externally set peak current	$R_{PEAK} = 50\text{ k}\Omega$		250		mA
		$R_{PEAK} = 200\text{ k}\Omega$		83		
I_{HOLD}	Externally set hold current	$R_{HOLD} = 50\text{ k}\Omega$		100		mA
		$R_{HOLD} = 200\text{ k}\Omega$		33		
f_{PWM}	Externally set PWM frequency	$R_{OSC} = 50\text{ k}\Omega$		60		kHz
		$R_{OSC} = 200\text{ k}\Omega$		20		
LOGIC INPUT LEVELS (EN)						
V_{IL}	Input low level				1.3	V
V_{IH}	Input high level		1.65			V
R_{EN}	Input pullup resistance		350	500		k Ω
LOGIC OUTPUT LEVELS (STATUS)						
V_{OL}	Output low level	Pulldown activated, $I_{STATUS} = 2\text{ mA}$			0.3	V
I_{IL}	Output leakage current	Pulldown deactivated, $V(\text{STATUS}) = 5\text{ V}$			1	μA
UNDERVOLTAGE LOCKOUT						
V_{UVLO}	Undervoltage lockout threshold			4.6		V
THERMAL SHUTDOWN						
T_{TSD}	Junction temperature shutdown threshold			160		$^\circ\text{C}$
T_{TSU}	Junction temperature start-up threshold			140		$^\circ\text{C}$

(1) Logic HIGH between 4 V and 7 V. Note: absolute maximum voltage rating is 7 V.

(2) Either internal or external t_{KEEP} time setting is selected to be activated during manufacturing of production version of DRV120.

6.6 Typical Characteristics

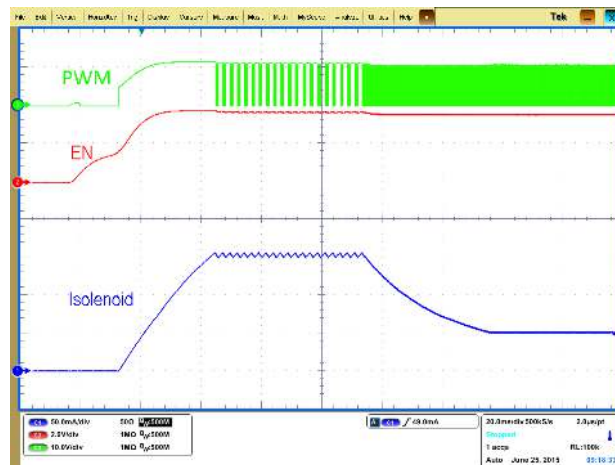

Figure 1. Solenoid Current, EN, and PWM vs Time

7 Detailed Description

7.1 Overview

The DRV120 device provides a PWM current converter for use with solenoids. The device provides a quick ramp to a high peak current value in order to ensure opening of the valve or relay. The peak current is held for a programmable time and then released to a lower value to maintain the open state of the valve or relay while reducing the total current consumption. Peak current duration, peak current amount, hold current amount (in the 14-pin package), and PWM frequency can all be controlled by external components or used at default levels by omitting these components (except peak current duration). Enable and disable of the switch is controlled by the EN pin which has an internal pullup to V_{IN} . The DRV120 also features a wide V_{IN} range from 6 V to 28 V. Finally, the 14-pin package features an open-drain pulldown path on the STATUS pin which is enabled as long as undervoltage lockout or thermal shutdown has not triggered.

7.2 Functional Block Diagram

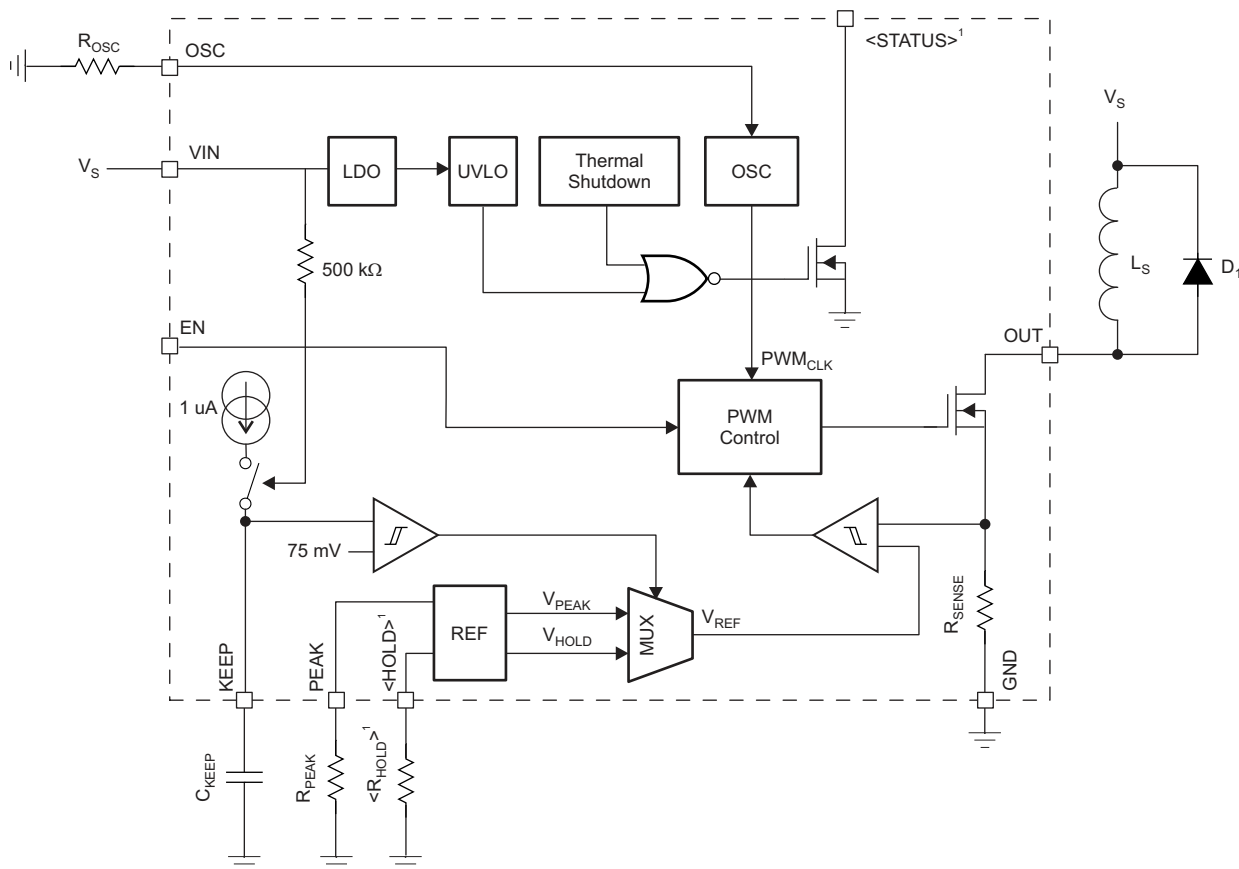

¹Available only in the 14-pin package

7.3 Feature Description

The DRV120 controls the current through the solenoid as shown in Figure 2. Activation starts when EN pin voltage is pulled high either by an external driver or internal pullup. In the beginning of activation, DRV120 allows the load current to ramp up to the peak value I_{PEAK} and it regulates it at the peak value for the time, t_{KEEP} , before reducing it to I_{HOLD} . The load current is regulated at the hold value as long as the EN pin is kept high. The initial current ramp-up time depends on the inductance and resistance of the solenoid. Once EN pin is driven to GND, DRV120 allows the solenoid current to decay to zero.

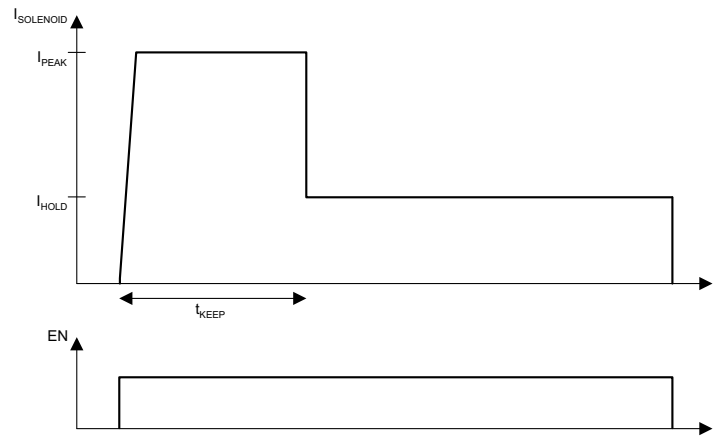
Feature Description (continued)

Figure 2. Typical Current Waveform Through the Solenoid

t_{KEEP} is set externally by connecting a capacitor to the KEEP pin. A constant current is sourced from the KEEP pin that is driven into an external capacitor resulting in a linear voltage ramp. When the KEEP pin voltage reaches 75 mV, the current regulation reference voltage, V_{REF} , is switched from V_{PEAK} to V_{HOLD} . Dependency of t_{KEEP} from the external capacitor size can be calculated with [Equation 1](#).

$$t_{KEEP} [s] = C_{KEEP} [F] \cdot 75 \cdot 10^3 \left[\frac{s}{F} \right] \quad (1)$$

The current control loop regulates, cycle-by-cycle, the solenoid current by using an internal current-sensing resistor and MOSFET switch. During the ON-cycle, current flows from OUT pin to GND pin through the internal switch as long as voltage across the current-sensing resistor is less than V_{REF} . As soon as the current sensing voltage is above V_{REF} , the internal switch is immediately turned off until the next ON-cycle is triggered by the internal PWM clock signal. In the beginning of each ON-cycle, the internal switch is turned on and stays on for at least the time determined by the minimum PWM signal duty cycle, D_{MIN} .

I_{PEAK} and I_{HOLD} depend on fixed resistance values R_{PEAK} and R_{HOLD} approximately as shown in [Figure 3](#). If the PEAK pin is connected to ground or if R_{PEAK} or R_{HOLD} is below 33.33 k Ω (typical value), then I_{PEAK} is at its default value (internal setting) of 200 mA for I_{PEAK} and 50 mA for I_{HOLD} . The I_{PEAK} value can alternatively be set by connecting an external resistor to ground from the PEAK pin. For example, if a 50-k Ω ($= R_{PEAK}$) resistor is connected between PEAK and GND, then the externally set I_{PEAK} level will be 250 mA. If $R_{PEAK} = 200$ k Ω is, then the externally set I_{PEAK} level will be 83 mA. In the 8-pin package, I_{HOLD} is set to 50 mA by default. In the 14-pin package, external settings of I_{HOLD} works in the same way as I_{PEAK} . External settings for I_{PEAK} and I_{HOLD} are independent of each other. Approximate I_{PEAK} and I_{HOLD} values can be calculated by using [Equation 2](#) and [Equation 3](#).

$$I_{PEAK} = \frac{250mA}{R_{PEAK}} \cdot 66.67k\Omega; 66.67k\Omega < R_{PEAK} < 550k\Omega \quad (2)$$

$$I_{HOLD} = \frac{100mA}{R_{HOLD}} \cdot 66.67k\Omega; 66.67k\Omega < R_{HOLD} < 250k\Omega \quad (3)$$

Feature Description (continued)

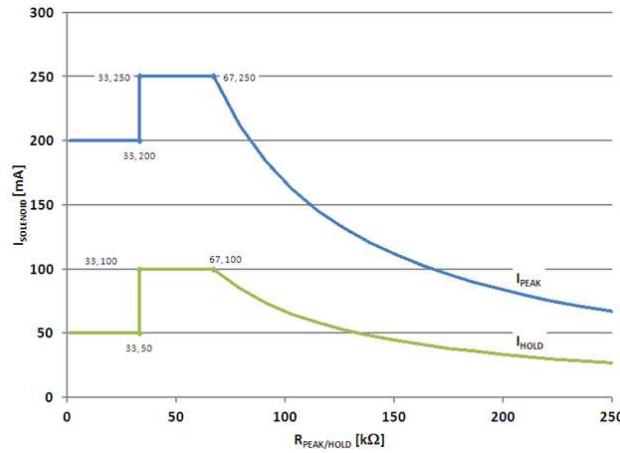

Figure 3. PEAK and HOLD Mode Current Settings

Frequency of the internal PWM clock signal, PWM_{CLK}, that triggers each ON-cycle can be adjusted by external resistor, R_{OSC}, connected between OSC and GND. Frequency as a function of resistor value is shown in Figure 4. Default frequency is used when OSC is connected to GND directly. Use Equation 4 to calculate the PWM frequency as a function of the external fixed adjustment resistor value (greater than 160 kΩ).

$$f_{\text{PWM}} = \frac{60 \text{ kHz}}{R_{\text{OSC}}} \times 66.67 \text{ k}\Omega; 160 \text{ k}\Omega < R_{\text{OSC}} < 2 \text{ M}\Omega \tag{4}$$

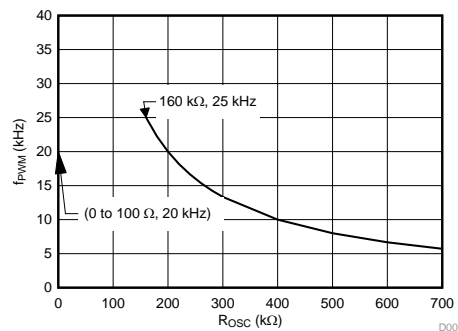

Figure 4. PWM Clock Frequency Setting

Open-drain STATUS output is deactivated if either undervoltage lockout or thermal shutdown blocks have triggered.

7.4 Device Functional Modes

The DRV120 transitions through three different states. The first is the OFF state, where the EN pin is low and the PWM output is off. The second is the PEAK state, which begins when the EN pin is pulled high by an external controller or internal pullup, and ends once t_{KEEP} has been reached. During this state, the PWM operates in order to reach the I_{PEAK} set by the R_{PEAK}. Finally, once t_{KEEP} has been reached, the PWM continues to operate, but at the I_{HOLD} level. This continues until the EN pin is forced low again and the PWM turns off.

8 Application and Implementation

NOTE

Information in the following applications sections is not part of the TI component specification, and TI does not warrant its accuracy or completeness. TI's customers are responsible for determining suitability of components for their purposes. Customers should validate and test their design implementation to confirm system functionality.

8.1 Application Information

The DRV120 device is designed to operate a solenoid valve or relay. A typical DC input design will be outlined in [Typical Application](#). Approximate resistor and capacitor values for the peak current, hold current, and keep time will be derived for a sample application.

8.2 Typical Application

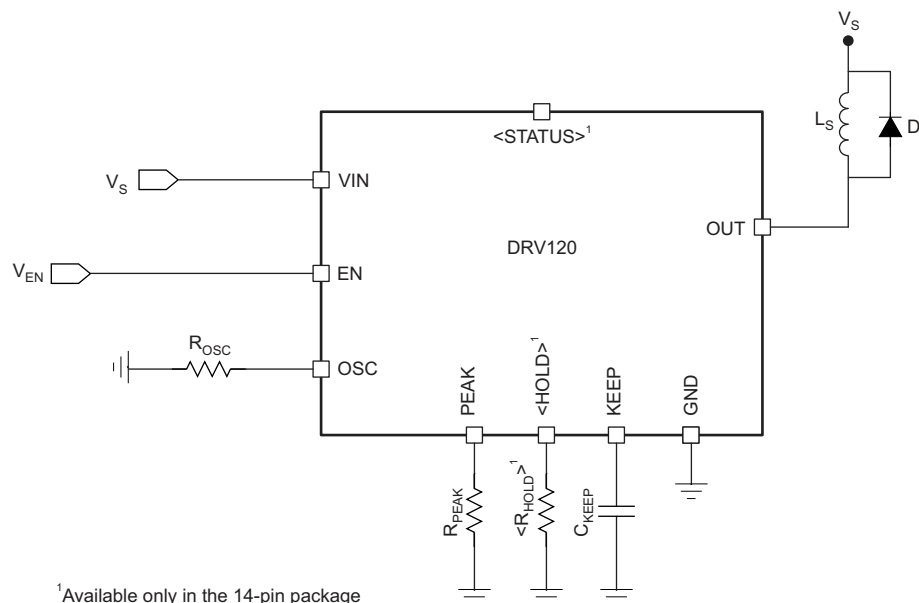

Figure 5. Default Configuration

8.2.1 Design Requirements

The key elements to identify here are the system input voltage, peak current, hold current, and peak keep time values required for the solenoid or relay being used. With these values, approximate R_S , R_{PEAK} , R_{HOLD} (for 14-pin package), and C_{KEEP} values can be determined and the proper FET and diode can be identified. R_{OSC} can be varied in order to tune the circuit to the chosen solenoid or relay.

8.2.2 Detailed Design Procedure

First, with the known peak current, hold current, and peak keep time values known, the R_{PEAK} , R_{HOLD} (for 14-pin package), and C_{KEEP} values can be determined. Calculation will proceed based on example values shown in [Table 1](#).

Table 1. Sample Application Values

VARIABLE	VALUE
Peak current	150 mA
Hold current	50 mA
Keep time	100 ms

R_{PEAK} and R_{HOLD} (if applicable) can be determined using Equation 2 and Equation 3. For the sample values, R_{PEAK} is set to 111 k Ω and R_{HOLD} can be shorted to GND. TI recommends that a 0- Ω resistor is used for prototyping in case changes to this value are desired.

Next, C_{KEEP} can be set based on Equation 1, 1.33 μ F for the sample values. R_{OSC} can initially be shorted to GND, but again a 0- Ω resistor is recommended for prototyping. Additionally, a filter on the SENSE line may be added if it will be in a high-noise environment and is recommended for prototyping. Typical values for this are 1 k Ω and 100 pF.

Finally, a current recirculation diode must be chosen based on the current values defined in Table 1. The current recirculation diode should be a fast recovery diode.

8.2.3 Application Curves

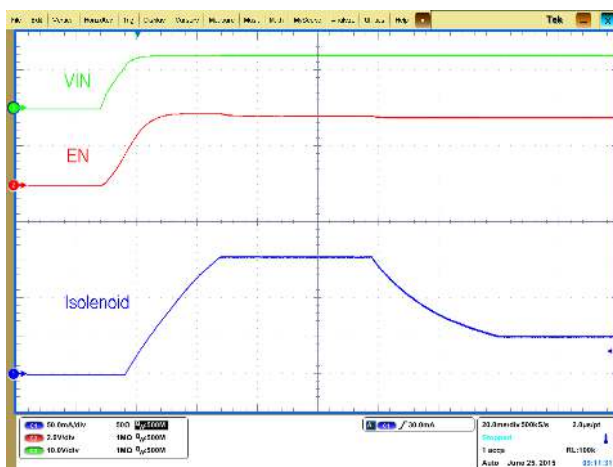

$L_{ind} = 1 \text{ H}$

$R_{ind} = 50 \text{ } \Omega$

Figure 6. $I_{SOLENOID}$, EN, and V_{IN} vs Time

9 Power Supply Recommendations

The input supply range must be at least 6 V and should be below 26 V. An input capacitor of 4.7 μF (typical) is required as well. Current requirements will be set by the required current from the solenoid.

10 Layout

10.1 Layout Guidelines

The trace for the solenoid or relay current should be wide in order to prevent any unexpected voltage drop. Diode placement should not be far from the inductor and both should be placed close to the output.

10.2 Layout Example

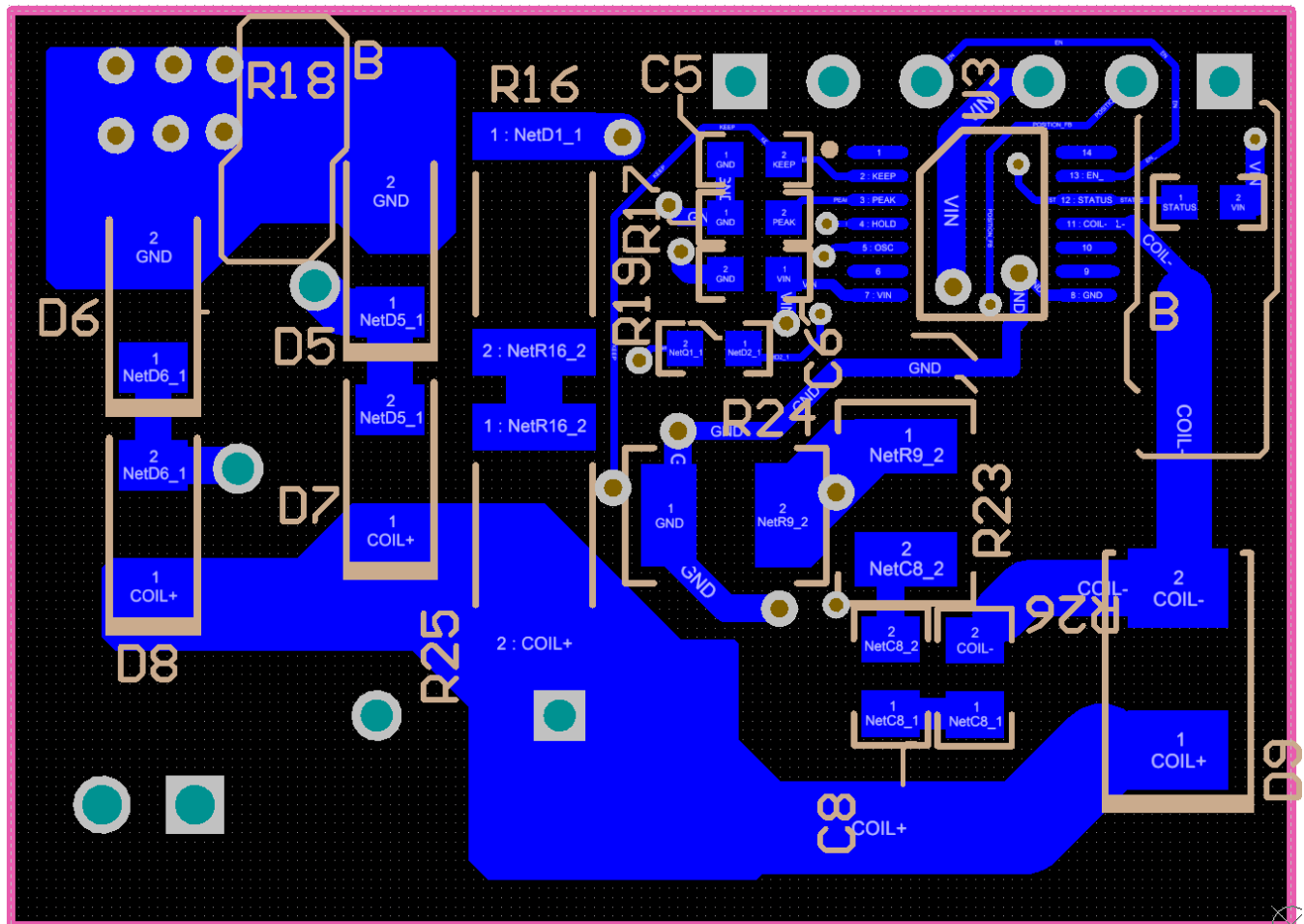

Figure 7. Layout Schematic

11 Device and Documentation Support

11.1 Documentation Support

11.1.1 Related Documentation

For related documentation, see the following:

[Current Controlled Driver for 230V AC Solenoids Reference Design DRV110 and DRV120 Evaluation Modules \(EVM\)](#)

11.2 Receiving Notification of Documentation Updates

To receive notification of documentation updates, navigate to the device product folder on ti.com. In the upper right corner, click on *Alert me* to register and receive a weekly digest of any product information that has changed. For change details, review the revision history included in any revised document.

11.3 Community Resources

The following links connect to TI community resources. Linked contents are provided "AS IS" by the respective contributors. They do not constitute TI specifications and do not necessarily reflect TI's views; see TI's [Terms of Use](#).

TI E2E™ Online Community *TI's Engineer-to-Engineer (E2E) Community*. Created to foster collaboration among engineers. At e2e.ti.com, you can ask questions, share knowledge, explore ideas and help solve problems with fellow engineers.

Design Support *TI's Design Support* Quickly find helpful E2E forums along with design support tools and contact information for technical support.

11.4 Trademarks

E2E is a trademark of Texas Instruments.
All other trademarks are the property of their respective owners.

11.5 Electrostatic Discharge Caution



This integrated circuit can be damaged by ESD. Texas Instruments recommends that all integrated circuits be handled with appropriate precautions. Failure to observe proper handling and installation procedures can cause damage.

ESD damage can range from subtle performance degradation to complete device failure. Precision integrated circuits may be more susceptible to damage because very small parametric changes could cause the device not to meet its published specifications.

11.6 Glossary

[SLYZ022](#) — *TI Glossary*.

This glossary lists and explains terms, acronyms, and definitions.

12 Mechanical, Packaging, and Orderable Information

The following pages include mechanical, packaging, and orderable information. This information is the most current data available for the designated devices. This data is subject to change without notice and revision of this document. For browser-based versions of this data sheet, refer to the left-hand navigation.

PACKAGING INFORMATION

Orderable Device	Status (1)	Package Type	Package Drawing	Pins	Package Qty	Eco Plan (2)	Lead finish/ Ball material (6)	MSL Peak Temp (3)	Op Temp (°C)	Device Marking (4/5)	Samples
DRV120APWR	ACTIVE	TSSOP	PW	14	2000	RoHS & Green	NIPDAU	Level-2-260C-1 YEAR	-40 to 105	120A	Samples
DRV120PWR	ACTIVE	TSSOP	PW	8	2000	RoHS & Green	NIPDAU	Level-2-260C-1 YEAR	-40 to 105	120	Samples

(1) The marketing status values are defined as follows:

ACTIVE: Product device recommended for new designs.

LIFEBUY: TI has announced that the device will be discontinued, and a lifetime-buy period is in effect.

NRND: Not recommended for new designs. Device is in production to support existing customers, but TI does not recommend using this part in a new design.

PREVIEW: Device has been announced but is not in production. Samples may or may not be available.

OBSOLETE: TI has discontinued the production of the device.

(2) **RoHS:** TI defines "RoHS" to mean semiconductor products that are compliant with the current EU RoHS requirements for all 10 RoHS substances, including the requirement that RoHS substance do not exceed 0.1% by weight in homogeneous materials. Where designed to be soldered at high temperatures, "RoHS" products are suitable for use in specified lead-free processes. TI may reference these types of products as "Pb-Free".

RoHS Exempt: TI defines "RoHS Exempt" to mean products that contain lead but are compliant with EU RoHS pursuant to a specific EU RoHS exemption.

Green: TI defines "Green" to mean the content of Chlorine (Cl) and Bromine (Br) based flame retardants meet JS709B low halogen requirements of <=1000ppm threshold. Antimony trioxide based flame retardants must also meet the <=1000ppm threshold requirement.

(3) MSL, Peak Temp. - The Moisture Sensitivity Level rating according to the JEDEC industry standard classifications, and peak solder temperature.

(4) There may be additional marking, which relates to the logo, the lot trace code information, or the environmental category on the device.

(5) Multiple Device Markings will be inside parentheses. Only one Device Marking contained in parentheses and separated by a "~" will appear on a device. If a line is indented then it is a continuation of the previous line and the two combined represent the entire Device Marking for that device.

(6) Lead finish/Ball material - Orderable Devices may have multiple material finish options. Finish options are separated by a vertical ruled line. Lead finish/Ball material values may wrap to two lines if the finish value exceeds the maximum column width.

Important Information and Disclaimer:The information provided on this page represents TI's knowledge and belief as of the date that it is provided. TI bases its knowledge and belief on information provided by third parties, and makes no representation or warranty as to the accuracy of such information. Efforts are underway to better integrate information from third parties. TI has taken and continues to take reasonable steps to provide representative and accurate information but may not have conducted destructive testing or chemical analysis on incoming materials and chemicals. TI and TI suppliers consider certain information to be proprietary, and thus CAS numbers and other limited information may not be available for release.

In no event shall TI's liability arising out of such information exceed the total purchase price of the TI part(s) at issue in this document sold by TI to Customer on an annual basis.

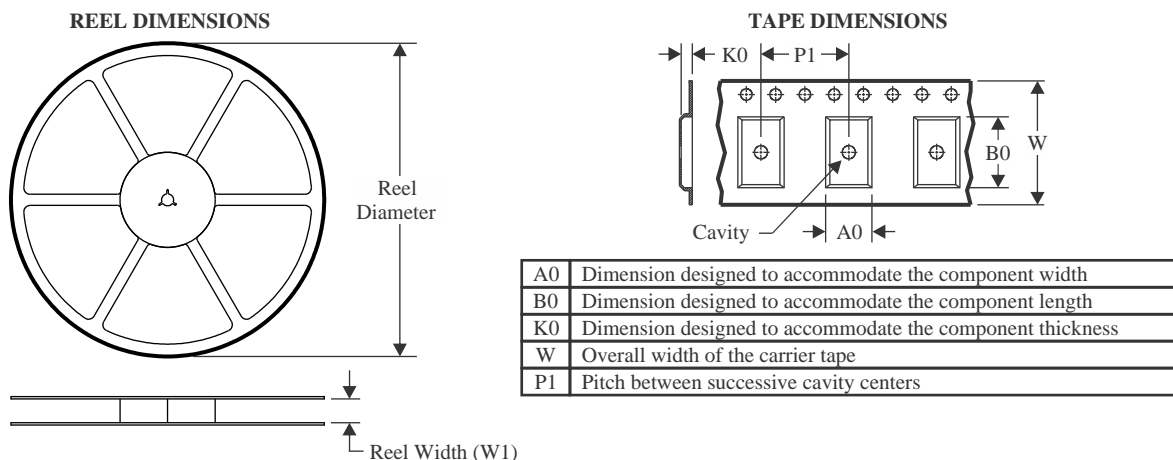
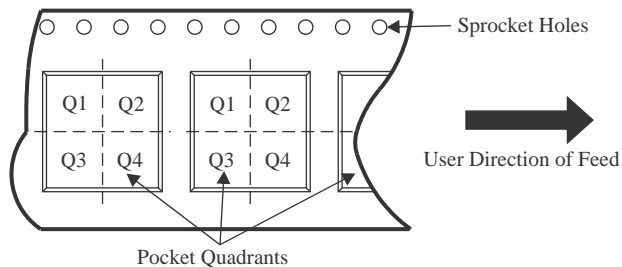
TAPE AND REEL INFORMATION

QUADRANT ASSIGNMENTS FOR PIN 1 ORIENTATION IN TAPE

*All dimensions are nominal

Device	Package Type	Package Drawing	Pins	SPQ	Reel Diameter (mm)	Reel Width W1 (mm)	A0 (mm)	B0 (mm)	K0 (mm)	P1 (mm)	W (mm)	Pin1 Quadrant
DRV120APWR	TSSOP	PW	14	2000	330.0	12.4	6.9	5.6	1.6	8.0	12.0	Q1
DRV120PWR	TSSOP	PW	8	2000	330.0	12.4	7.0	3.6	1.6	8.0	12.0	Q1

TAPE AND REEL BOX DIMENSIONS

*All dimensions are nominal

Device	Package Type	Package Drawing	Pins	SPQ	Length (mm)	Width (mm)	Height (mm)
DRV120APWR	TSSOP	PW	14	2000	356.0	356.0	35.0
DRV120PWR	TSSOP	PW	8	2000	356.0	356.0	35.0

PW (R-PDSO-G14)

PLASTIC SMALL OUTLINE

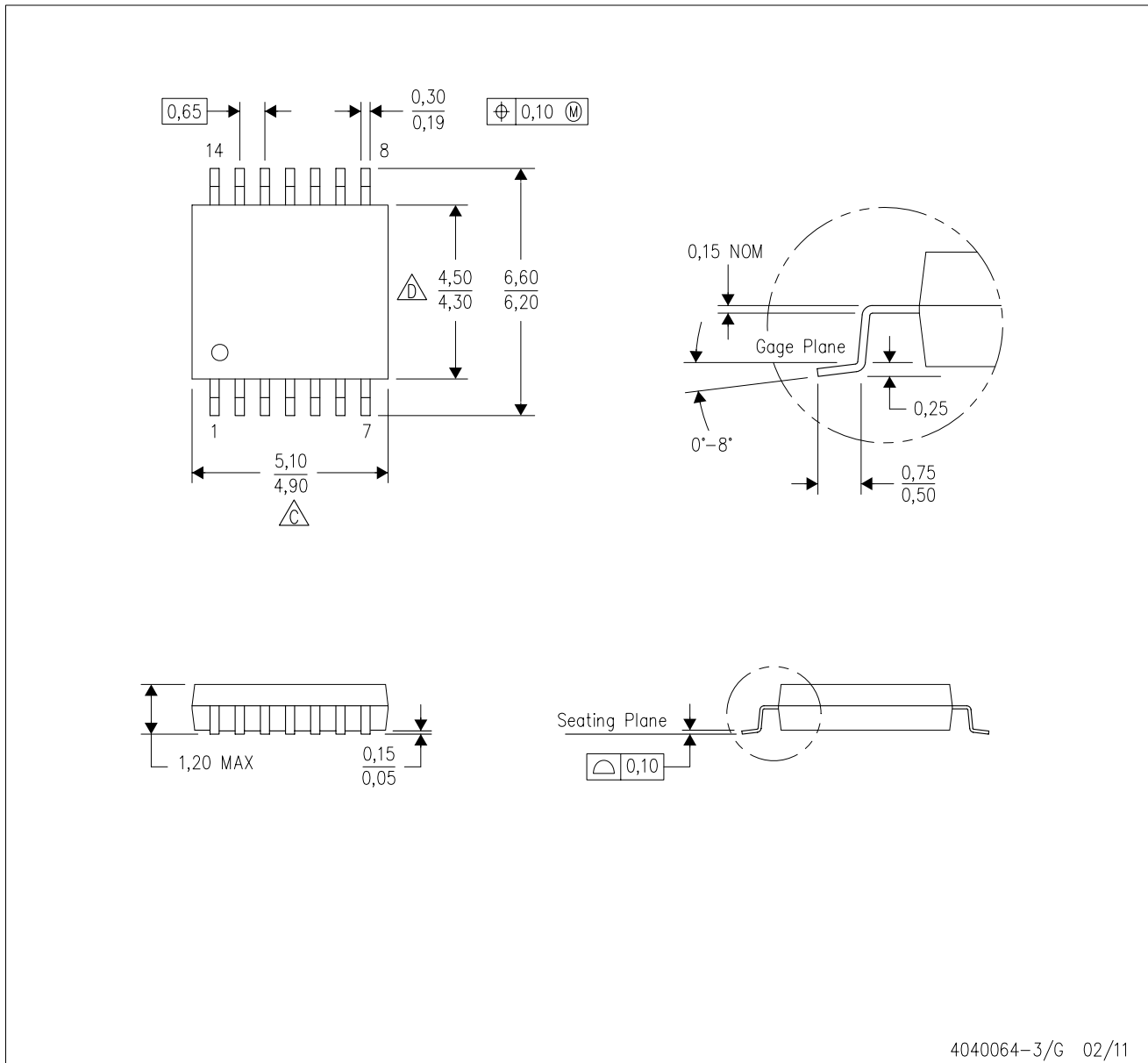

- NOTES:
- A. All linear dimensions are in millimeters. Dimensioning and tolerancing per ASME Y14.5M-1994.
 - B. This drawing is subject to change without notice.
 - C. Body length does not include mold flash, protrusions, or gate burrs. Mold flash, protrusions, or gate burrs shall not exceed 0,15 each side.
 - D. Body width does not include interlead flash. Interlead flash shall not exceed 0,25 each side.
 - E. Falls within JEDEC MO-153

PW (R-PDSO-G14)

PLASTIC SMALL OUTLINE

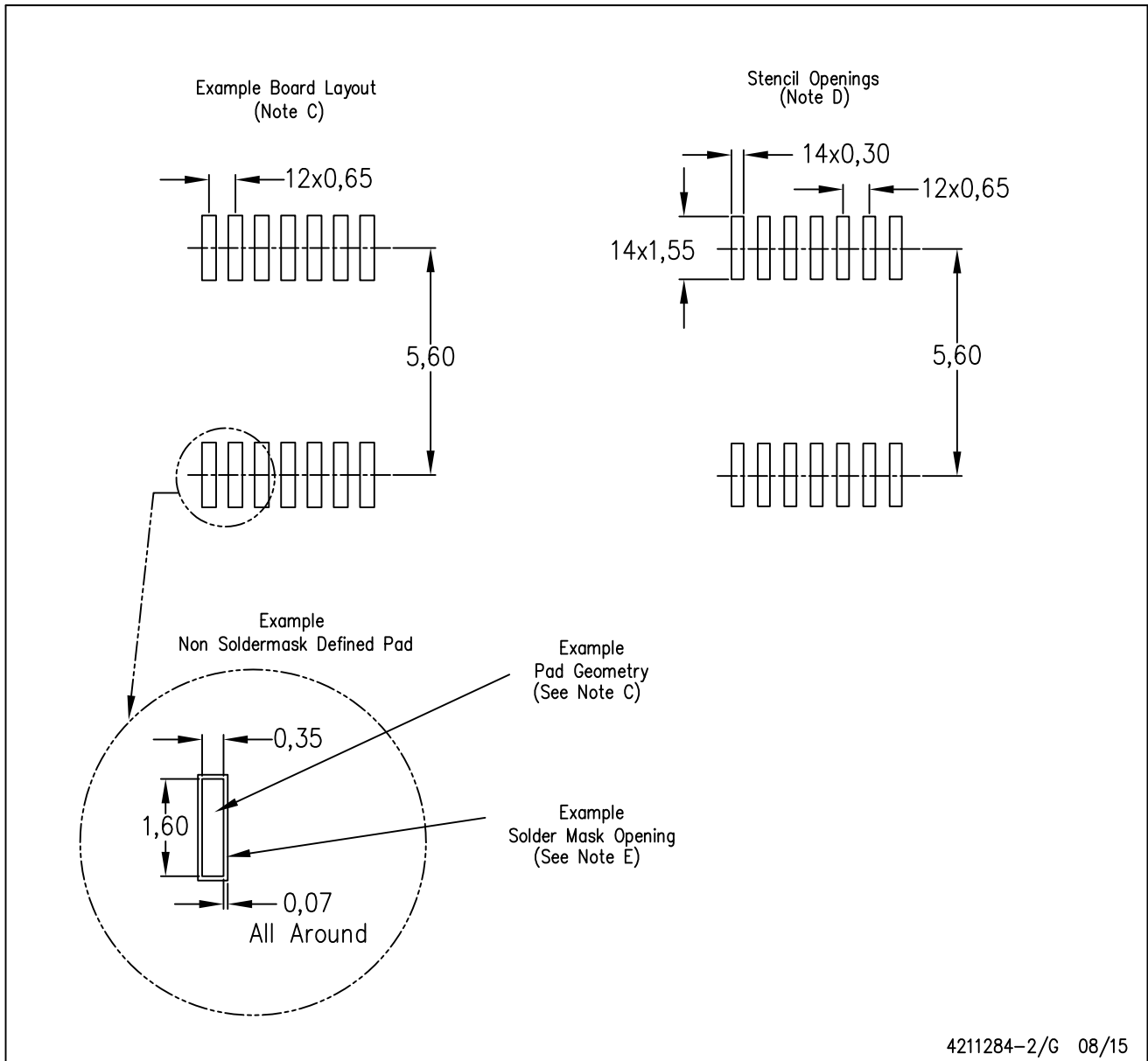

- NOTES:
- All linear dimensions are in millimeters.
 - This drawing is subject to change without notice.
 - Publication IPC-7351 is recommended for alternate designs.
 - Laser cutting apertures with trapezoidal walls and also rounding corners will offer better paste release. Customers should contact their board assembly site for stencil design recommendations. Refer to IPC-7525 for other stencil recommendations.
 - Customers should contact their board fabrication site for solder mask tolerances between and around signal pads.

PW0008A



PACKAGE OUTLINE

TSSOP - 1.2 mm max height

SMALL OUTLINE PACKAGE

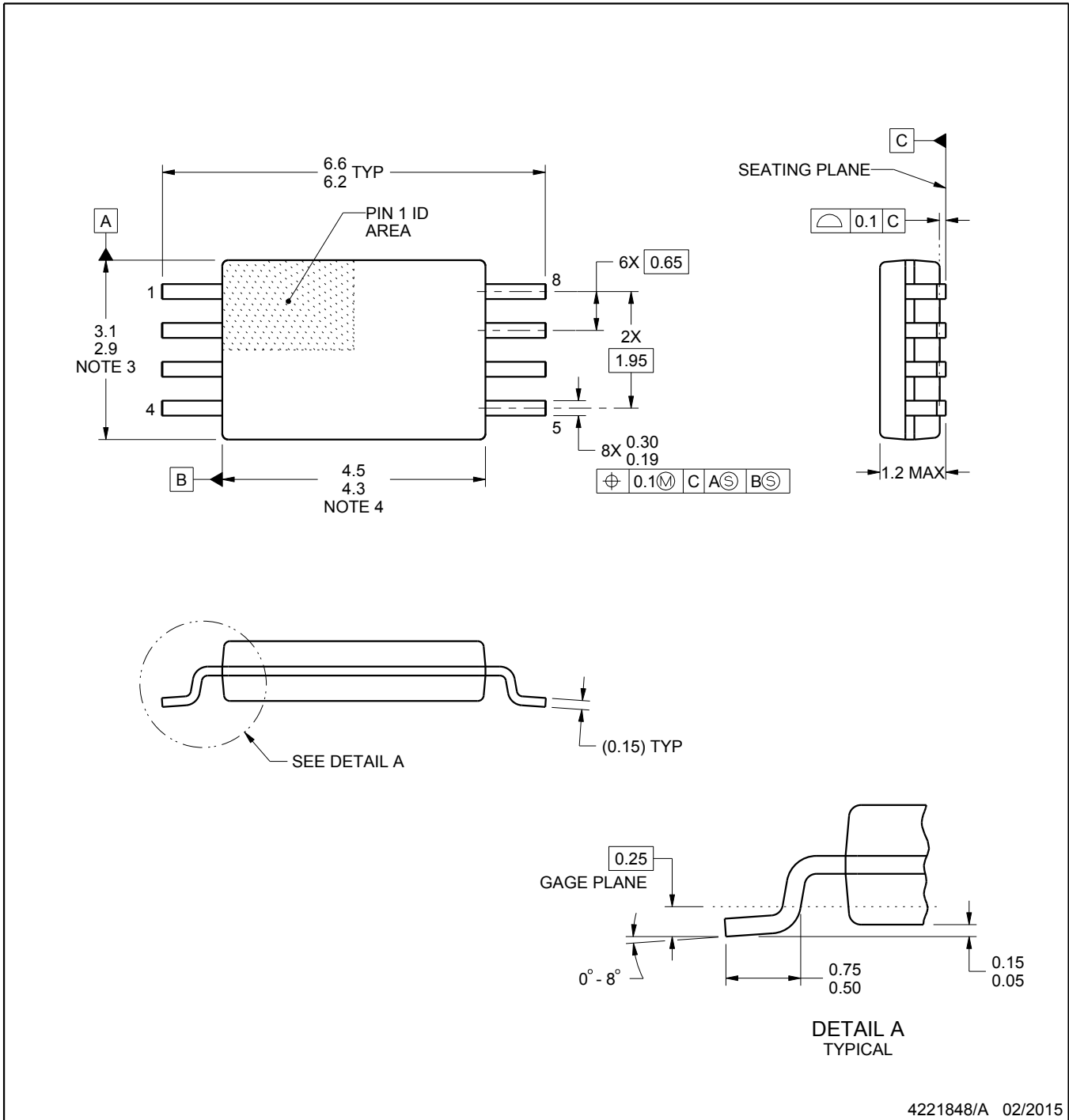

4221848/A 02/2015

NOTES:

- All linear dimensions are in millimeters. Any dimensions in parenthesis are for reference only. Dimensioning and tolerancing per ASME Y14.5M.
- This drawing is subject to change without notice.
- This dimension does not include mold flash, protrusions, or gate burrs. Mold flash, protrusions, or gate burrs shall not exceed 0.15 mm per side.
- This dimension does not include interlead flash. Interlead flash shall not exceed 0.25 mm per side.
- Reference JEDEC registration MO-153, variation AA.

EXAMPLE BOARD LAYOUT

PW0008A

TSSOP - 1.2 mm max height

SMALL OUTLINE PACKAGE

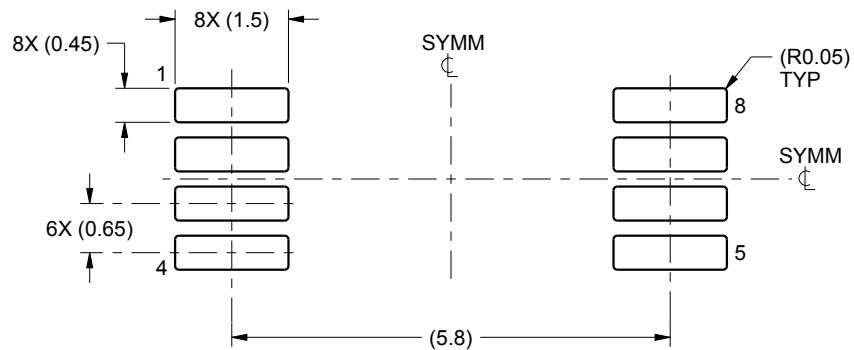

LAND PATTERN EXAMPLE
SCALE:10X

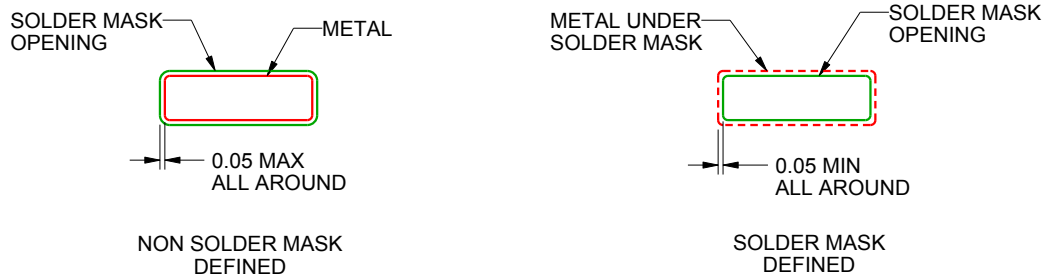

SOLDER MASK DETAILS
NOT TO SCALE

4221848/A 02/2015

NOTES: (continued)

- 6. Publication IPC-7351 may have alternate designs.
- 7. Solder mask tolerances between and around signal pads can vary based on board fabrication site.

EXAMPLE STENCIL DESIGN

PW0008A

TSSOP - 1.2 mm max height

SMALL OUTLINE PACKAGE

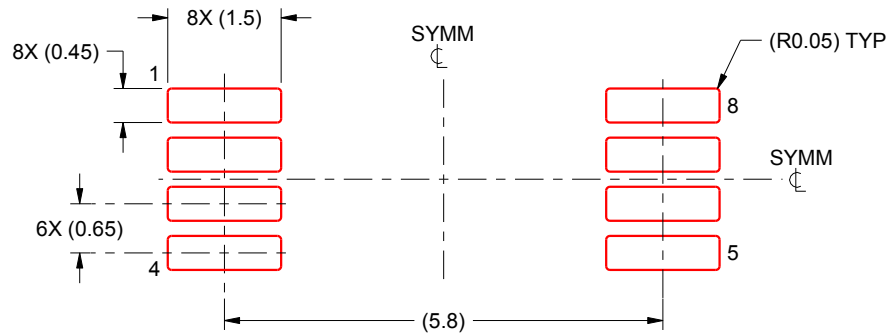

SOLDER PASTE EXAMPLE
BASED ON 0.125 mm THICK STENCIL
SCALE:10X

4221848/A 02/2015

NOTES: (continued)

8. Laser cutting apertures with trapezoidal walls and rounded corners may offer better paste release. IPC-7525 may have alternate design recommendations.
9. Board assembly site may have different recommendations for stencil design.

IMPORTANT NOTICE AND DISCLAIMER

TI PROVIDES TECHNICAL AND RELIABILITY DATA (INCLUDING DATA SHEETS), DESIGN RESOURCES (INCLUDING REFERENCE DESIGNS), APPLICATION OR OTHER DESIGN ADVICE, WEB TOOLS, SAFETY INFORMATION, AND OTHER RESOURCES "AS IS" AND WITH ALL FAULTS, AND DISCLAIMS ALL WARRANTIES, EXPRESS AND IMPLIED, INCLUDING WITHOUT LIMITATION ANY IMPLIED WARRANTIES OF MERCHANTABILITY, FITNESS FOR A PARTICULAR PURPOSE OR NON-INFRINGEMENT OF THIRD PARTY INTELLECTUAL PROPERTY RIGHTS.

These resources are intended for skilled developers designing with TI products. You are solely responsible for (1) selecting the appropriate TI products for your application, (2) designing, validating and testing your application, and (3) ensuring your application meets applicable standards, and any other safety, security, regulatory or other requirements.

These resources are subject to change without notice. TI grants you permission to use these resources only for development of an application that uses the TI products described in the resource. Other reproduction and display of these resources is prohibited. No license is granted to any other TI intellectual property right or to any third party intellectual property right. TI disclaims responsibility for, and you will fully indemnify TI and its representatives against, any claims, damages, costs, losses, and liabilities arising out of your use of these resources.

TI's products are provided subject to [TI's Terms of Sale](#) or other applicable terms available either on ti.com or provided in conjunction with such TI products. TI's provision of these resources does not expand or otherwise alter TI's applicable warranties or warranty disclaimers for TI products.

TI objects to and rejects any additional or different terms you may have proposed.

Mailing Address: Texas Instruments, Post Office Box 655303, Dallas, Texas 75265
Copyright © 2022, Texas Instruments Incorporated