

PVL SERIES PILOT INDICATOR

ANTI-VANDAL SWITCHES
DETECTOR SWITCHES
DIP SWITCHES
KEYLOCK SWITCHES
NAVIGATION SWITCHES
PUSHBUTTON SWITCHES
ROCKER SWITCHES
ROTARY SWITCHES
SLIDE SWITCHES
SNAP ACTION SWITCHES
TACTILE SWITCHES
TOGGLE SWITCHES
CAP OPTIONS



APPLICATIONS / MARKETS



Audio / Visual



Security Devices



Industrial Controls



Kiosks



Electrical Housewares



Medical Equipment

RoHS

SPECIFICATIONS

Contact Arrangement: Lamp indicator
Operating/Storage Temperature: -25°C to 55°C
Lamp Life: 40,000 Hours Nominal
Ingress Protection: IP67
Panel Thickness: 1-6mm or 1-10mm, (depending on mounting diameter)
Mounting Nut Torque: 5-14Nm

FEATURES & BENEFITS

- Pilot indicator light
- Multiple panel cutout sizes -- 6mm to 19mm dia.
- Multiple illumination voltage options
- Multiple LED color options
- Wire leads (150mm long) optional
- IP67 rated

PART NUMBER CONFIGURATOR

Series	Panel Cutout Diameter	Lens	Terminal	Body Finish	Lens Color	Illumination Voltage
<input type="checkbox"/> <input type="checkbox"/> <input type="checkbox"/>	<input type="checkbox"/> <input type="checkbox"/>	<input type="checkbox"/>	<input type="checkbox"/>	<input type="checkbox"/>	<input type="checkbox"/>	<input type="checkbox"/>
PVL	06 - 6mm Dia. 08 - 8mm Dia. 10 - 10mm Dia. 12 - 12mm Dia. 14 - 14mm Dia. 16 - 16mm Dia. 19 - 19mm Dia.	F - Flat	L - Solder Lug W - Wire Leads 150mm	S - Stainless Steel 1 - Black	1 - Red 3 - Green 4 - Blue	1 - Base Voltage* 3 - 6V 4 - 12V 5 - 24V 6 - 110V

NOTES:

* Base voltage on LEDs:
 1.8V @ 20mA for Red, Yellow and Orange LED colors
 2.8V @ 20mA for Blue, Green and White LED colors

Specifications subject to change without notice 12.17.2020



E-SWITCH®

www.e-switch.com

800.867.2717

1

PVL SERIES PILOT INDICATOR

BODY DIMENSIONS

PVL06

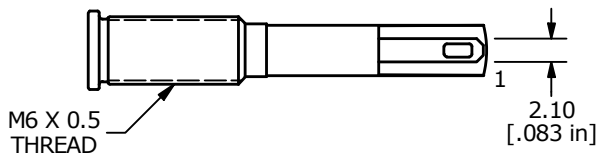
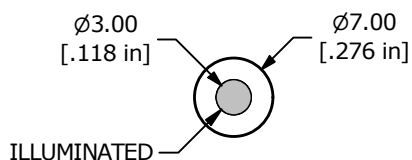
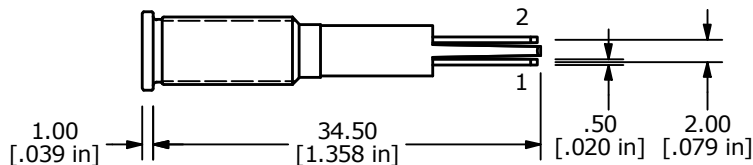
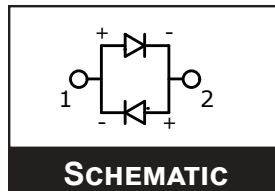
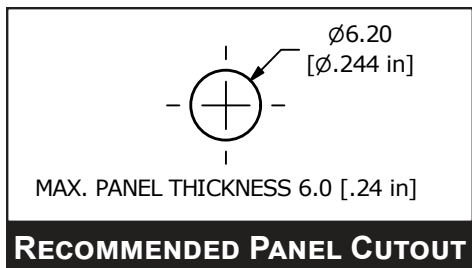

PVL08

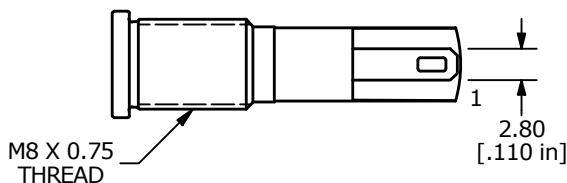
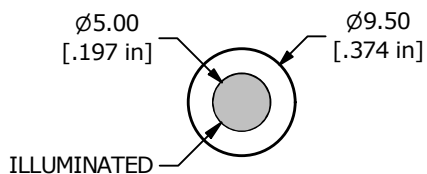
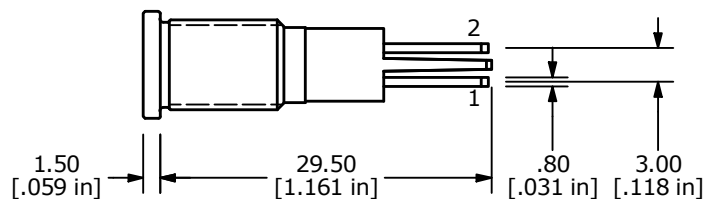
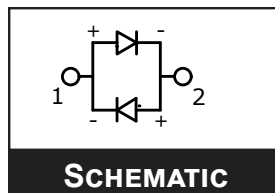
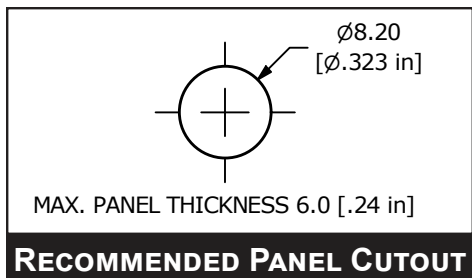

PVL SERIES PILOT INDICATOR

BODY DIMENSIONS

PVL10

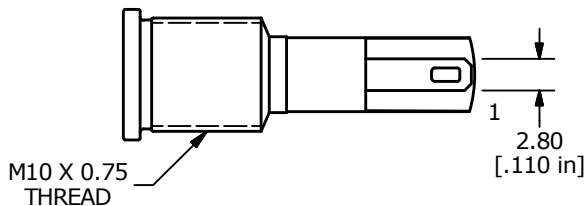
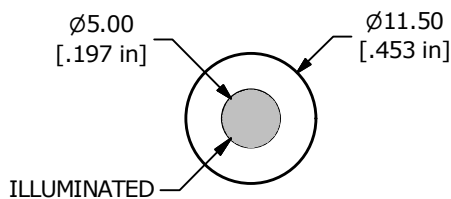
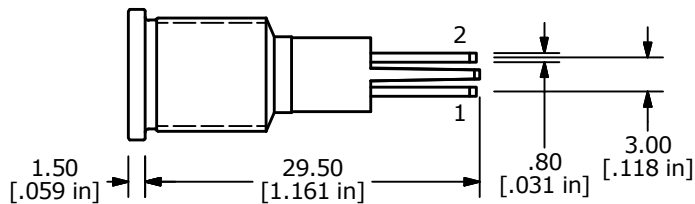
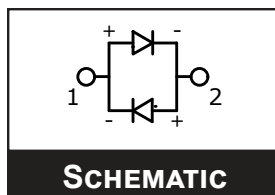
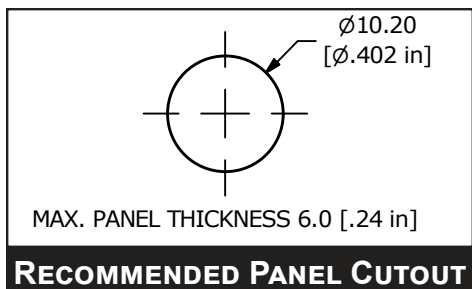

PVL12

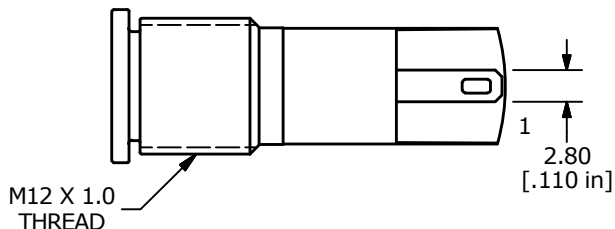
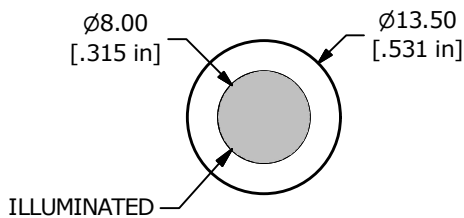
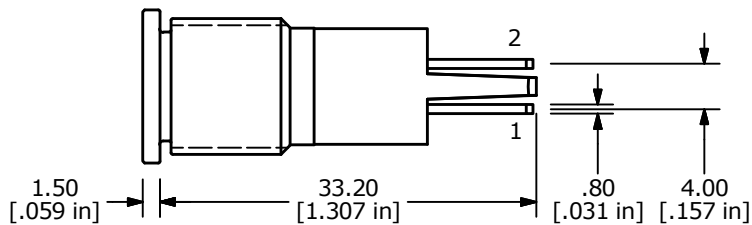
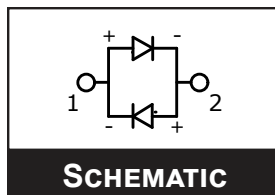
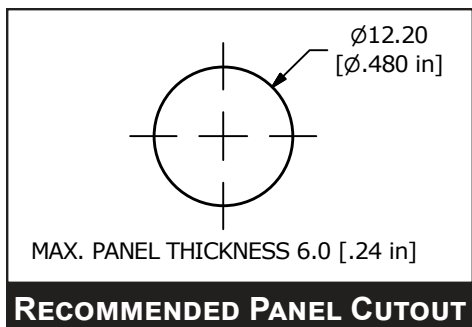

PVL SERIES PILOT INDICATOR

BODY DIMENSIONS

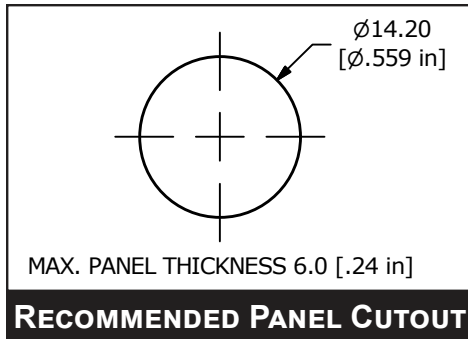

PVL14

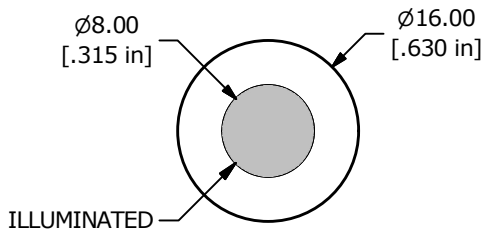
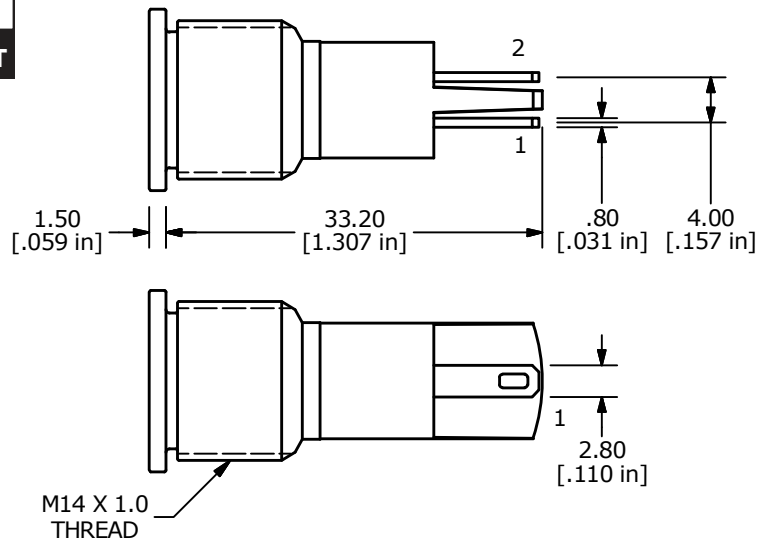
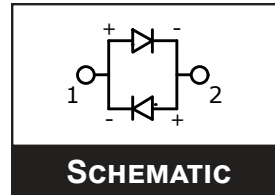

PVL16

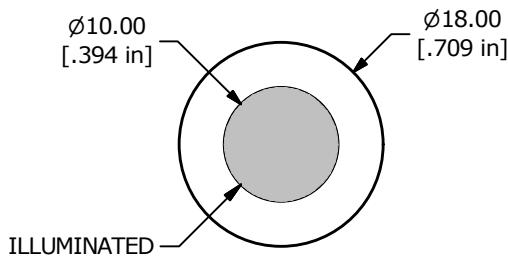
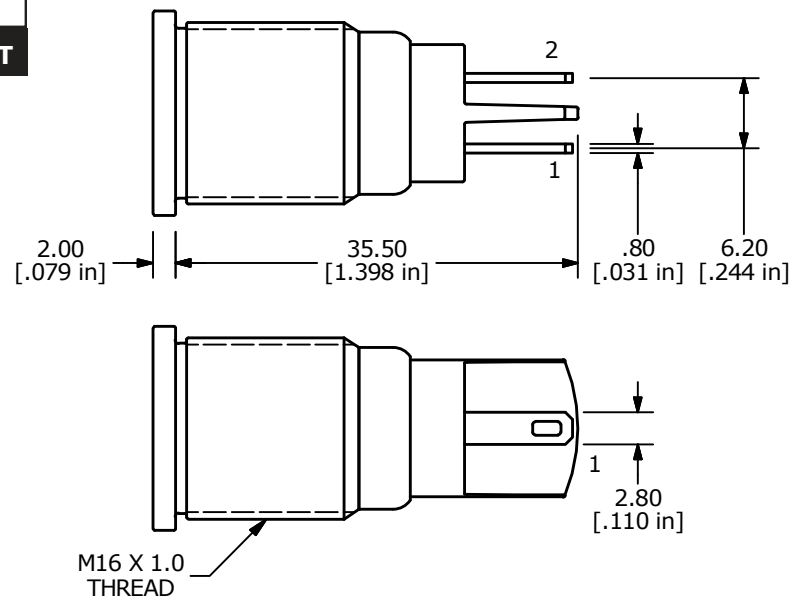
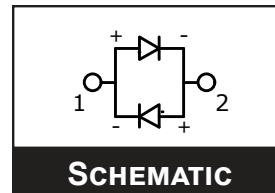
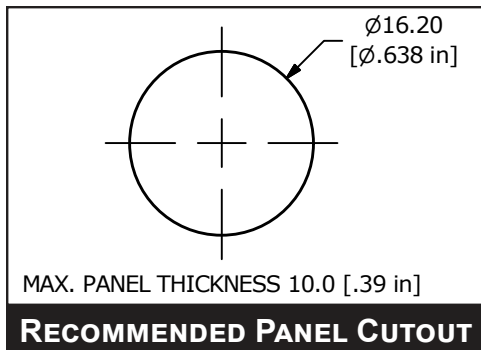

ANTI-VANDAL
 SWITCHES
 DETECTOR
 SWITCHES
 DIP
 SWITCHES
 KEYLOCK
 SWITCHES
 NAVIGATION
 SWITCHES
 PUSHBUTTON
 SWITCHES
 ROCKER
 SWITCHES
 ROTARY
 SWITCHES
 SLIDE
 SWITCHES
 SNAP ACTION
 SWITCHES
 TACTILE
 SWITCHES
 TOGGLE
 SWITCHES
 CAP
 OPTIONS

PVL SERIES PILOT INDICATOR

BODY DIMENSIONS

PVL19

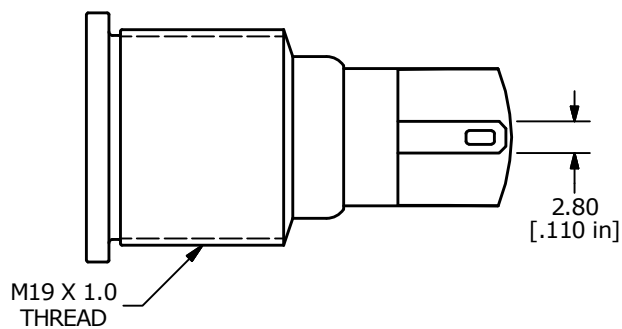
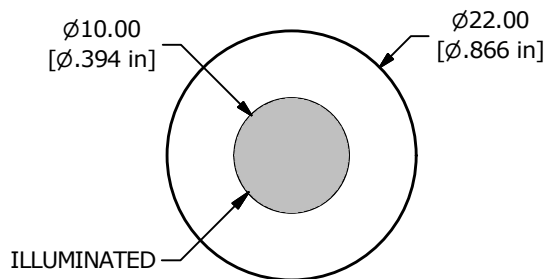
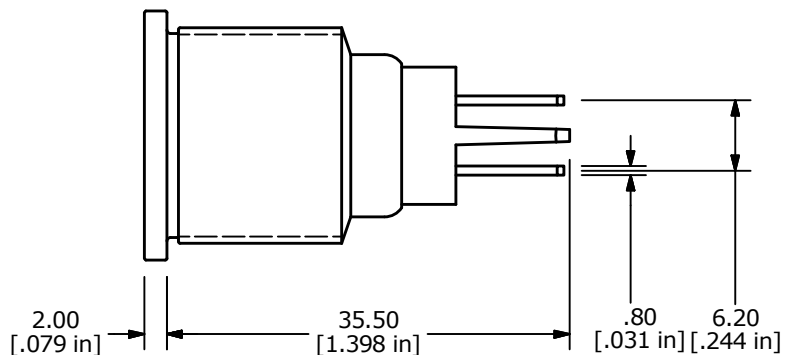
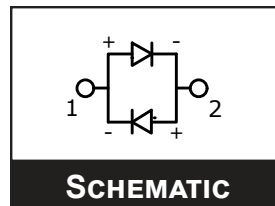
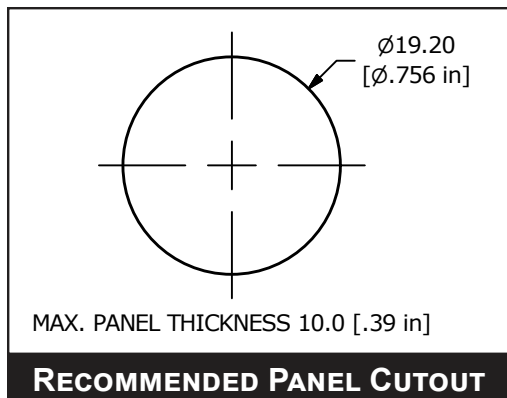

PVL SERIES PILOT INDICATOR

WIRE LEAD OPTIONS

PVL06

ADAPTER	WIRE	LENGTH
SW1-1	WIRE, 24 AWG AWM UL1061, BLACK	150.0 [5.9 in]
SW1-2	WIRE, 24 AWG AWM UL1061, BLACK	150.0 [5.9 in]

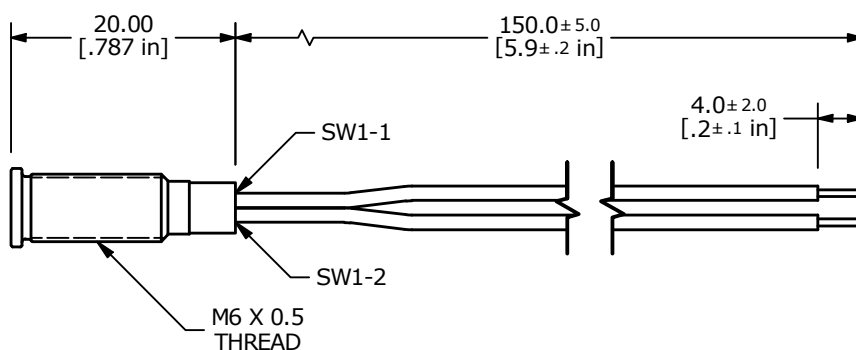
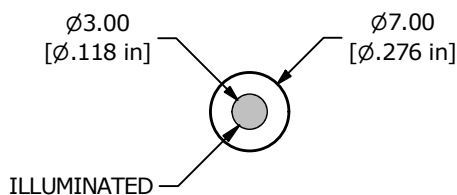
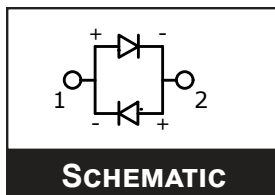
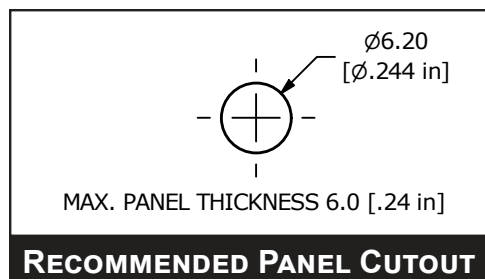

PVL08

ADAPTER	WIRE	LENGTH
SW1-1	WIRE, 24 AWG AWM UL1007, BLACK	150.0 [5.9 in]
SW1-2	WIRE, 24 AWG AWM UL1007, BLACK	150.0 [5.9 in]

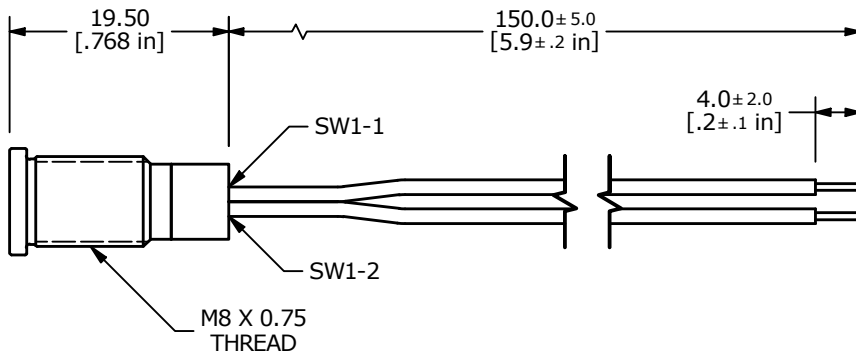
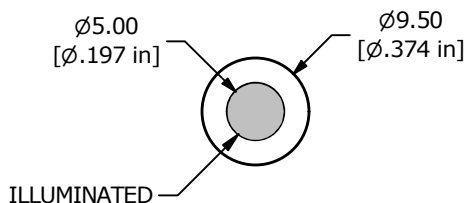
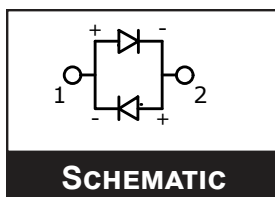
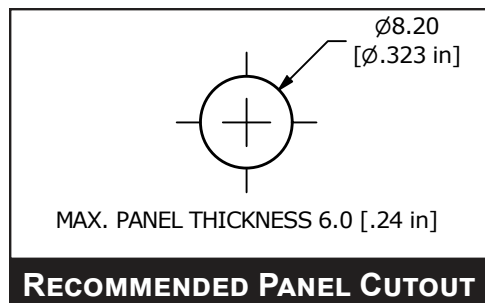

PVL SERIES PILOT INDICATOR

WIRE LEAD OPTIONS

PVL10

ADAPTER	WIRE	LENGTH
SW1-1	WIRE, 24 AWG AWM UL1007, BLACK	150.0 [5.9 in]
SW1-2	WIRE, 24 AWG AWM UL1007, BLACK	150.0 [5.9 in]

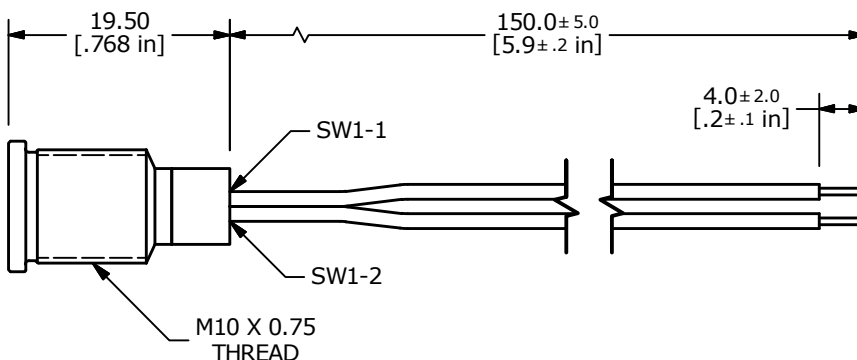
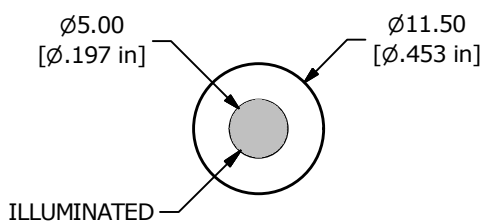
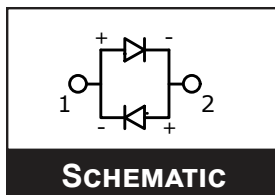
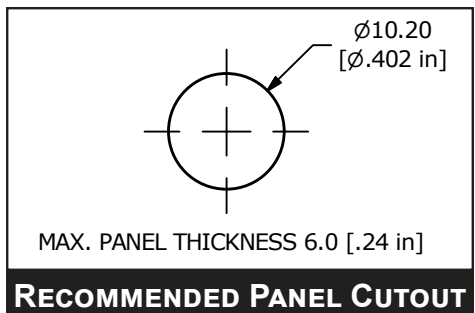

PVL12

ADAPTER	WIRE	LENGTH
SW1-1	WIRE, 24 AWG AWM UL1007, BLACK	150.0 [5.9 in]
SW1-2	WIRE, 24 AWG AWM UL1007, BLACK	150.0 [5.9 in]

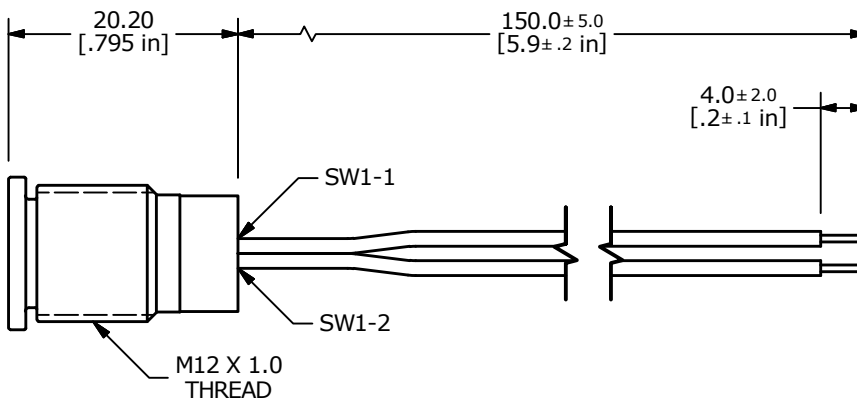
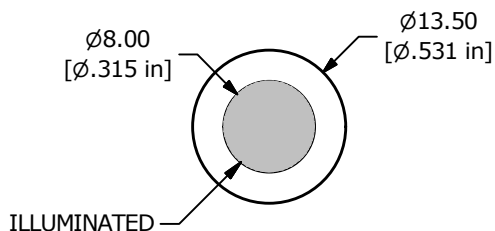
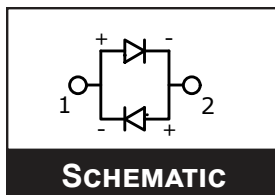
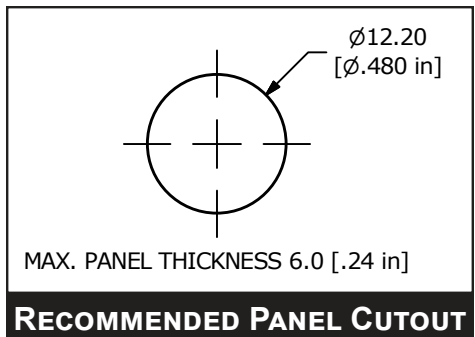

PVL SERIES PILOT INDICATOR

WIRE LEAD OPTIONS

PVL14

ADAPTER	WIRE	LENGTH
SW1-1	WIRE, 24 AWG AWM UL1007, BLACK	150.0 [5.9 in]
SW1-2	WIRE, 24 AWG AWM UL1007, BLACK	150.0 [5.9 in]

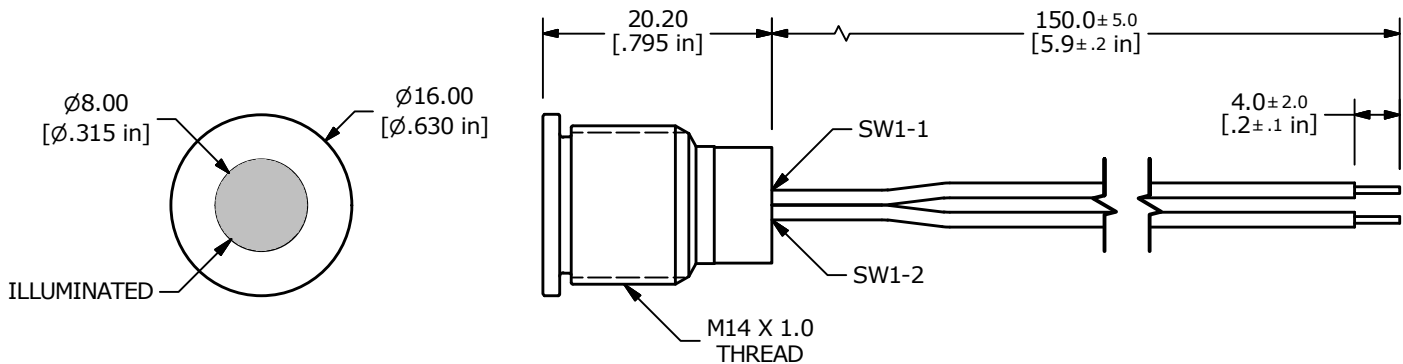
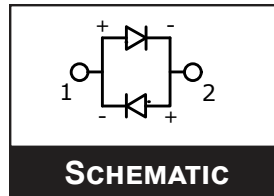
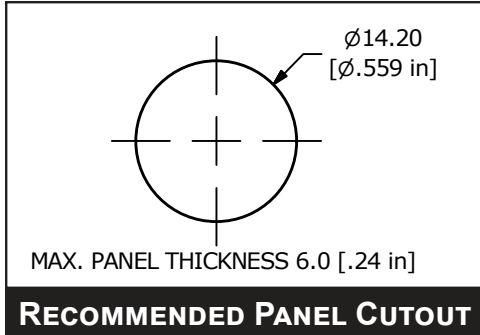

PVL16

ADAPTER	WIRE	LENGTH
SW1-1	WIRE, 24 AWG AWM UL1007, BLACK	150.0 [5.9 in]
SW1-2	WIRE, 24 AWG AWM UL1007, BLACK	150.0 [5.9 in]

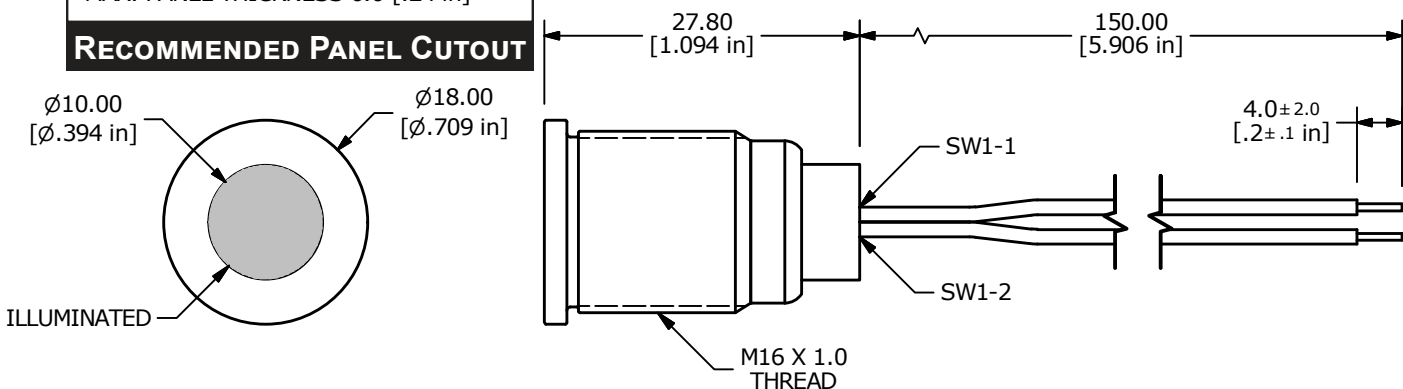
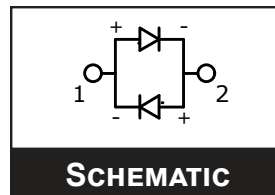
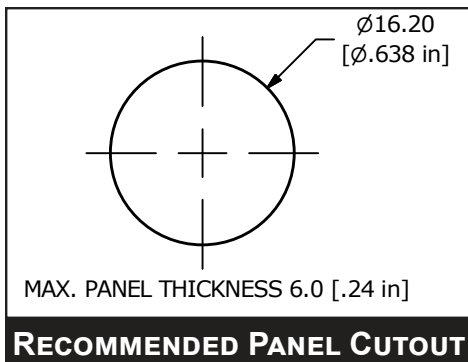

ANTI-VANDAL SWITCHES
 DETECTOR SWITCHES
 DIP SWITCHES
 KEYLOCK SWITCHES
 NAVIGATION SWITCHES
 PUSHBUTTON SWITCHES
 ROTARY SWITCHES
 ROTARY SWITCHES
 SLIDE SWITCHES
 SNAP ACTION SWITCHES
 TACTILE SWITCHES
 TOGGLE SWITCHES
 CAP OPTIONS

PVL SERIES PILOT INDICATOR

WIRE LEAD OPTIONS

PVL19

ADAPTER	WIRE	LENGTH
SW1-1	WIRE, 24 AWG AWM UL1007, BLACK	150.0 [5.9 in]
SW1-2	WIRE, 24 AWG AWM UL1007, BLACK	150.0 [5.9 in]

