

REVISIONS				
P	LTR	DESCRIPTION	DATE	APVD
F1		Note 1 Plating 0.76 µm added(PdNi+Au)	10JUL2023	BGC PS

POS. PER ROW "n"	L±0.4	PART NO.
2	4.58	-2
3	7.12	829540 -3
4	9.66	829540 -4
5	12.20	829540 -5 OBSOLETE
9	22.36	829540 -9
17	42.68	1- 829540 -7

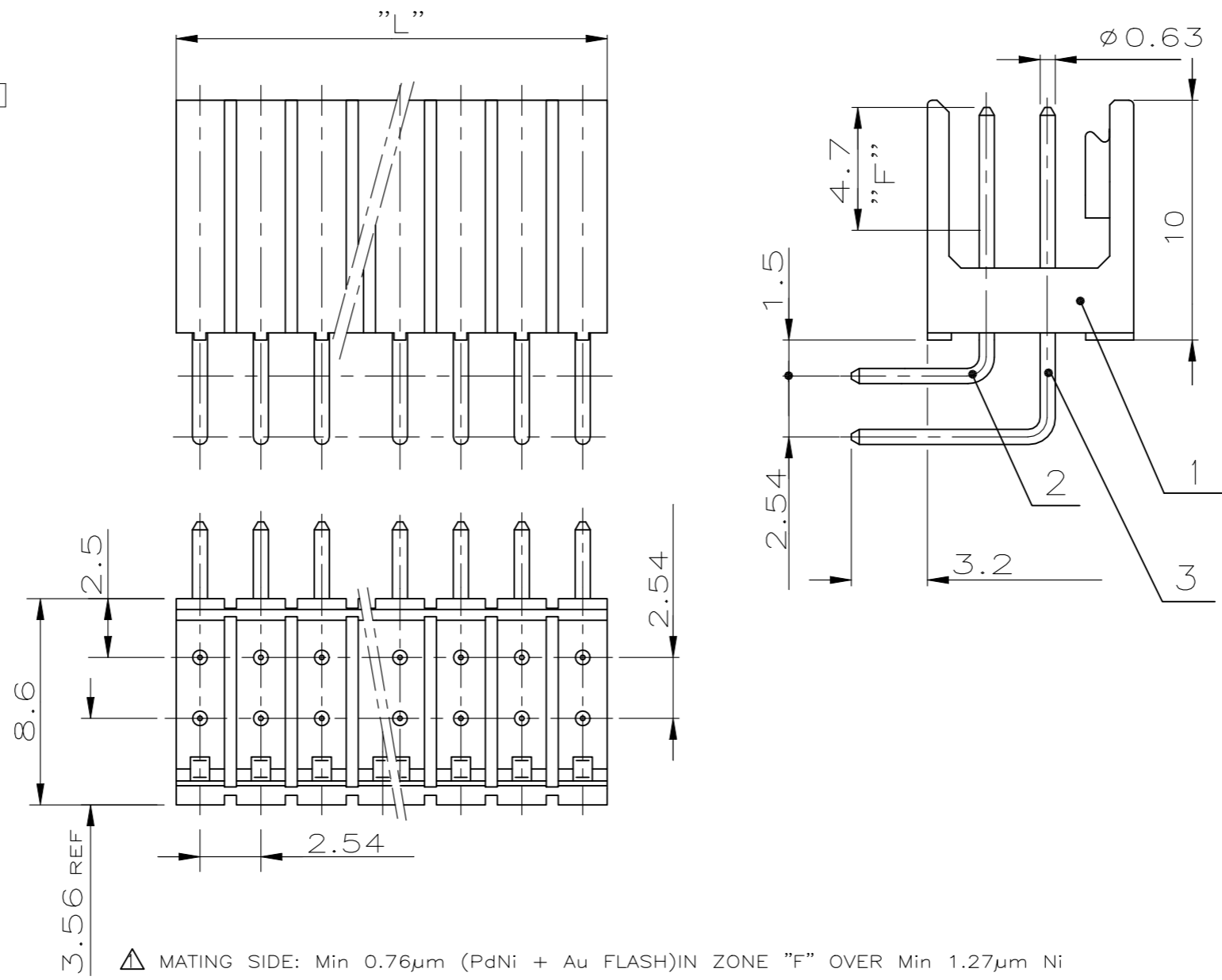

△ MATING SIDE: Min 0.76µm (PdNi + Au FLASH) IN ZONE "F" OVER Min 1.27µm Ni
 (Alternative plating - Min 0.76µm Au OVER Min 1.27µm Ni)
 SOLDER SIDE: MIN 3.0µm TIN OVER Min 1.27µm NICKEL

3	CONTACT PIN KONTAKTSTIFT	CuZn	△
2	CONTACT PIN KONTAKTSTIFT	CuZn	△
1	PIN HOUSING STIFTGEHÄUSE	PA 4/6	BLACK SCHWARZ
POS.	BENENNUNG EINZELTEIL	WERKSTOFF	OBERFLÄCHE
[ITEM NO.]	[DESCRIPTION]	[MATERIAL]	FARBE [FINISH]

THIS DRAWING IS A CONTROLLED DOCUMENT.

DIMENSIONS: ±0.2mm
mm

TOLERANCES UNLESS OTHERWISE SPECIFIED:

0 PLC	± -
1 PLC	± -
2 PLC	± -
3 PLC	± -
4 PLC	± -
ANGLES	± -
FINISH	± -

MATERIAL: SEE TABLE

DWN MÜLLER 12FEB1990
 CHK SCHAARSCHMIDT 12FEB1990
 APVD -

NAME: AMPMODU II PIN HEADER 90 DEG, DUAL ROW

PRODUCT SPEC: 108-18012

APPLICATION SPEC: -

SIZE: A3 CAGE CODE: 00779 DRAWING NO: C-829540 RESTRICTED TO: -

WEIGHT: -

CUSTOMER DRAWING SCALE: 4:1 SHEET: 1 OF 1 REV: F1