

THIS DRAWING IS UNPUBLISHED. RELEASED FOR PUBLICATION
 © COPYRIGHT 19 BY AMP INCORPORATED. ALL RIGHTS RESERVED.

LOC	DIST	REVISIONS				
		P	LTR	DATE	DWN	APVD
G	14	0	-	08MAY97	DKS	MJS

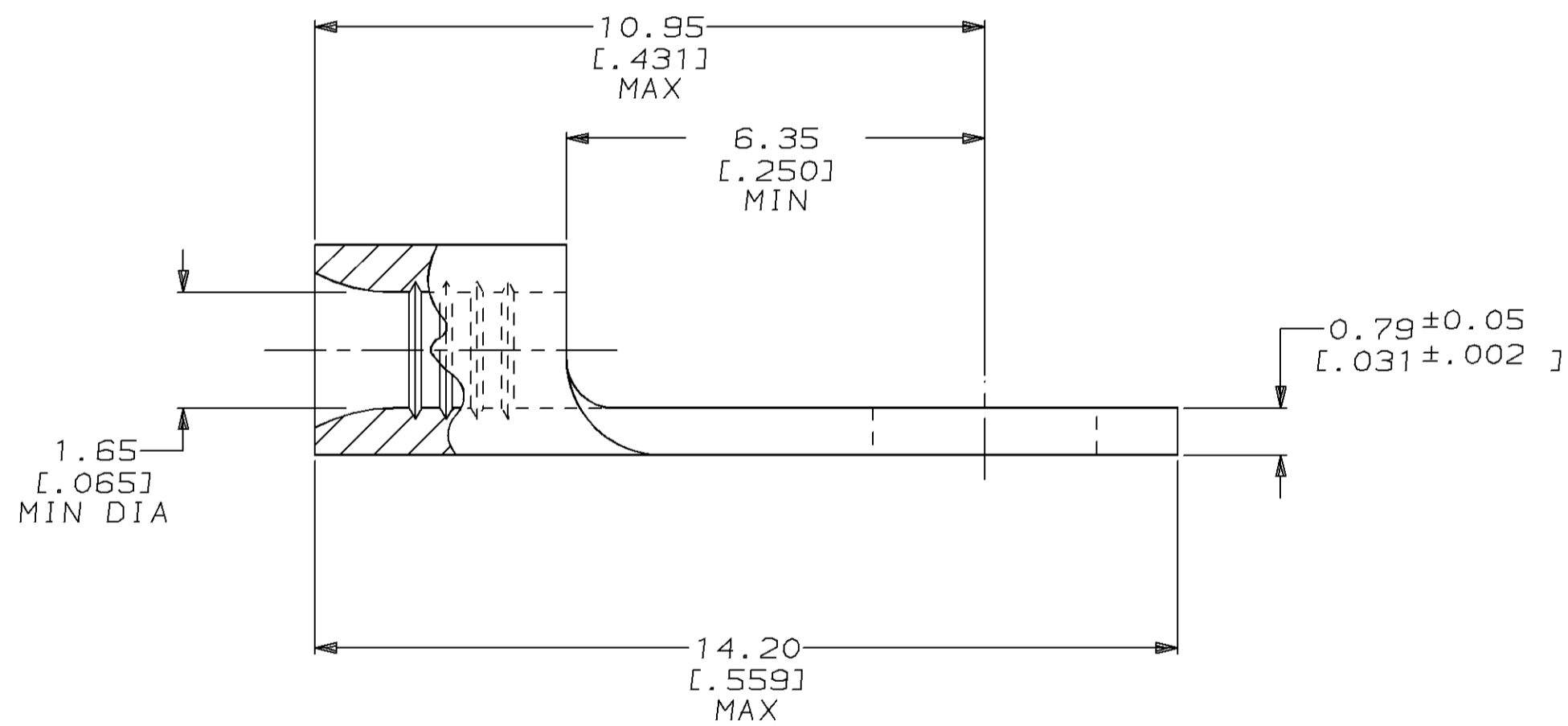
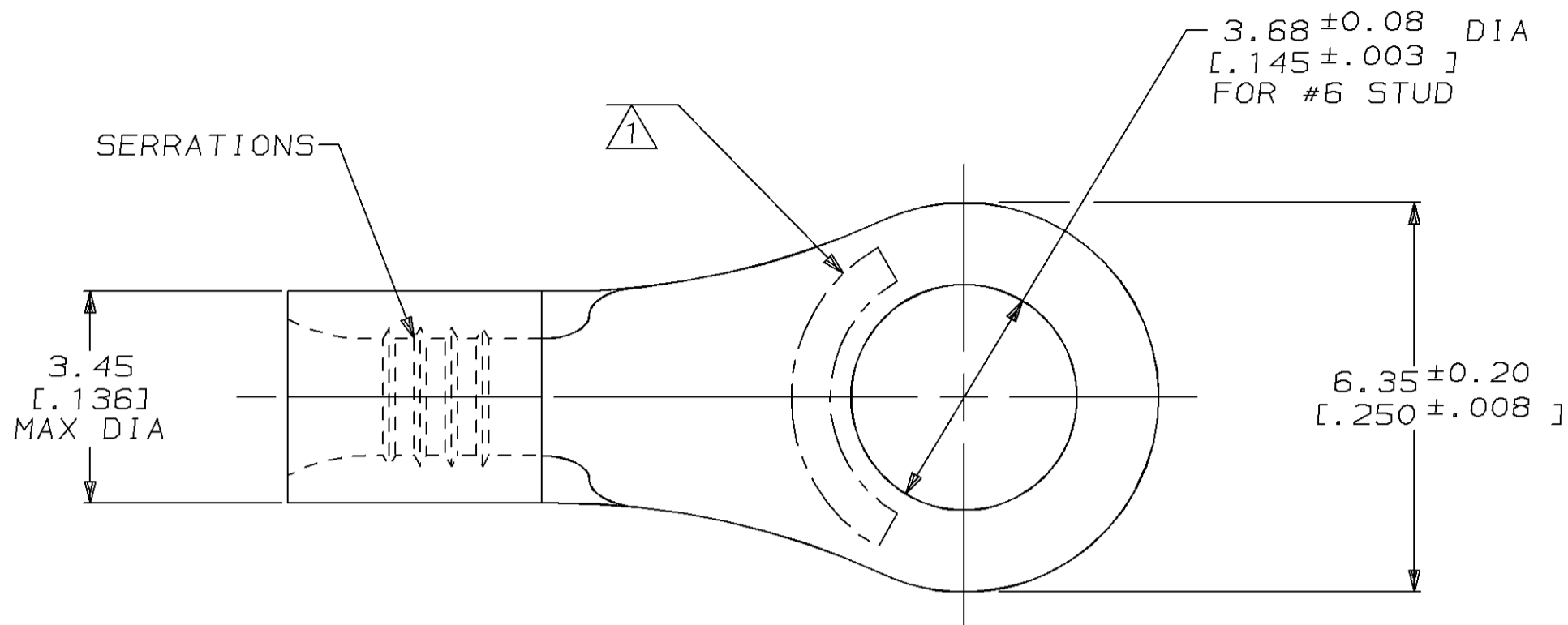

AMP WIRE RANGE	E13288 Listed
22-16 AWG STRANDED	22-16 AWG STRANDED
LR7189 Certified	MILITARY P/N AND CLASS
NOT CERTIFIED	NOT APPLICABLE

- ① STAMP AMP [] APPROX AS SHOWN
22-16 TERMINALS ARE STAMPED 22-18 IN
ACCORDANCE WITH MILITARY SPEC MIL-T-7928
COMMERCIAL WIRE RANGE IS 22-16
SEE TABLE BELOW FOR STAMPING DESIGNATION
- ② TIN PL 0.00254 [.000100] MIN THK
PER MIL-T-10727
- ③ TIN-LEAD PL 0.00254 [.000100] MIN THK
PER MIL-T-10727
- ④ GOLD PL 0.00127 [.000050] MIN THK
PER MIL-G-45204 OVER NICKEL PL
0.00076 [.000030] MIN THK PER QQ-N-290
- ⑤ NICKEL PL 0.00762 [.000300] MIN THK
PER QQ-N-290

22-18*	①-	2-51873-1
18*	②-	1-51873-9
20*	③-	1-51873-8
22-18*	④-	51873-9
22-18*	⑤-	51873-8
18*	⑥-	51873-4
20*	⑦-	51873-3
22*	⑧-	51873-2
22-18*	⑨-	51873-1
STAMPING	FINISH	AMP PART NUMBER

**AMP INCORPORATED
CUSTOMER SERVICE SYSTEMS**

RECOMMENDED OPERATING TEMPERATURE:
170°C MAX

FOR ADDITIONAL PRODUCT
INFORMATION OR COPIES OF DRAWINGS
AND TECHNICAL DOCUMENTS

PRODUCT INFORMATION CENTER
1-800-522-6752

VOLTAGE RATING:
NOT APPLICABLE

FOR APPLICATION
TOOLING INFORMATION

TOOLING ASSISTANCE CENTER
1-800-722-1111

WIRE CROSS SECTIONAL AREA RANGE:
0.26-1.65mm² [509-3,260] CIR MILS
STRANDED

FOR ORDER ENTRY

1-800-526-5142

THIS DRAWING IS A CONTROLLED DOCUMENT.

DWN DK SCHRUM 08MAY97

CHK MJ SPICER 08MAY97

APVD JL MECKLEY 08MAY97

PRODUCT SPEC

APPLICATION SPEC

WEIGHT

CUSTOMER DRAWING

AMP AMP Incorporated
Harrisburg, PA 17105-3608

**TERMINAL, RING TONGUE,
BUDGET**

SIZE A2 CAGE CODE 00779 DRAWING NO C-51873

SCALE 10:1 SHEET 1 OF 1 REV 0

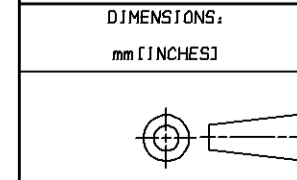

DIMENSIONS:	TOLERANCES UNLESS OTHERWISE SPECIFIED:
mm [INCHES]	
0 PLC	±
1 PLC	±
2 PLC	±0.20 [.008]
3 PLC	±
4 PLC	±
ANGLES	±
FINISH	SEE TABLE

MATERIAL COPPER
PER ASTM B-152
ANNEALED

SEE TABLE