

WT41 EVALUATION KIT

DATASHEET

Thursday, 04 August 2011

Version 1.0

Copyright © 2000-2011 Bluegiga Technologies

All rights reserved.

Bluegiga Technologies assumes no responsibility for any errors which may appear in this manual. Furthermore, Bluegiga Technologies reserves the right to alter the hardware, software, and/or specifications detailed here at any time without notice and does not make any commitment to update the information contained here. Bluegiga's products are not authorized for use as critical components in life support devices or systems.

The WRAP is a registered trademark of Bluegiga Technologies

The *Bluetooth* trademark is owned by the Bluetooth SIG Inc., USA and is licensed to Bluegiga Technologies. All other trademarks listed herein are owned by their respective owners.

VERSION HISTORY

Version	Comment
1.0	Release

TABLE OF CONTENTS

WT41 Evaluation Kit	1
Datasheet	1
1 Design Overview	5
2 Schematics	7
3 Assembly	10
4 Layout.....	11
5 Interfaces.....	15
5.1 Powering the evaluation board	15
5.2 USB.....	15
5.3 SPI	16
5.4 UART	16
5.5 PCM Codec and Audio Interface	16
5.6 PIO Configurations and Using the PIO Buttons.....	16
6 WEEE Compliance	17
7 Contact Information	18

1 Design Overview

WT41 Evaluation Kit is targeted for engineers evaluating WT41 *Bluetooth* modules and developing or prototyping *Bluetooth* systems utilizing WT41 module(s). WT41 Evaluation Kit features:

- Evaluation board for WT41 *Bluetooth* module containing
 - RS-232 serial interface
 - Switchable self powered or bus powered USB interface
 - SPI for upgrading the firmware and parameters
 - Push buttons for all the PIOs and reset
 - PCM codec (Winbond W681360SG)
 - 2 x 3,5mm audio jacks for microphone in and speaker out
 - 24 pin I/O interface (PIO2 – PIO7, UART, PCM, GND, 3V3)
 - Current measurement point

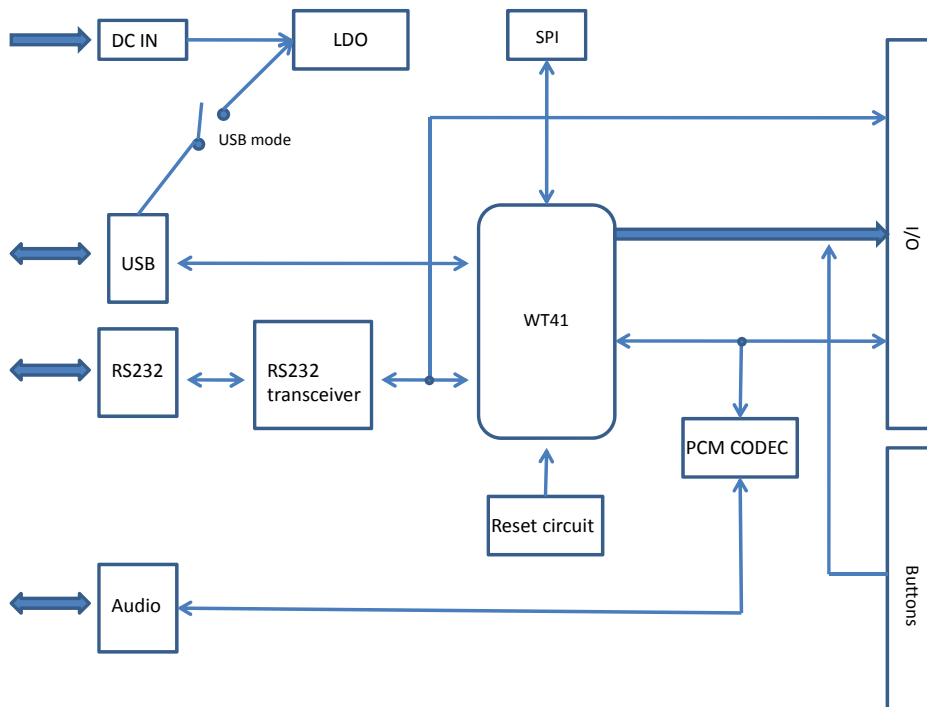

Figure 1: Block diagram of WT41 evaluation board

Please, refer to the latest WT41 data sheet for information about WT41 *Bluetooth* module. The physical outlook, schematics, assembly and the PIN configurations of the interfaces of WT41 evaluation Kit are described in this document.

WT41 Evaluation Kit is delivered with iWRAP software as default firmware. iWRAP is a simple ASCII command based interface, which enables access to various *Bluetooth* functions. A detailed description of iWRAP can be found from *iWRAP User Guide*, which can be downloaded from the Tech-forum.

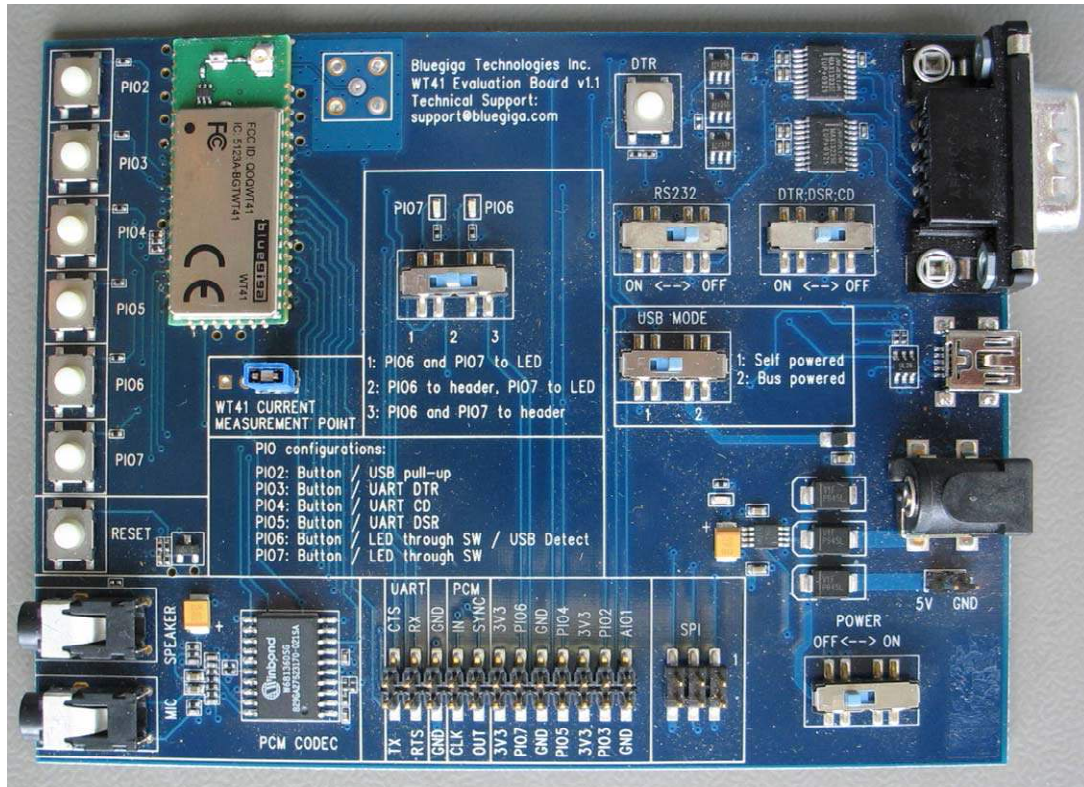

Figure 2: WT41 Evaluation Board

2 Schematics

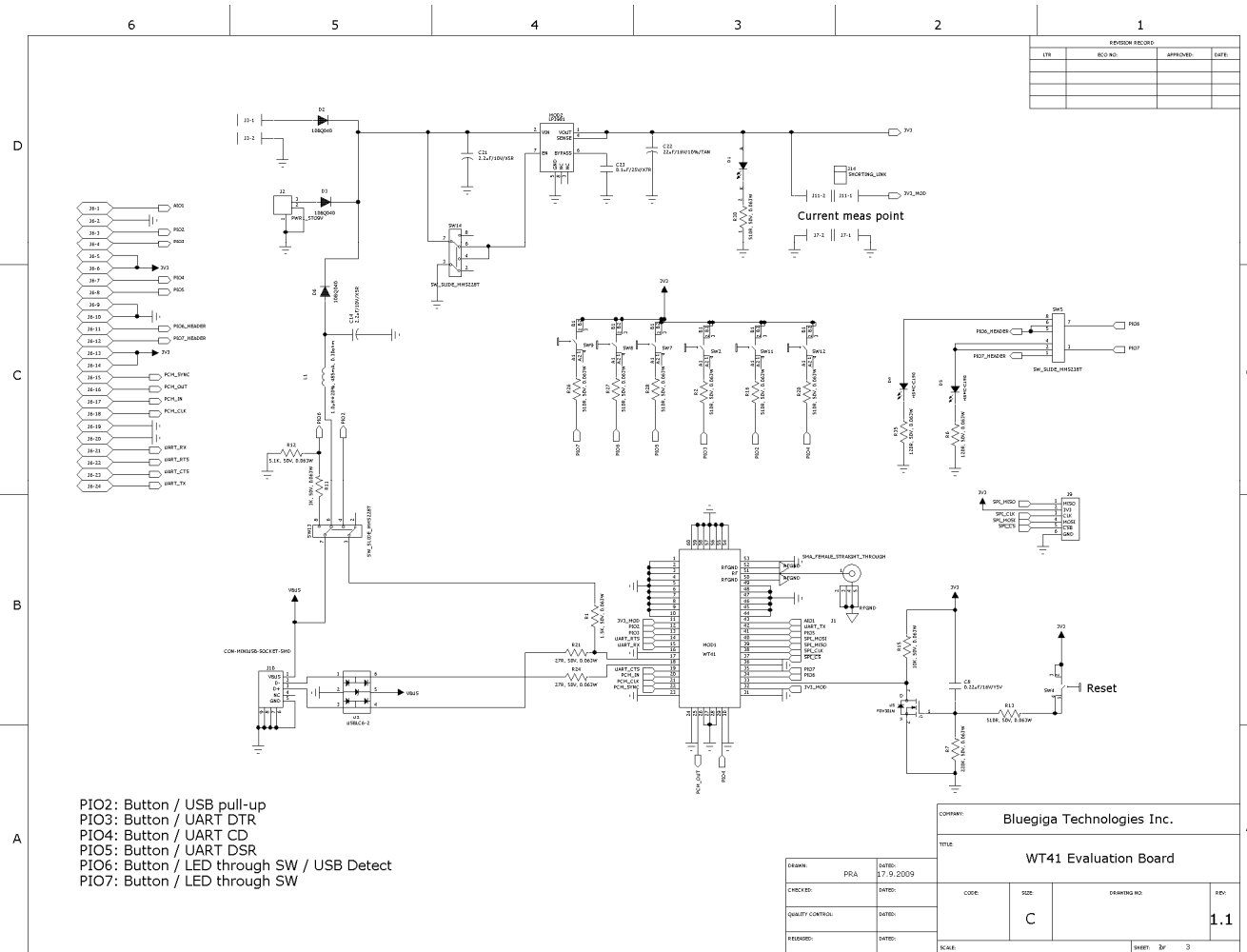

Figure 3: WT41 Evaluation Board Schematic (1/3)

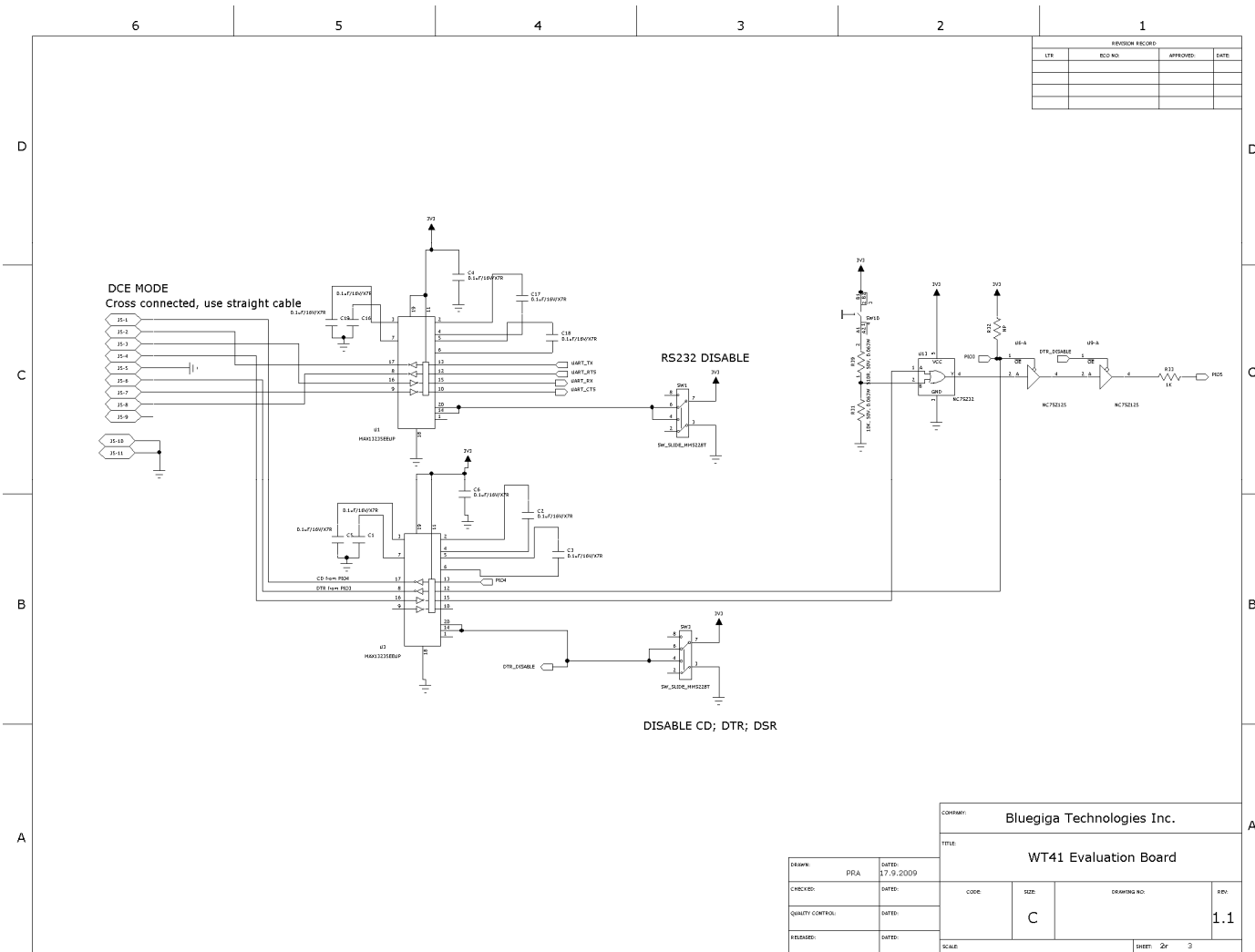

Figure 4: WT41 Evaluation Board Schematic (2/3)

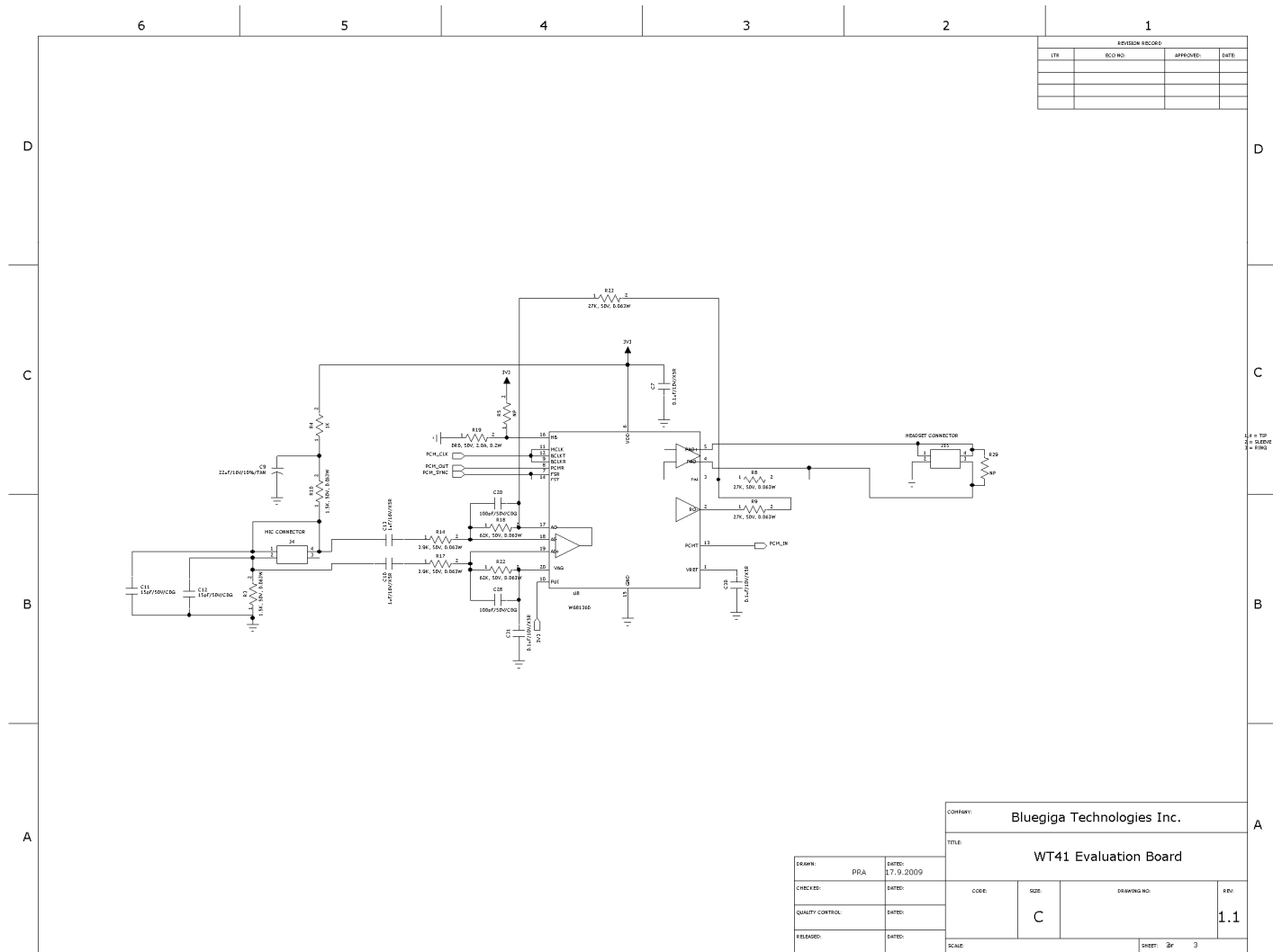

Figure 5: WT41 Evaluation Board Schematic (3/3)

3 Assembly

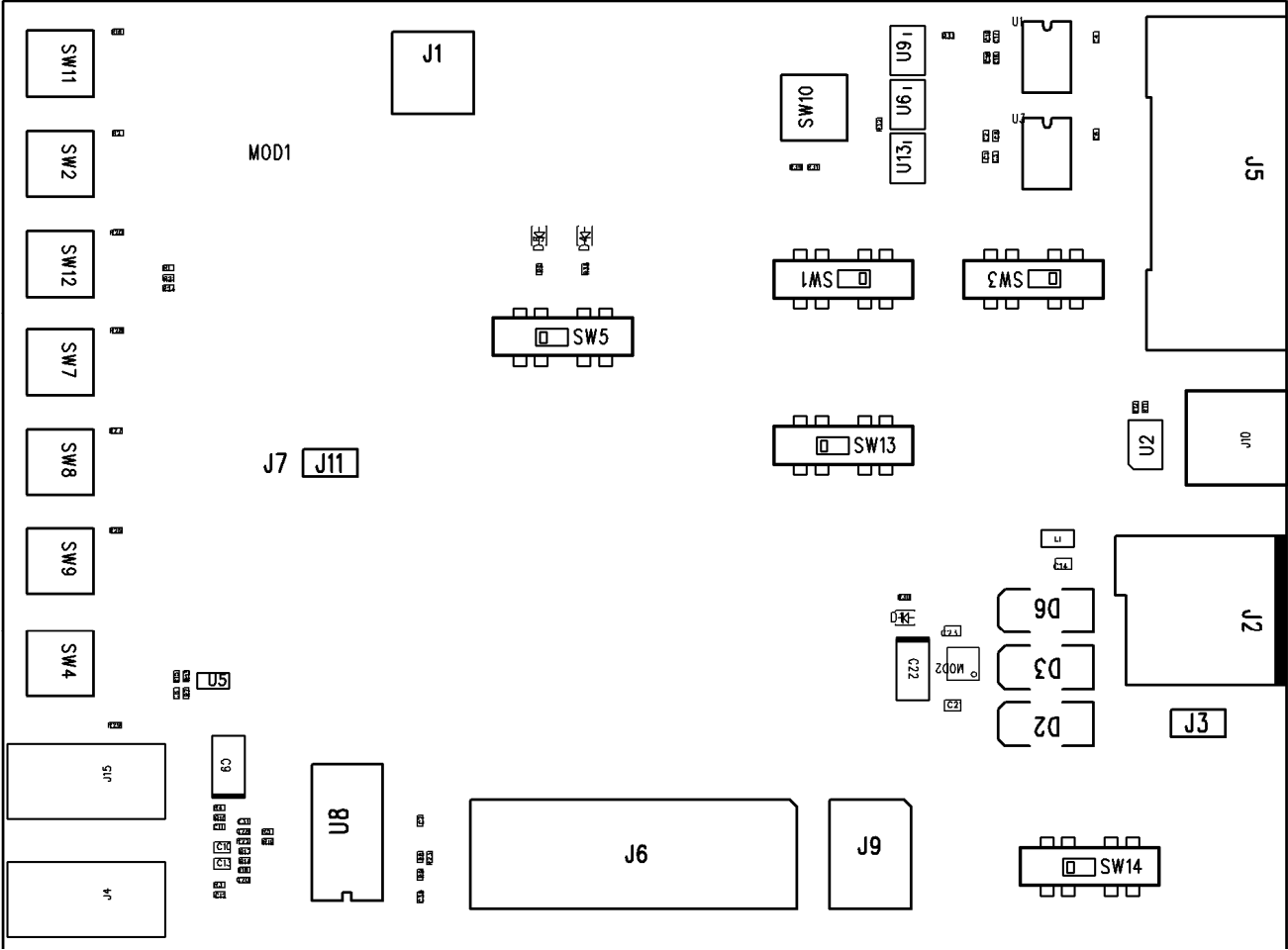

Figure 6: WT41 Evaluation Board Assembly Drawing

4 Layout

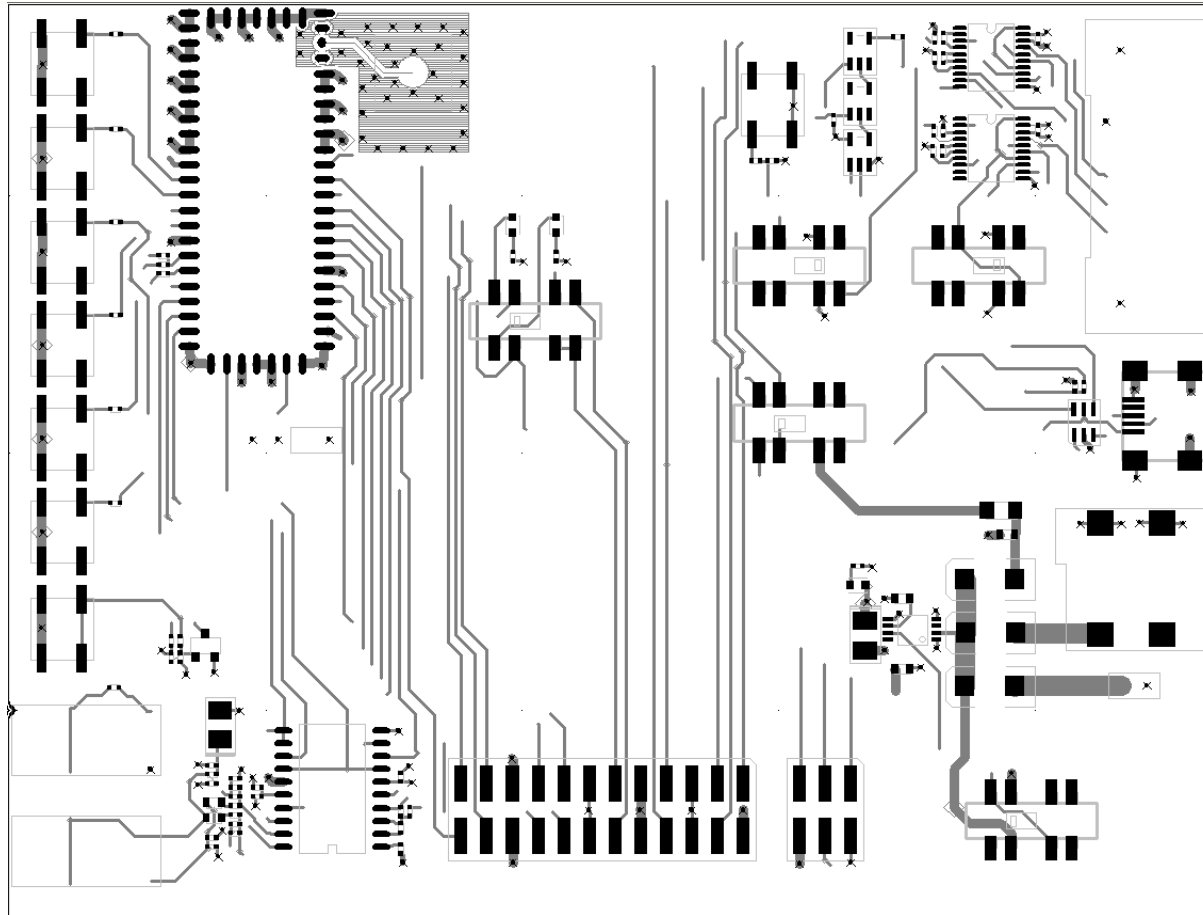

Figure 7: Top Layer Layout

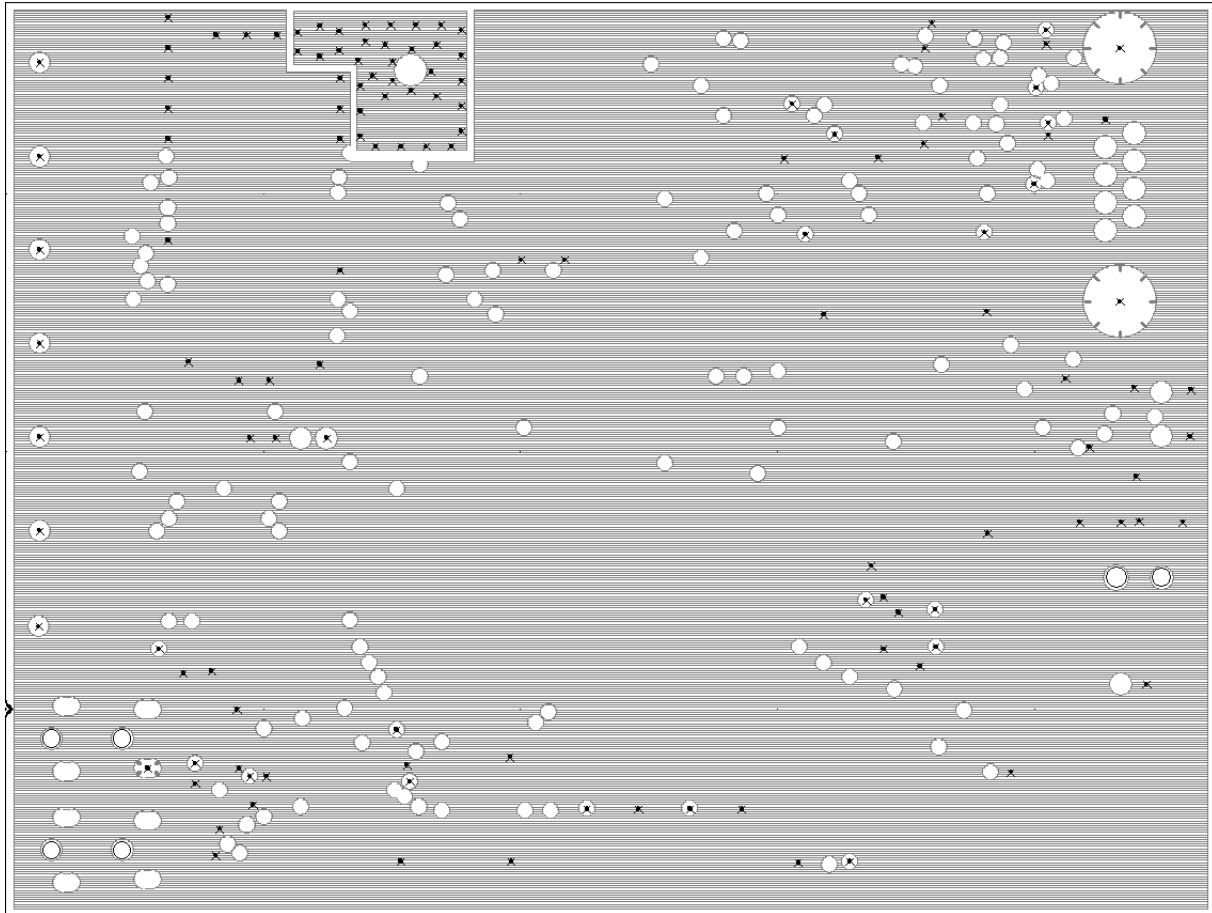

Figure 8: 2nd Layer Layout

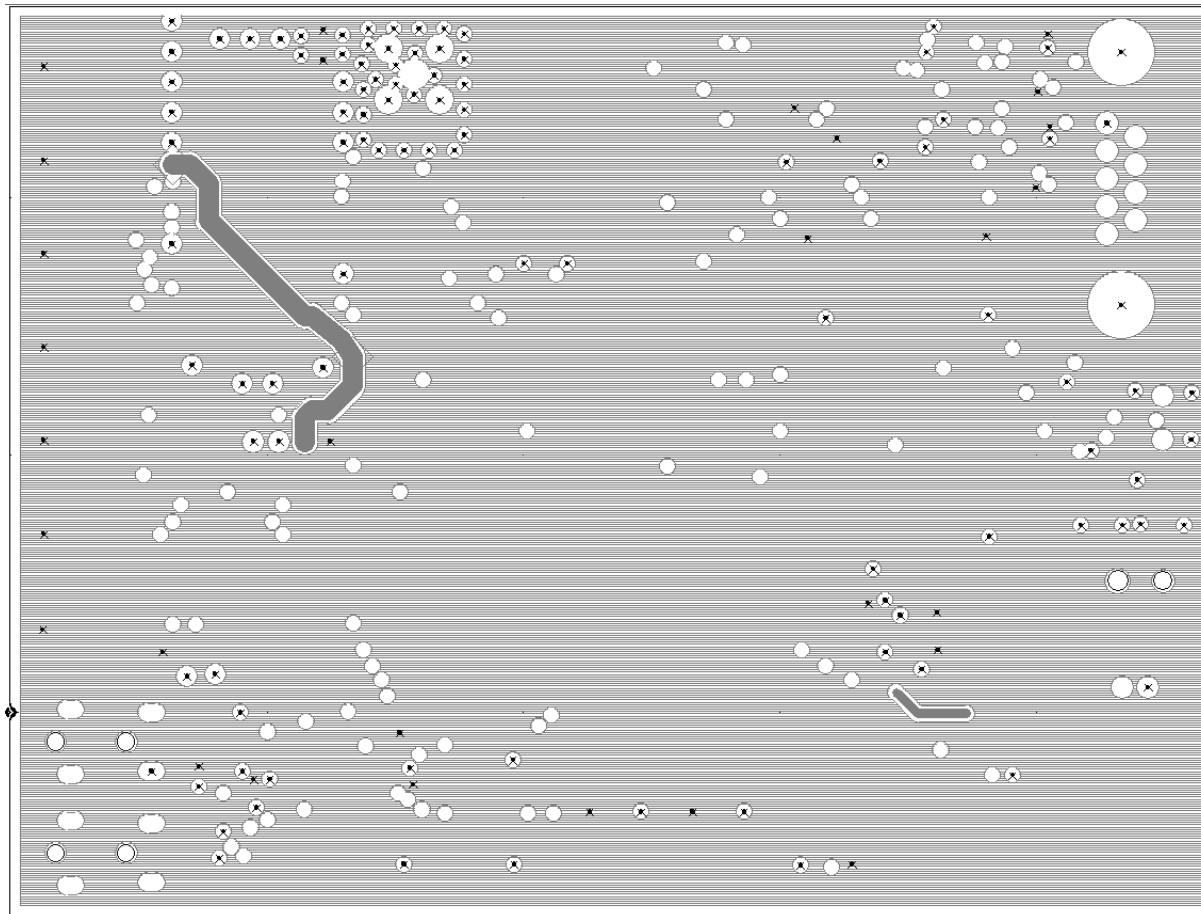

Figure 9: 3rd Layer Layout

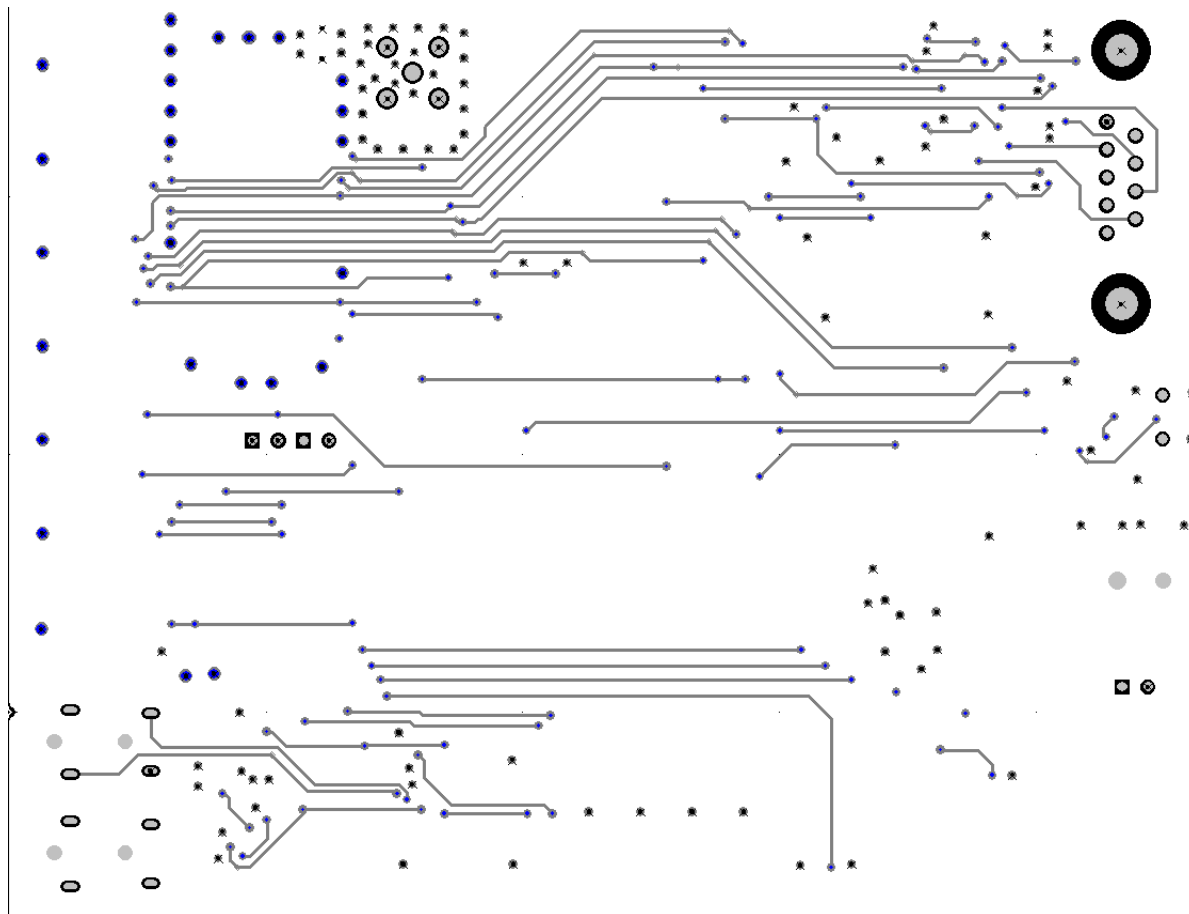

Figure 10: Bottom Layer Layout

5 Interfaces

5.1 Powering the evaluation board

The evaluation kit can be powered in three ways:

1. Connect 5 V DC to J2. 100 – 240 V AC to 5 V DC switching power supply is delivered with the evaluation kit.
2. Connect 5 V DC to the header J3 or 3,3 V DC to at least one of the 24 pin header's 3V3 pins
3. Connect 5 V DC through the USB interface and set SW13 for bus-powered mode

5.2 USB

WT41 can be configured to operate in a bus-powered or in a self powered mode. See the datasheet of WT41 and the HW design guide of WT41 for more detailed information. In the evaluation board, the switch SW13 is used to define the hardware configuration. For the related software configuration use PSTool software to set the required PSKEYs. Relevant PSKEYs are:

PSKEY name	Description
PSKEY_HOST_INTERFACE	Set to 2 to enable HCI-USB mode immediately at boot (otherwise refer to BOOT 3 command of iWrap firmware)
PSKEY_HOST_INTERFACE_PIO_USB	Set to 2 – 7 to force the USB interface when that PIO line is pulled high, overriding PSKEY_HOST_INTERFACE
PSKEY_USB_MAX_POWER	Maximum current drawn by the device in units of 2 mA. This must be set for WT41 always since WT41 peak currents are over 100 mA
PSKEY_USB_PIO_VBUS	A values between 2 and 7 indicate the PIO line to be used to monitor USB VBUS. If key is not present then firmware assumes that USB VBUS is always present. Keep not present for bus-powered device. In the evaluation kit USB detection is connected to PIO6.
PSKEY_USB_ATTRIBUTE_POWER	Change to zero for bus-powered device
PSKEY_USB_PIO_PULLUP	A values between 2 and 7 indicate the PIO line to be used to enable and disable USB D+/D- pull-up resistor. Setting to 16 enables the internal pull-up to be used for bus-powered device. In the evaluation PIO2 is dedicated for USB pull-up resistor.

Table 1: USB Configuration Settings

NOTE: The evaluation kit is only for evaluation purposes for the module and is not guaranteed to be 100% USB compliant. For example the power on LED is always on when VDD is present and thus the kit will not meet the USB regulations for the suspend current. See the HW design guide for USB design considerations.

5.3 SPI

SPI interface is connected to J9 and can be used for firmware and parameter updates

5.4 UART

The UART interface is available through 3 Mbps RS232 transceivers (MAX13235EEUP) from J5. UART signals are also available in the header J6 which is connected directly to the pins of the module. UART transceiver can be disabled using SW1 and SW3. Setting these to position OFF sets the transceivers to high impedance enabling the use of the signals through the header J6.

5.5 PCM Codec and Audio Interface

The audio interface is available through 3.5mm jack connectors. The PCM codec is a linear 13 bit W681360.

5.6 PIO Configurations and Using the PIO Buttons

All the PIOs are available on the push buttons. One should however note that the PIOs are also used in other purposes in the board. Following table shows the PIO configurations in the evaluation board and instructions for using the buttons

PIO line	HW connection in the evaluation board	Switch position in order to use the button
PIO2	USB pull-up	SW13 (USB MODE) to position 1: self-powered
PIO3	UART DTR	SW3 (DISABLE DTR;DSR;CD) to position OFF
PIO4	UART CD	SW3 (DISABLE DTR;DSR;CD) to position OFF
PIO5	UART DSR	SW3 (DISABLE DTR;DSR;CD) to position OFF
PIO6	LED through SW5 / USB detect	SW5 to position 2 or 3 (PIO6 to header) and SW13 (USB MODE) to position 1: self-powered
PIO7	LED through SW5	SW5 to position 3 (PIO7 to header)

Table 2: PIO Configurations

6 WEEE Compliance



The crossed-out wheeled bin means that within the European Union the product must be taken to separate collection at the product end-of-life. Do not dispose of these products as unsorted municipal waste.

7 Contact Information

Sales: sales@bluegiga.com

Technical support: support@bluegiga.com
<http://www.bluegiga.com/techforum/>

Orders: orders@bluegiga.com

Head Office / Finland:

Phone: +358-9-4355 060

Fax: +358-9-4355 0660

Street Address:

Sinikalliontie 5A

02630 ESPOO

FINLAND

Postal address:

P.O. BOX 120

02631 ESPOO

FINLAND

Sales Office / USA:

Phone: (781) 556-1039

Bluegiga Technologies, Inc.

99 Derby Street, Suite 200 Hingham, MA 02043