

MINI MCR-SL-UI-2I

Configurable signal duplicator



Data sheet
102382_en_03

© PHOENIX CONTACT 2012-05-02

1 Description

The MINI MCR-SL-UI-2I(-SP)(-NC) configurable signal duplicator is used to electrically isolate, condition, amplify, and filter standard analog signals.

The standard analog signals 0...20 mA, 4...20 mA, 0...10 V or 1...5 V can be selected on the input side. On the output side there are two electrically isolated current outputs that can be set independently of one another with a 0...20 mA or 4...20 mA signal (4-way isolation).

The DIP switches, which can be accessed on the side of the housing, are used to configure the input and output signal ranges.

The power supply (19.2...30 V DC) can be supplied either via connection terminal blocks "7"/"8" on the modules or in conjunction with the DIN rail bus connector. Please refer to the section titled "Power supply" for more information.

Features

- Configurable 4-way isolating amplifier
- Electrically isolated signal duplication
- Approval for Ex-zone 2 (nA)
- Screw or spring-cage connection can be provided



Attention: Correct usage in potentially explosive areas

The module is a category 3 item of electrical equipment. It is absolutely vital to follow the instructions provided here during installation and observe the information in the "Safety regulations and installation notes".



Make sure you always use the latest documentation.

It can be downloaded from the product at www.phoenixcontact.net/catalog.



This data sheet is valid for all products listed on the following page:

2	Table of contents	
1	Description	1
2	Table of contents	2
3	Ordering data	3
	3.1 Order key	3
4	Technical data	4
5	Safety regulations and installation notes.....	6
	5.1 Installation notes	6
	5.2 Installation in the Ex area (zone 2).....	6
6	Installation	7
	6.1 Connection notes	7
	6.2 Structure	7
	6.3 Block diagram.....	7
	6.4 Power supply.....	7
	6.5 Assembly.....	8
	6.6 Connecting the wires	8
7	Configuration	9
8	Diagnostics LED	9
9	Limiting behavior of the analog outputs	10

3 Ordering data

Description	Type	Order No.	Pcs. / Pkt.
MCR 4-way signal duplicator for the electrical isolation and doubling of analog signals with screw connection, order configuration	MINI MCR-SL-UI-2I	2864794	1
MCR 4-way signal duplicator for electrical isolation and doubling of analog signals with spring-cage connection, order configuration	MINI MCR-SL-UI-2I-SP	2864804	1
4-way signal duplicator for electrical isolation and duplication of analog signals with screw connection, standard configuration	MINI MCR-SL-UI-2I-NC	2864176	1
MCR 4-way signal duplicator for electrical isolation and doubling of analog signals with spring-cage connection, standard configuration	MINI MCR-SL-UI-2I-SP-NC	2864189	1
Accessories	Type	Order No.	Pcs. / Pkt.
DIN rail connector (TBUS), 5-pos., for bridging the supply voltage, can be snapped onto NS 35/... DIN rails according to EN 60715	ME 6,2 TBUS-2 1,5/5-ST-3,81 GN	2869728	10
MCR power terminal block for supplying several MINI Analog modules via the DIN rail connectors, with screw connection, current consumption up to max. 2 A	MINI MCR-SL-PTB	2864134	1
MCR power terminal block for supplying several MINI-ANALOG modules via the DIN rail connectors, with spring-cage connection, current consumption up to max. 2 A	MINI MCR-SL-PTB-SP	2864147	1
DIN rail power supply unit, primary-switched mode, slim design, output: 24 V DC / 1.5 A	MINI-SYS-PS-100-240AC/24DC/1.5	2866983	1
DIN rail power supply unit, primary-switched mode, slim design, output: 24 V DC / 1.5 A, ATEX approval	MINI-PS-100-240AC/24DC/1.5/EX	2866653	1
Fold up transparent cover for MINI MCR modules with additional labeling option using insert strips and flat Zack marker strip 6.2 mm	MINI MCR DKL	2308111	10
Label for extended marking of MINI MCR modules in connection with the MINI MCR-DKL	MINI MCR-DKL-LABEL	2810272	10

3.1 Order key

(standard configuration entered as example)

Order No.	Input	Output combination	Behavior of the analog outputs	Factory calibration certificate
2864794	IN03	A	0	NONE
2864794 ≙ ...-UI-2I	IN01 ≙ 0 ... 20 mA IN02 ≙ 4 ... 20 mA IN03 ≙ 0 ... 10 V	A B C	0 ≙ Analog behavior 1 ≙ Limitation	NONE ≙ Without factory calibration YES ≙ With factory calibration certificate (a fee is charged)
2864804 ≙ ...-UI-2I-SP	IN06 ≙ 1 ... 5 V			YESPLUS ≙ Factory calibration certificate with 5 measuring points (a fee is charged)

Explanation of the output combination:

	Output 1	Output 2
A	0 ... 20 mA	0 ... 20 mA
B	0 ... 20 mA	4 ... 20 mA
C	4 ... 20 mA	4 ... 20 mA

4 Technical data

Input		
Configurable/programmable	Yes, preconfigured	
Voltage input signal	0 V ... 10 V 1 V ... 5 V	
Max. voltage input signal	30 V	
Current input signal	0 mA ... 20 mA 4 mA ... 20 mA	
Max. current input signal	50 mA	
Input resistance of voltage input	Approx. 100 k Ω	
Input resistance current input	Approx. 50 Ω	
Output		
Non-load voltage	9 V	
Current output signal	2x 0 mA ... 20 mA 2x 4 mA ... 20 mA	
Max. current output signal	Approx. 22 mA	
Configurable/programmable	Yes, preconfigured	
Ripple	< 20 mV _{PP} (at 250 Ω)	
Load/output load current output	\leq 250 Ω (at 20 mA)	
Supply		
Nominal supply voltage	24 V DC	
Supply voltage range	19.2 V DC ... 30 V DC (to bridge the supply voltage, the DIN rail connector (ME 6,2 TBUS-2 1,5/5-ST-3,81 GN, Order No. 2869728) can be used. It can be snapped onto a 35 mm DIN rail according to EN 60715)	
Max. current consumption	< 30 mA (at 24 V DC incl. load)	
Power consumption	< 600 mW	
General data		
Limit frequency (3 dB)	Approx. 35 Hz	
Transmission error, typical	< 0.1 %	
Maximum transmission error	\leq 0.2 % (of final value)	
Temperature coefficient, typical	< 0.004 %/K	
Maximum temperature coefficient	< 0.01 %/K	
Step response (0–99%)	Approx. 10 ms	
Electrical isolation	Basic insulation according to EN 61010	
Surge voltage category	II	
Mounting position	Any	
Degree of protection	IP20	
Pollution degree	2	
Rated insulation voltage	50 V AC/DC	
Test voltage, input/output/supply	1.5 kV (50 Hz, 1 min.)	
Dimensions W / H / D	6.2 mm / 93.1 mm / 102.5 mm	
Type of housing	PBT green	
Connection data		
	Screw connection	Spring-cage conn.
Conductor cross section, solid	0.2 mm ² ... 2.5 mm ²	0.2 mm ² ... 2.5 mm ²
Conductor cross section, stranded	0.2 mm ² ... 2.5 mm ²	0.2 mm ² ... 2.5 mm ²
Stripping length	12 mm	8 mm

Ambient conditions

Ambient temperature (operation)	-20 °C ... 60 °C
Ambient temperature (storage/transport)	-40 °C ... 85 °C
Permissible humidity (operation)	10 % ... 95 % (no condensation)

Conformance with EMC Directive 2004/108/EC

Noise immunity according to EN 61000-6-2
Noise emission according to EN 61000-6-4

Conformance / approvals

Conformance	CE-compliant
ATEX	Ⓜ II 3 G Ex nA IIC T4 Gc X
UL, USA / Canada	UL 508 Recognized
UL, USA / Canada	Class I, Div. 2, Groups A, B, C, D T5
Shipbuilding	GL EMC 2 D

5 Safety regulations and installation notes

5.1 Installation notes

- The category 3 device is suitable for installation in the zone 2 potentially explosive area. It fulfills the requirements of EN 60079-0:2009 and EN 60079-15:2010.
- Installation, operation, and maintenance may only be carried out by qualified electricians. Follow the installation instructions described. When installing and operating the device, the applicable regulations and safety directives (including national safety directives), as well as general technical regulations, must be observed. The technical data is provided in this package slip and on the certificates (conformity assessment, additional approvals where applicable).
- It is not permissible to open or modify the device. Do not repair the device yourself but replace it with an equivalent device. Repairs may only be carried out by the manufacturer. The manufacturer is not liable for damage resulting from violation.
- The IP20 degree of protection (IEC 60529/EN 60529) of the device is intended for use in a clean and dry environment. Do not subject the device to any load that exceeds the described limits.
- The device is not designed for use in atmospheres with a danger of dust explosions.

5.2 Installation in the Ex area (zone 2)

- Observe the specified conditions for use in potentially explosive areas.
- The device must be installed in a housing (control or distributor box) which meets the requirements of EN 60079-15 and provides at least IP54 (EN 60529) degree of protection.
- During installation and when connecting the supply and signal circuits, observe the requirements of EN 60079-14. Devices may only be connected to circuits in zone 2 if they are suitable for operation in Ex zone 2 and for the prevailing conditions at the place of use.
- In potentially explosive areas, terminals may only be snapped onto or off the DIN rail connector and wires may only be connected or disconnected when the power is switched off.
- The device must be stopped and immediately removed from the Ex area if it is damaged, has been subjected to an impermissible load, has been stored incorrectly, or if it malfunctions.
- You can download the latest documents for these devices from www.phoenixcontact.net/catalog.

6 Installation

6.1 Connection notes



Attention: Electrostatic discharge!

The device contains components that can be damaged or destroyed by electrostatic discharge. When handling the device, observe the necessary safety precautions against electrostatic discharge (ESD) according to EN 61340-5-1 and EN 61340-5-2.

6.2 Structure

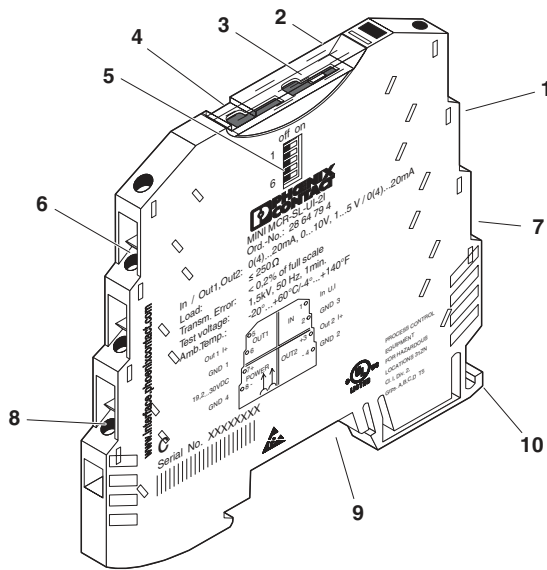

Figure 1 Structure

1. Input: Standard signals
2. Cover
3. Red LED
4. Groove for ZBF 6 zack marker strip
5. DIP switch S1
6. Output 1: Current signals
7. Output 2: Current signals
8. Supply voltage
9. Connection option for DIN rail bus connector
10. Universal snap-on foot for EN DIN rails

6.3 Block diagram

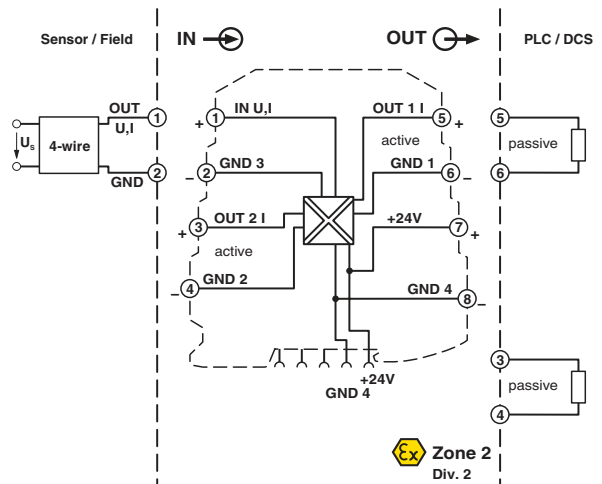

Figure 2 Block diagram

6.4 Power supply



ATTENTION:

Never connect the supply voltage directly to the DIN rail connector. It is not permitted to draw power from the DIN rail connector or from individual modules.

Supply via the module

Where the total current consumption of the aligned modules does not exceed 400 mA, the power can be supplied directly at the connection terminal blocks of the module.

A 400 mA fuse should be connected upstream.

Supply via a power terminal block

The MINI MCR-SL-PTB power terminal block (Order No. 2864134) or the MINI MCR-SL-PTB-SP power terminal block (Order No. 2864147), which are the same shape, are used to feed the supply voltage to the DIN rail connector.

A 2 A fuse should be connected upstream.

Supply via a system power supply unit

The system power supply unit with 1.5 A output current connects the DIN rail connector to the supply voltage and can therefore be used to supply several modules from the mains.

- MINI-SYS-PS-100-240AC/24DC/1.5 (Order No. 2866983)
- Potentially explosive areas:
MINI-PS-100-240AC/24DC/1.5/EX (Order No. 2866653)

6.5 Assembly

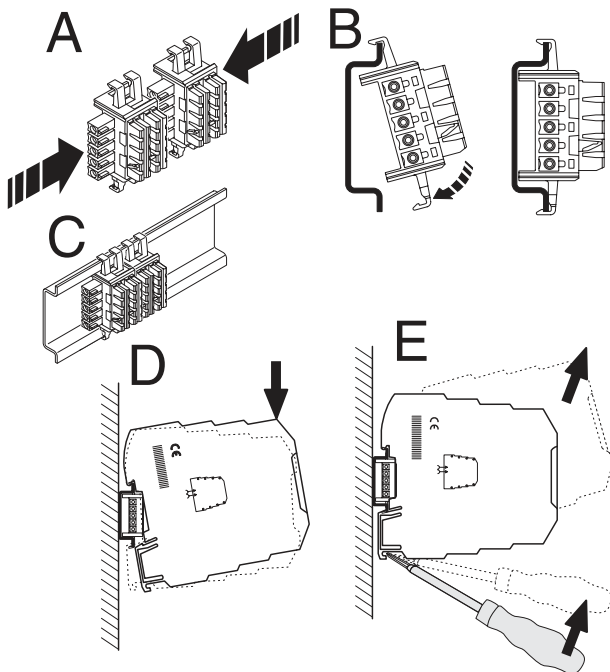

Figure 3 Mounting and removing

- Mount the module on a 35 mm DIN rail according to EN 60715.
- When using the DIN rail connector, first place it into the DIN rail (see A – C). It is used to bridge the power supply. It is also absolutely vital that you snap the module and the DIN rail connector into position in the correct direction: the snap-on foot should be at the bottom and the connector on the left.

6.6 Connecting the wires

The MINI MCR-SL-UI-2I... is available with two types of connection:

- Screw terminal blocks (MINI MCR-SL-UI-2I)
- Spring-cage terminal blocks (MINI MCR-SL-UI-2I-SP)

Screw connection:

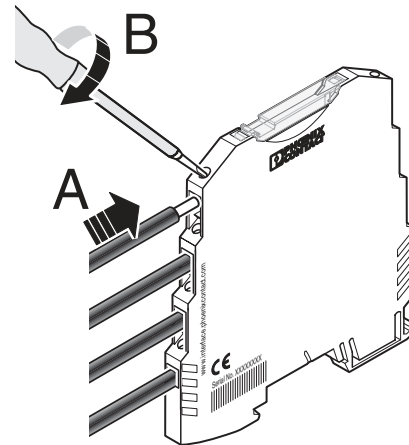

Figure 4 Screw connection

- Insert the wire into the corresponding connection terminal block.
- Use a screwdriver to tighten the screw in the opening above the connection terminal block.

Spring-cage connection:

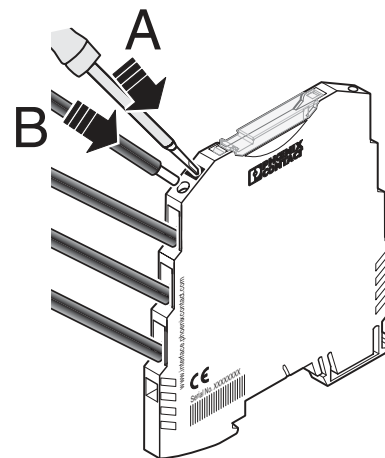

Figure 5 Spring-cage connection

- Insert a screwdriver into the opening above the connection terminal block.
- Insert the wire into the corresponding connection terminal block.

7 Configuration

DIP switch S1 is used to specify the combination of input and output standard signal ranges (see "Configuration table").

Standard Configuration

If it is an "NC version" (MINI MCR-SL-UI-2I-NC or MINI MCR-SL-UI-2I-SP-NC), the device will have the following standard configuration:

- 0 ... 10 V input
- Output (1 and 2) 0...20 mA

(All DIP switches are set to the "off" position.)

Configuration table

Input IN	DIP S1		
	1	2	3
0 ... 10 V	off	off	off
1 ... 5 V	off	ON	off
0 ... 20 mA	ON	off	ON
4 ... 20 mA	ON	ON	ON

Output	DIP S1 4
Analog behavior	off
Limitation	ON

Output OUT 1	Output OUT 2	DIP S1	
		5	6
0 ... 20 mA	0 ... 20 mA	off	off
0 ... 20 mA	4 ... 20 mA	ON	off
4 ... 20 mA	4 ... 20 mA	off	ON
Internal	Internal	ON	ON

8 Diagnostics LED

A red LED that signals overrange and underrange is located underneath the cover.



In the event of a fault in the parameter memory, the LED will flash. In this case, the device should be checked in the factory.

9 Limiting behavior of the analog outputs

The behavior of the output is set via the DIP switches. Limiting or analog behavior can be selected.

Explanation of the output combination:

	Output 1	Output 2
A	0 ... 20 mA	0 ... 20 mA
B	0 ... 20 mA	4 ... 20 mA
C	4 ... 20 mA	4 ... 20 mA

Behavior of the analog outputs

Configuration example, input 1...5 V DC, output 4...20 mA

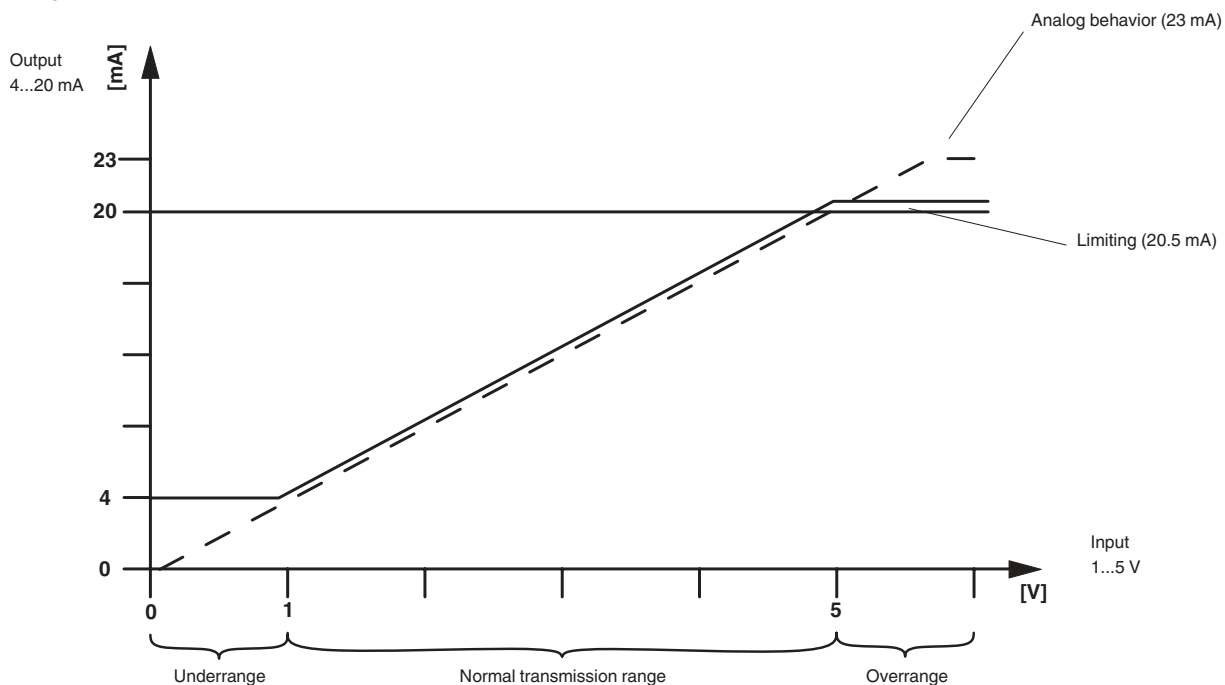

Figure 6 Behavior of the analog outputs