

THIS DRAWING IS UNPUBLISHED. RELEASED FOR PUBLICATION
 © COPYRIGHT - By - ALL RIGHTS RESERVED.

REVISIONS					
P	LTR	DESCRIPTION	DATE	DWN	APVD
F1		REVISED PER ECO-11-012152	16JUN11	HMR	DR
F2		REVISED PER ECO-17-008806	16FEB2018	RS	DR

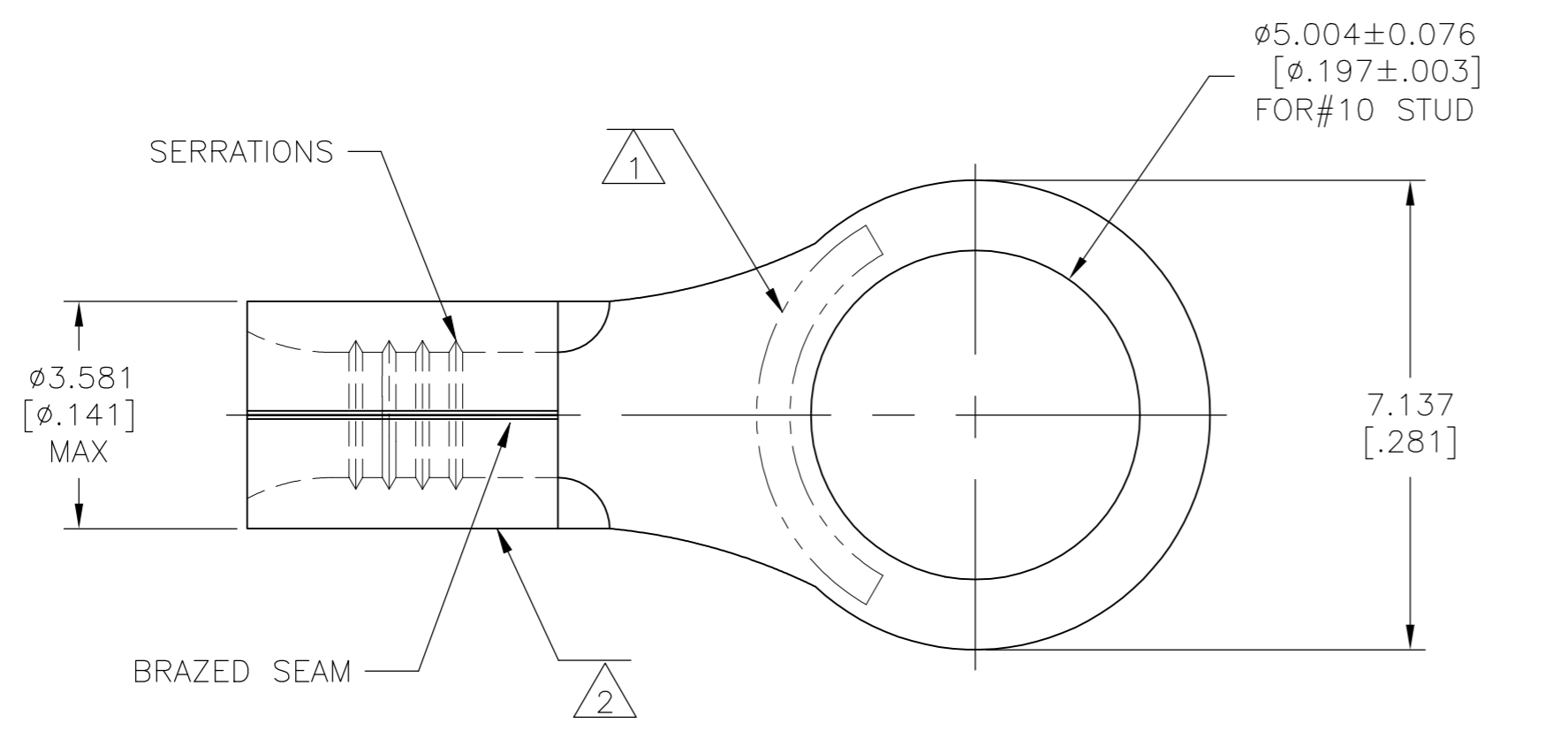

AMP
 WIRE RANGE
 22-16 AWG
 SOLID OR STRANDED

- 1 STAMP AMP 22-18 APPROX AS SHOWN
 22-16 TERMINALS ARE STAMPED 22-18 IN ACCORDANCE WITH MILITARY SPECIFICATION SAE AS7928 COMMERCIAL WIRE RANGE IS 22-16
- 2 WIRE BARREL COLOR CODED ORANGE TO DENOTE NICKEL MATERIAL
- 3 NOTE DELETED
- 4 NOTE DELETED

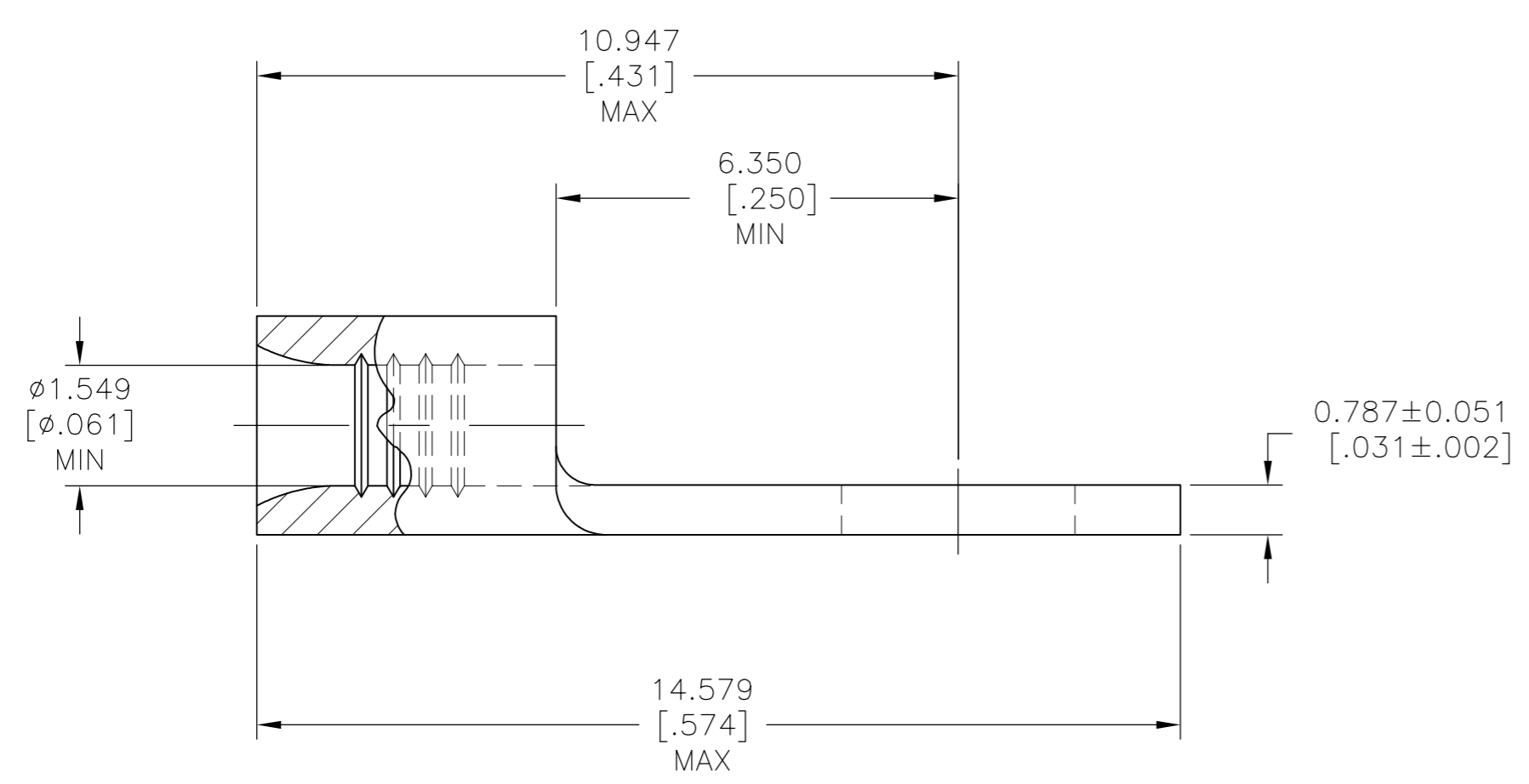

AMP INCORPORATED CUSTOMER SERVICE SYSTEMS		MAX RECOMMENDED OPERATING TEMPERATURE: SEE TABLE
FOR ADDITIONAL PRODUCT INFORMATION OR COPIES OF DRAWINGS AND TECHNICAL DOCUMENTS	PRODUCT INFORMATION CENTER 1-800-522-6752	VOLTAGE RATING: NOT APPLICABLE
FOR APPLICATION TOOLING INFORMATION	TOOLING ASSISTANCE CENTER 1-800-722-1111	WIRE CROSS SECTIONAL AREA RANGE: 0.26-1.65mm ² [509-3,260] CIR MILS SOLID OR STRANDED
FOR ORDER ENTRY	1-800-526-5142	THIS DRAWING IS A CONTROLLED DOCUMENT FOR AMP INCORPORATED. IT IS SUBJECT TO CHANGE AND THE CONTROLLING ENGINEERING ORGANIZATION SHOULD BE CONTACTED FOR THE LATEST REVISION.

2	-	649°C [1200°F]	100	LOOSE PIECE, BOX	8-321891-1
2	-	649°C [1200°F]	1000	LOOSE PIECE	321891
	FINISH	MAX OPERATING TEMP	QTY	PACKAGE TYPE	PART NO

THIS DRAWING IS A CONTROLLED DOCUMENT.		DWN TA BRINKMAN 4-15-93	STE TE Connectivity Ltd.		
DIMENSIONS: mm [INCHES]		CHK DA PATTERSON 4-15-93	NAME		
TOLERANCES UNLESS OTHERWISE SPECIFIED: 0 PLC ± - 1 PLC ± - 2 PLC ± - 3 PLC ± 0.127[.005] 4 PLC ± - ANGLES ± -		APVD DE MILLER 4-15-93	PRODUCT SPEC		
MATERIAL NICKEL PER ASTM B-162 ANNEALED		FINISH SEE TABLE	APPLICATION SPEC		RESTRICTED TO
		WEIGHT	SIZE A2	CAGE CODE 00779	DRAWING NO 321891
		CUSTOMER DRAWING	SCALE 10:1	SHEET 1 of 1	REV F2