

## AUIPS1011(S)(R)

### INTELLIGENT POWER LOW SIDE SWITCH

#### Features

- Over temperature shutdown
- Over current shutdown
- Active clamp
- Low current & logic level input
- ESD protection
- Optimized Turn On/Off for EMI
- Diagnostic on the input current

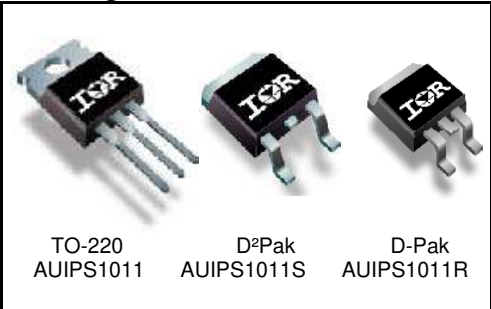
#### Description

The AUIPS1011(S)(R) is a three terminal Intelligent Power Switch (IPS) that features a low side MOSFET with over-current, over-temperature, ESD protection and drain to source active clamp. This device offers protections and the high reliability required in harsh environments. The switch provides efficient protection by turning OFF the power MOSFET when the temperature exceeds 165°C or when the drain current reaches 85A. The device restarts once the input is cycled. A serial resistance connected to the input provides the diagnostic. The avalanche capability is significantly enhanced by the active clamp and covers most inductive load demagnetizations.

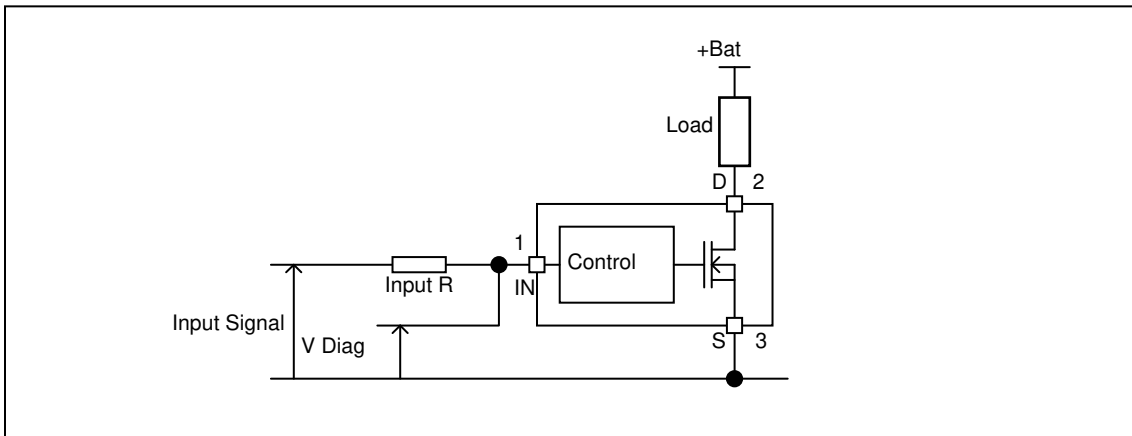
#### Product Summary

Rds(on)	13mΩ (max.)
Vclamp	39V
Ishutdown	85A (typ.)

#### Packages



#### Typical Connection



## Qualification Information<sup>†</sup>

<b>Qualification Level</b>		Automotive (per AEC-Q100 <sup>††</sup> )	
		Comments: This family of ICs has passed an Automotive qualification. IR's Industrial and Consumer qualification level is granted by extension of the higher Automotive level.	
<b>Moisture Sensitivity Level</b>		DPAK-3L	MSL1, 260°C (per IPC/JEDEC J-STD-020)
		D2PAK-3L	MSL1, 260°C (per IPC/JEDEC J-STD-020)
		TO220-5L	Not applicable
<b>ESD</b>	Machine Model	Class M4 (+/-450V) (per AEC-Q100-003)	
	Human Body Model	Class H2 (+/-2500V) (per AEC-Q100-002)	
	Charged Device Model	Class C4 (+/-1000V) (per AEC-Q100-011)	
<b>IC Latch-Up Test</b>		Class II, Level A (per AEC-Q100-004)	
<b>RoHS Compliant</b>		Yes	

† Qualification standards can be found at International Rectifier's web site <http://www.irf.com/>

†† Exceptions to AEC-Q100 requirements are noted in the qualification report.

## Absolute Maximum Ratings

Absolute maximum ratings indicate sustained limits beyond which damage to the device may occur. (T<sub>j</sub>= -40°C..150°C, V<sub>cc</sub>=6..36V unless otherwise specified).

Symbol	Parameter	Min.	Max.	Units
V <sub>ds</sub>	Maximum drain to source voltage	-0.3	36	V
V <sub>ds cont.</sub>	Maximum continuous drain to source voltage	-	28	V
V <sub>in</sub>	Maximum input voltage	-0.3	6	V
I <sub>sd cont.</sub>	Max diode continuous current (limited by thermal dissipation)	—	5	A
P <sub>d</sub>	Maximum power dissipation (internally limited by thermal protection)			
	R <sub>th</sub> =5°C/W AUIPS1011	—	25	W
	R <sub>th</sub> =40°C/W AUIPS1011S 1" sqr. footprint	—	3.1	
R <sub>th</sub> =50°C/W AUIPS1011R 1" sqr. footprint	—	2.5		
T <sub>j max.</sub>	Max. storage & operating temperature junction temperature	-40	150	°C

## Thermal Characteristics

Symbol	Parameter	Typ.	Max.	Units
R <sub>th1</sub>	Thermal resistance junction to ambient AUIPS1011 TO-220 free air	50	—	°C/W
R <sub>th2</sub>	Thermal resistance junction to case AUIPS1011 TO-220	1.2	—	
R <sub>th1</sub>	Thermal resistance junction to ambient AUIPS1011S D <sup>2</sup> Pak std. footprint	60	—	
R <sub>th2</sub>	Thermal resistance junction to ambient AUIPS1011S D <sup>2</sup> Pak 1" sqr. footprint	40	—	
R <sub>th3</sub>	Thermal resistance junction to case AUIPS1011S D <sup>2</sup> Pak	1.2	—	
R <sub>th1</sub>	Thermal resistance junction to ambient AUIPS1011R D-Pak std. footprint	70	—	
R <sub>th2</sub>	Thermal resistance junction to ambient AUIPS1011R D-Pak 1" sqr. footprint	50	—	
R <sub>th3</sub>	Thermal resistance junction to case AUIPS1011R D-Pak	1.2	—	

## Recommended Operating Conditions

These values are given for a quick design. For operation outside these conditions, please consult the application notes.

Symbol	Parameter	Min.	Max.	Units
V <sub>IH</sub>	High level input voltage	4.5	5.5	
V <sub>IL</sub>	Low level input voltage	0	0.5	
I <sub>ds</sub>	Continuous drain current, T <sub>ambient</sub> =85°C, T <sub>j</sub> =125°C, V <sub>in</sub> =5V			A
	R <sub>th</sub> =5°C/W AUIPS1011	—	18	
	R <sub>th</sub> =40°C/W AUIPS1011S 1" sqr. Footprint	—	6.5	
	R <sub>th</sub> =50°C/W AUIPS1011R 1" sqr. Footprint	—	6	
R <sub>in</sub>	Recommended resistor in series with IN pin to generate a diagnostic	0.5	10	kΩ
Max L	Max recommended load inductance (including line inductance) (1)	—	5	μH
Max F	Max frequency (switching losses = conduction losses)	—	200	Hz
Max t rise	Max Input rising time	—	1	μs

(1) Higher inductance is possible if maximum load current is limited - see figure 11

## Static Electrical Characteristics

$T_j = -40..150^{\circ}\text{C}$ ,  $V_{cc}=6..28\text{V}$  (unless otherwise specified), typical value are given for  $T_j=25^{\circ}\text{C}$

Symbol	Parameter	Min.	Typ.	Max.	Units	Test Conditions
Rds(on)	ON state resistance $T_j=25^{\circ}\text{C}$	—	10	13	m $\Omega$	$V_{in}=5\text{V}$ , $I_{ds}=30\text{A}$
	ON state resistance $T_j=150^{\circ}\text{C}$ (2)	—	19	25		
Idss1	Drain to source leakage current	—	0.1	2	$\mu\text{A}$	$V_{cc}=14\text{V}$ , $T_j=25^{\circ}\text{C}$
Idss2	Drain to source leakage current	—	0.2	4		$V_{cc}=28\text{V}$ , $T_j=25^{\circ}\text{C}$
V clamp1	Drain to source clamp voltage 1	36	39	—	V	$I_d=20\text{mA}$
V clamp2	Drain to source clamp voltage 2	—	39	42		$I_d=5\text{A}$
Vin clamp	IN to source pin clamp voltage	5.5	6.5	7.5		$I_{in}=1\text{mA}$
Vth	Input threshold voltage	—	1.7	—		$I_d=10\text{mA}$

## Switching Electrical Characteristics

$V_{cc}=14\text{V}$ , Resistive load=0.5 $\Omega$ ,  $R_{input}=50\Omega$ ,  $V_{in}=5\text{V}$ ,  $T_j=25^{\circ}\text{C}$

Symbol	Parameter	Min.	Typ.	Max.	Units	Test Conditions
Tdon	Turn-on delay time to 20%	15	50	150	$\mu\text{s}$	See figure 2
Tr	Rise time 20% to 80%	20	50	100		
Tdoff	Turn-off delay time to 80%	100	330	700		
Tf	Fall time 80% to 20%	30	70	150		
Eon + Eoff	Turn on and off energy	—	5	—	mJ	

## Protection Characteristics

$T_j = -40..150^{\circ}\text{C}$ ,  $V_{cc}=6..28\text{V}$  (unless otherwise specified), typical value are given for  $T_j=25^{\circ}\text{C}$

Symbol	Parameter	Min.	Typ.	Max.	Units	Test Conditions
Tsd	Over temperature threshold	150(2)	165	—	$^{\circ}\text{C}$	See figure 1
Isd	Over current threshold	44	85	120	A	See figure 1
OV	Over voltage protection (not active when the device is ON)	34	37	—	V	
Vreset	IN protection reset threshold	—	1.7	—	V	
Treset	Time to reset protection	15(2)	50	200	$\mu\text{s}$	$V_{in}=0\text{V}$

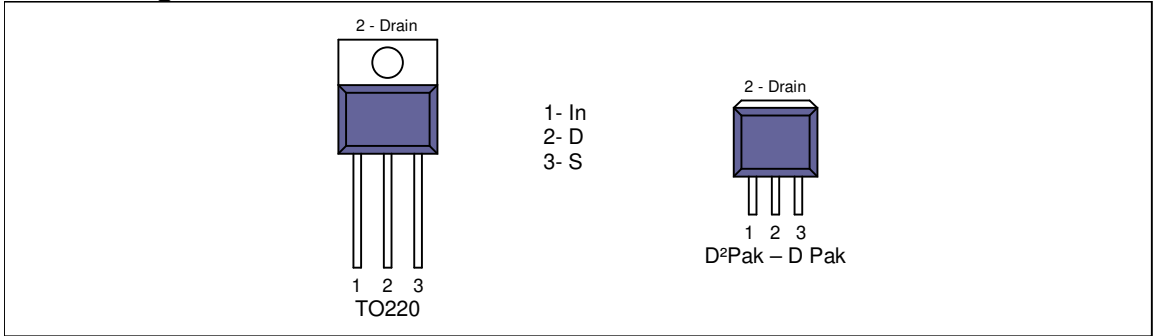
## Diagnostic

$T_j = -40..150^{\circ}\text{C}$ ,  $V_{cc}=6..28\text{V}$  (unless otherwise specified), typical value are given for  $T_j=25^{\circ}\text{C}$

Symbol	Parameter	Min.	Typ.	Max.	Units	Test Conditions
Iin, on	ON state IN positive current	15	32	70	$\mu\text{A}$	$V_{in}=5\text{V}$
Iin, off	OFF state IN positive current (after protection latched)	150	230	350		$V_{in}=5\text{V}$

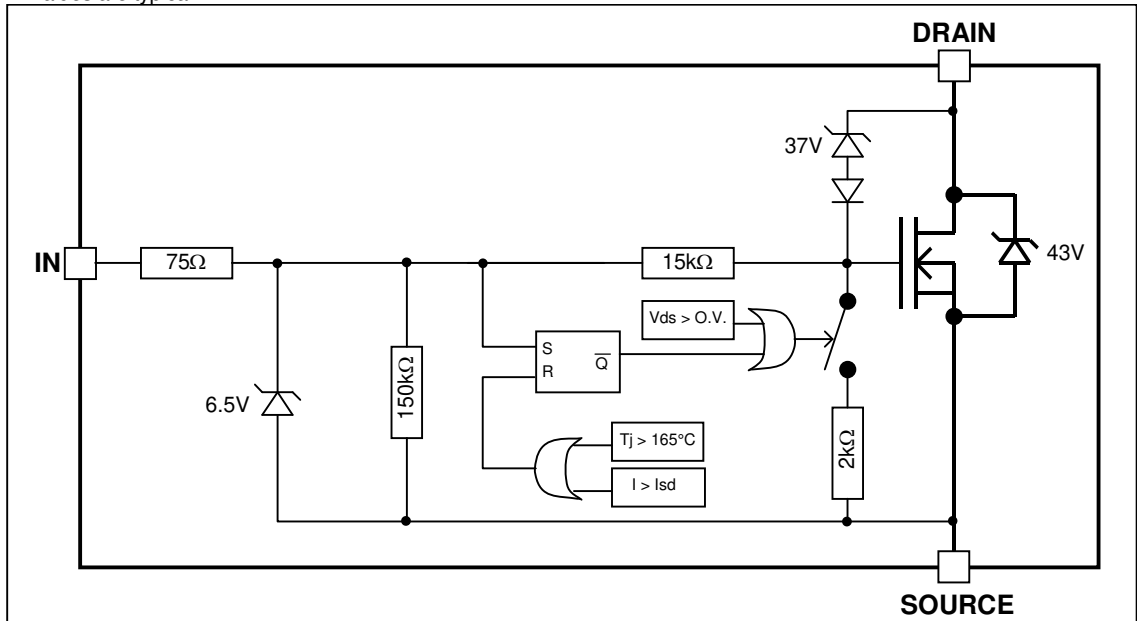
(2) Guaranteed by design

## Lead Assignments

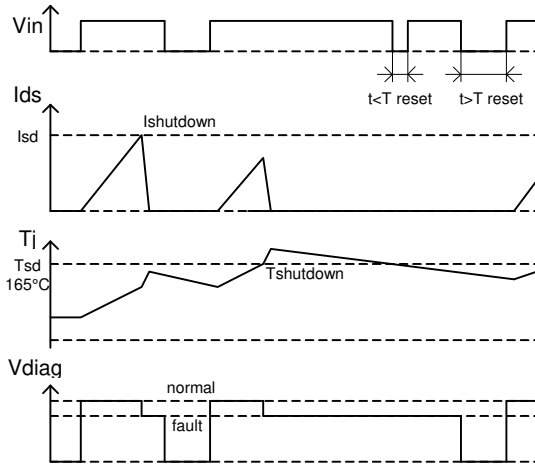


## Functional Block Diagram

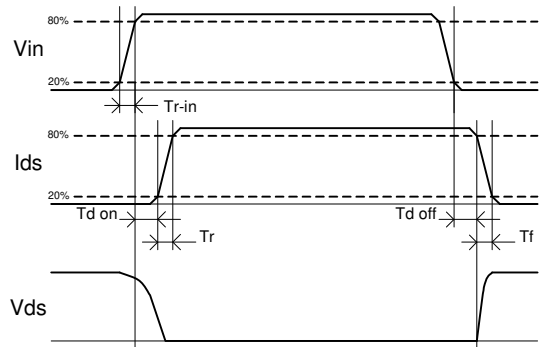
All values are typical



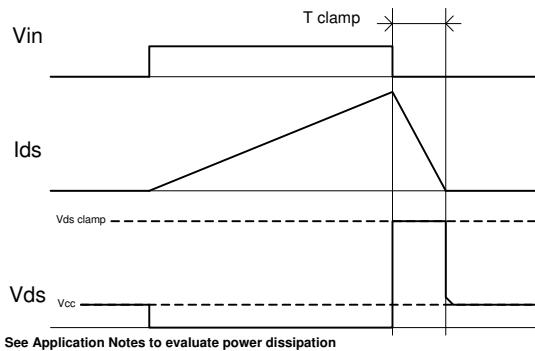
All curves are typical values. Operating in the shaded area is not recommended.



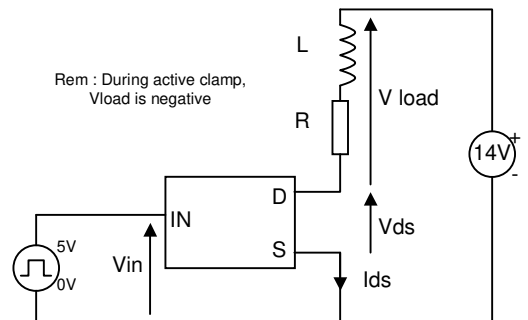
**Figure 1 – Timing diagram**



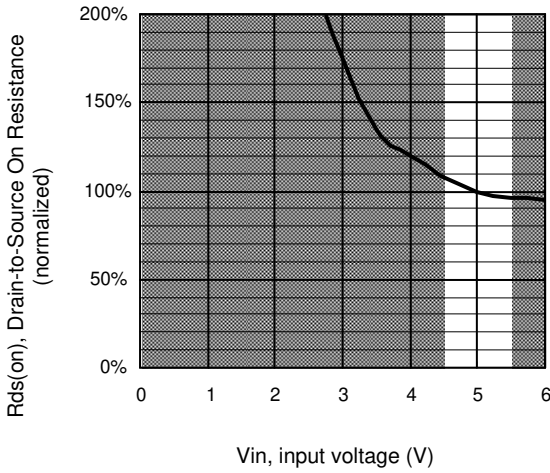
**Figure 2 – IN rise time & switching definitions**



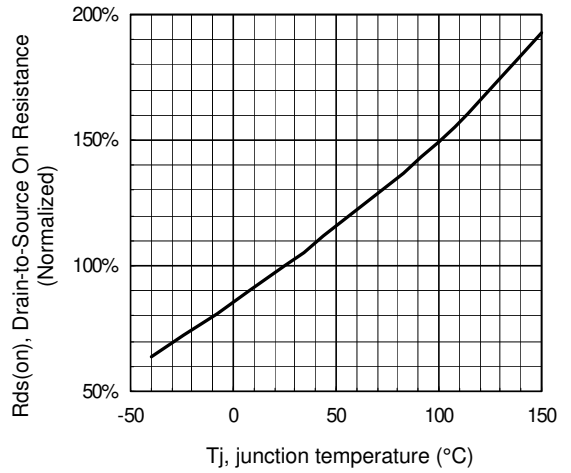
**Figure 3 – Active clamp waveforms**



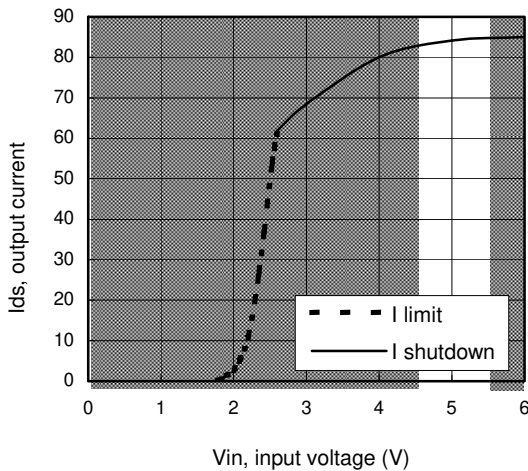
**Figure 4 – Active clamp test circuit**



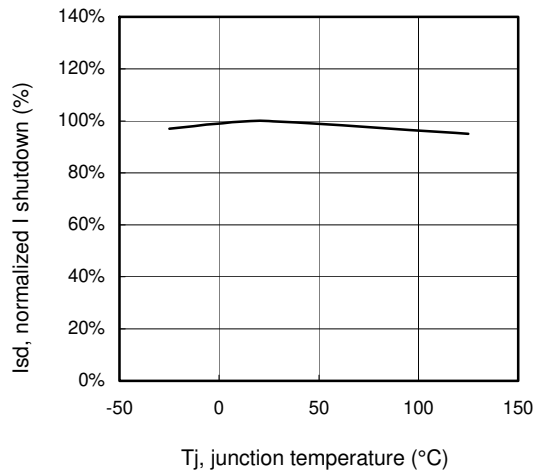
**Figure 5 – Normalized Rds(on) (%) Vs Input voltage (V)**



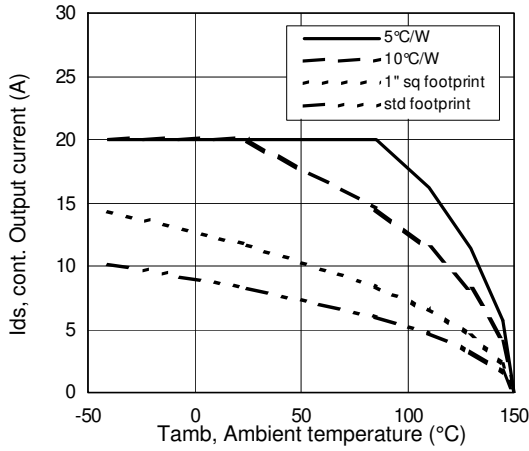
**Figure 6 - Normalized Rds(on) (%) Vs T<sub>j</sub> (°C)**



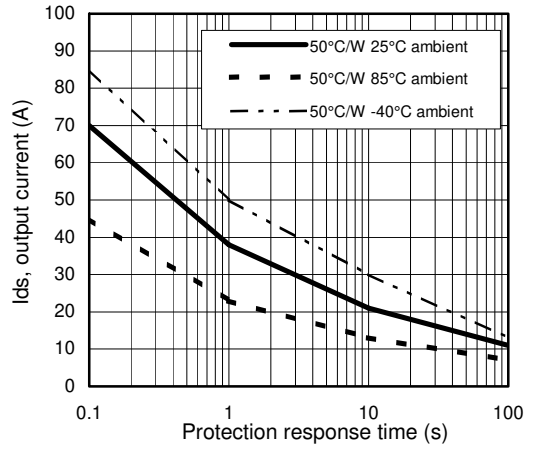
**Figure 7 – Current limitation and current shutdown Vs Input voltage (V)**



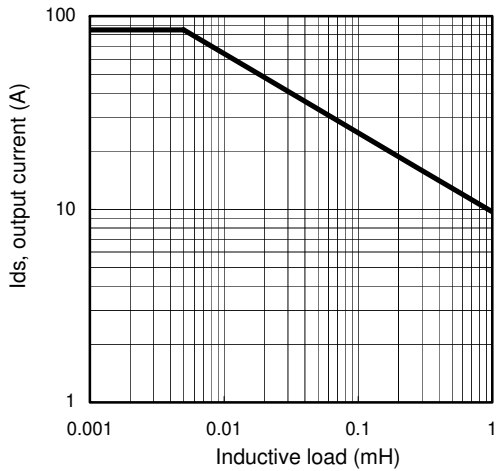
**Figure 8 – Normalized I shutdown (%) Vs junction temperature (°C)**



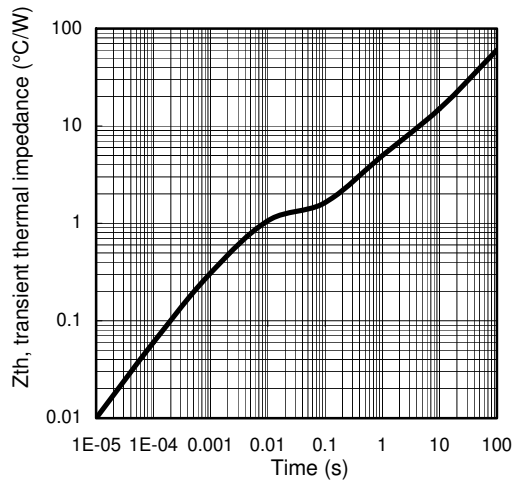
**Figure 9 – Max. continuous output current (A) Vs Ambient temperature (°C)**



**Figure 10 –  $I_{ds}$  (A) Vs over temperature protection response time (s)**

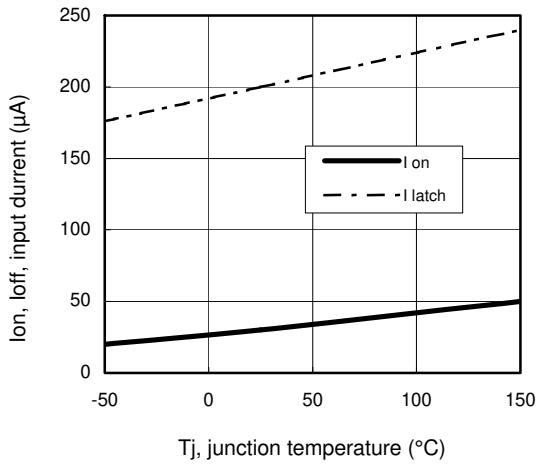


**Figure 11 – Max. output current (A) Vs Inductive load (mH)**

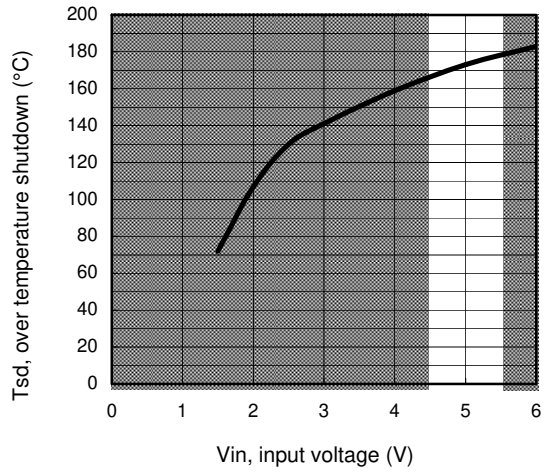


**Figure 12 – Transient thermal impedance (°C/W) Vs time (s)**



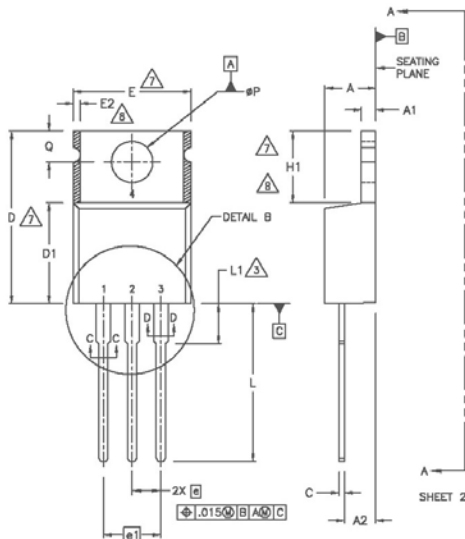
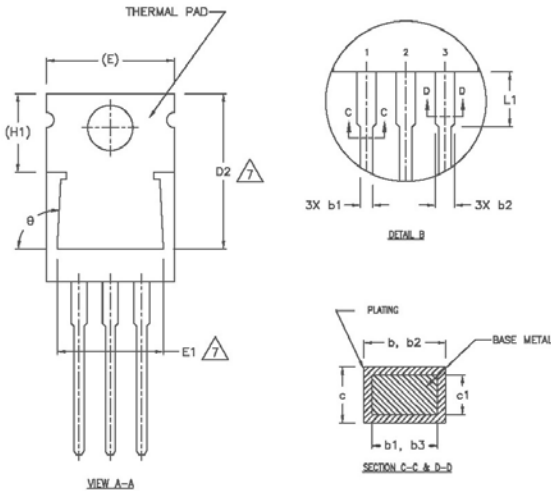


**Figure 13 – Input current (µA) On and Off Vs junction temperature (°C)**



**Figure 14 – Over temperature shutdown (°C) Vs input voltage (V)**

## Case Outline – TO-220 AB – Automotive Q100 PbF qualified

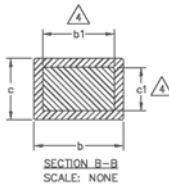
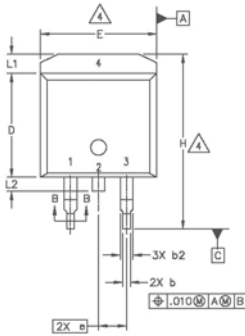
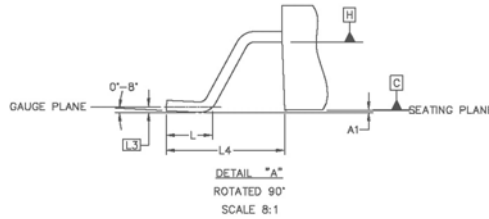
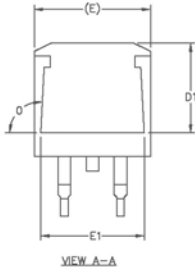


SYMBOL	DIMENSIONS				NOTES
	MILLIMETERS		INCHES		
	MIN.	MAX.	MIN.	MAX.	
A	3.56	4.82	.140	.190	
A1	0.51	1.40	.020	.055	
A2	2.04	2.92	.080	.115	
b	0.38	1.01	.015	.040	
b1	0.38	0.96	.015	.038	5
b2	1.15	1.77	.045	.070	
b3	1.15	1.73	.045	.068	
c	0.36	0.61	.014	.024	
c1	0.36	0.56	.014	.022	5
D	14.22	16.51	.560	.650	4
D1	8.38	9.02	.330	.355	
D2	12.19	12.88	.480	.507	7
E	9.66	10.66	.380	.420	4,7
E1	8.38	8.89	.330	.350	7
e	2.54 BSC		.100 BSC		
e1	5.08		.200 BSC		
H1	5.85	6.55	.230	.270	7,8
L	12.70	14.73	.500	.580	
L1	—	6.35	—	.250	3
θP	3.54	4.08	.139	.161	
Q	2.54	3.42	.100	.135	
φ	90°-93°		90°-93°		

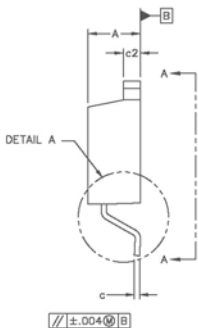
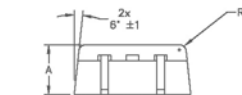
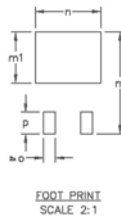
NOTES:

- 1 DIMENSIONING AND TOLERANCING PER ASME Y14.5 M- 1994.
- 2 DIMENSIONS ARE SHOWN IN INCHES [MILLIMETERS].
- 3 LEAD DIMENSION AND FINISH UNCONTROLLED IN L1.
- 4 DIMENSION D & E DO NOT INCLUDE MOLD FLASH. MOLD FLASH SHALL NOT EXCEED .005" (0.127) PER SIDE. THESE DIMENSIONS ARE MEASURED AT THE OUTERMOST EXTREMES OF THE PLASTIC BODY.
- 5 DIMENSION b1 & c1 APPLY TO BASE METAL ONLY.
- 6 CONTROLLING DIMENSION : INCHES.
- 7 THERMAL PAD CONTOUR OPTIONAL WITHIN DIMENSIONS E,H1,D2 & E1
- 8 DIMENSION E2 X H1 DEFINE A ZONE WHERE STAMPING AND SINGULATION IRREGULARITIES ARE ALLOWED.
- 9 LEADS AND DRAIN ARE PLATED WITH 100% Sn

## Case Outline - D<sup>2</sup>Pak (SMD-220) - Automotive Q100 PbF MSL1 qualified



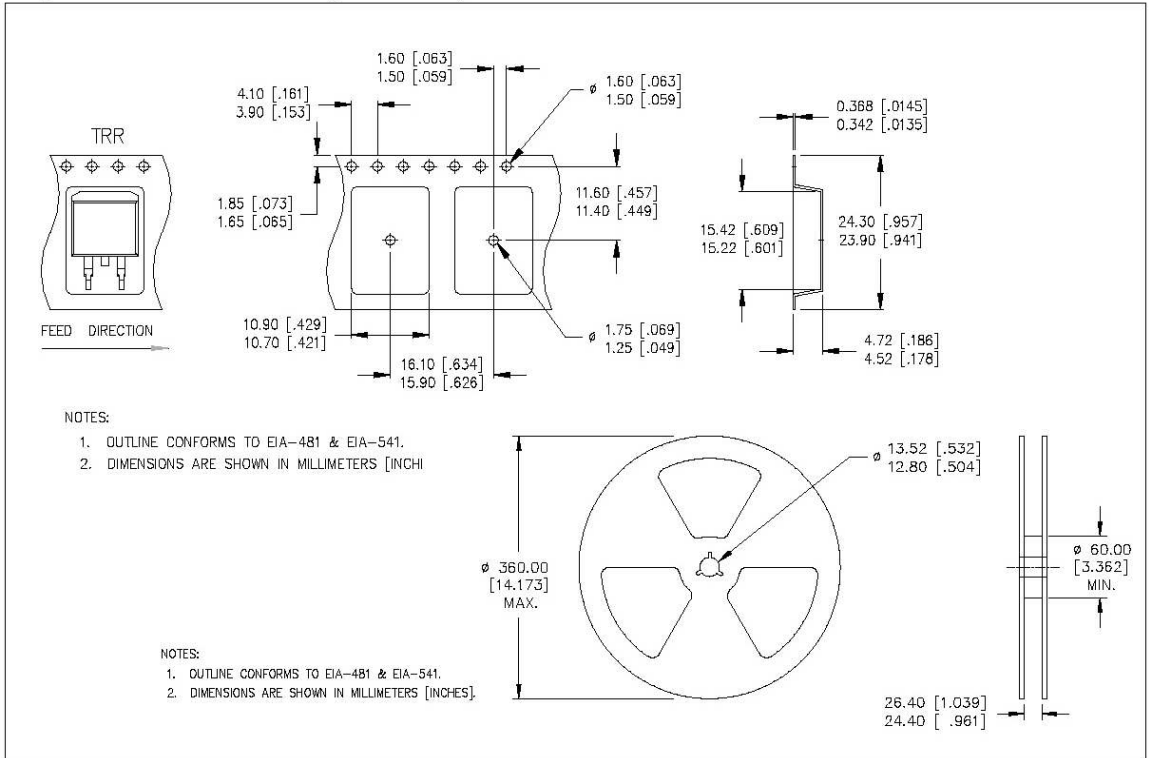
SYMBOL	DIMENSIONS				NOTES
	MILLIMETERS		INCHES		
	MIN.	MAX.	MIN.	MAX.	
A	4.06	4.83	.160	.190	
A1	0.00	0.254	.000	.010	
b	0.51	0.99	.020	.039	4
b1	0.51	0.89	.020	.035	
b2	1.14	1.78	.045	.070	
c	0.38	0.74	.015	.029	
c1	0.38	0.58	.015	.023	4
c2	1.14	1.65	.045	.065	
D	8.51	9.65	.335	.380	3
D1	8.86		.270		
E	9.65	10.67	.380	.420	3
E1	6.22		.245		
e	2.54 BSC		.100 BSC		
H	14.61	15.88	.575	.625	
L	1.78	2.79	.070	.110	
L1		1.65		.065	
L2	1.27	1.78	.050	.070	
L3	0.25 BSC		.010 BSC		
L4	4.78	5.28	.188	.208	
m	17.78		.700		
m1	8.89		.350		
n	11.43		.450		
o	2.08		.082		
p	3.81		.150		
R	0.51	0.71	.020	.028	
θ	90°	93°	90°	93°	



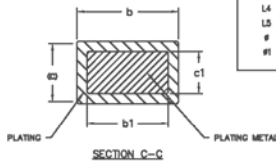
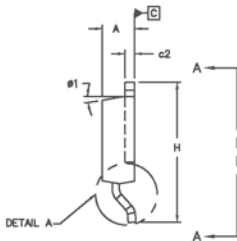
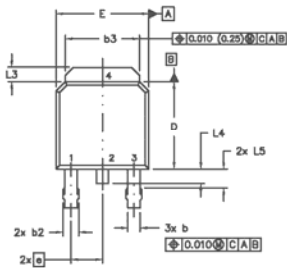
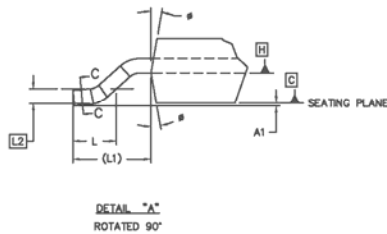
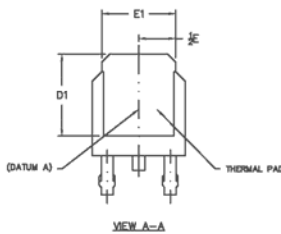
NOTES:

- DIMENSIONING AND TOLERANCING PER ASME Y14.5M-1994
- DIMENSIONS ARE SHOWN IN MILLIMETERS [INCHES]
- DIMENSION D & E DO NOT INCLUDE MOLD FLASH. MOLD FLASH SHALL NOT EXCEED 0.127 [0.005"] PER SIDE. THESE DIMENSIONS ARE MEASURED AT THE OUTMOST EXTREMES OF THE PLASTIC BODY.
- DIMENSION b1 AND c1 APPLY TO BASE METAL ONLY.
- CONTROLLING DIMENSION: INCH.
- LEADS & DRAIN CONTACT ARE PLATED : 100% Sn

## Tape & Reel - D<sup>2</sup>Pak (SMD220)



## Case Outline – D-Pak - Automotive Q100 PbF MSL1 qualified

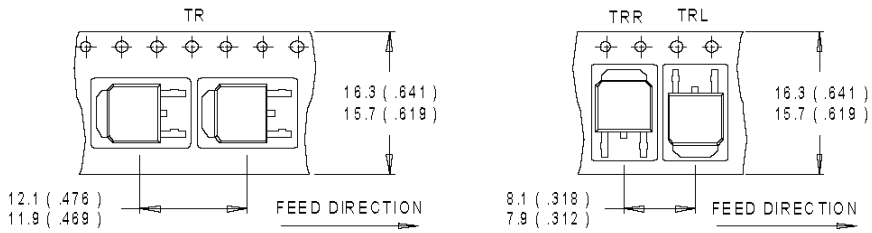


SYMBOL	DIMENSIONS				NOTES
	MILLIMETERS		INCHES		
	MIN.	MAX.	MIN.	MAX.	
A	2.18	2.30	.086	.094	
A1		0.13		.005	
b	0.84	0.89	.033	.035	5
b1	0.84	0.79	.033	0.031	5
b2	0.78	1.14	.030	.045	
b3	4.95	5.48	.195	.215	
c	0.48	0.61	.018	.024	5
c1	0.41	0.58	.016	.022	5
c2	.048	0.89	.018	.035	5
D	5.97	8.22	.235	.345	6
D1	5.21	-	.205	-	4
E	6.35	6.73	.250	.265	6
E1	4.32	-	.170	-	4
e	2.28		.090 BSC		
H	8.40	10.41	.330	.410	
L	1.40	1.75	.055	.070	
L1	2.74 REF.		.108 BSC		
L2	0.51 BSC		.020 BSC		
L3	0.89	1.27	.035	.050	
L4		1.02		.040	
L5	1.14	1.52	.045	.060	3
φ	0"	10"	0"	10"	
φ1	0"	15"	0"	15"	

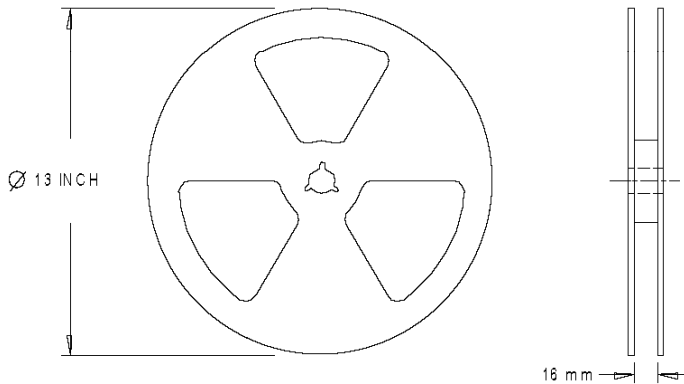
NOTES:

- 1.0 DIMENSIONING AND TOLERANCING PER ASME Y14.5 M- 1994.
- 2.0 DIMENSIONS ARE SHOWN IN INCHES [MILLIMETERS].
- 3.0 LEAD DIMENSION UNCONTROLLED IN L5
- 4.0 DIMENSION D1 AND E1 ESTABLISH A MINIMUM MOUNTING SURFACE FOR THERMAL PAD.
- 5.0 SECTION C-C DIMENSIONS APPLY TO THE FLAT SECTION OF THE LEAD BETWEEN .005 [0.127] AND .010 [0.2540 FROM THE LEAD TIP.
- 6.0 DIMENSION D & E DO NOT INCLUDE MOLD FLASH. MOLD FLASH SHALL NOT EXCEED .005" (0.127) PER SIDE. THESE DIMENSIONS ARE MEASURED AT THE OUTERMOST EXTREMES OF THE PLASTIC BODY.
- 7.0 OUTLINE CONFORMS TO JEDEC OUTLINE TO-252AA.
- 8.0 LEADS AND DRAIN ARE PLATED WITH 100% Sn

## Tape & Reel - D-Pak



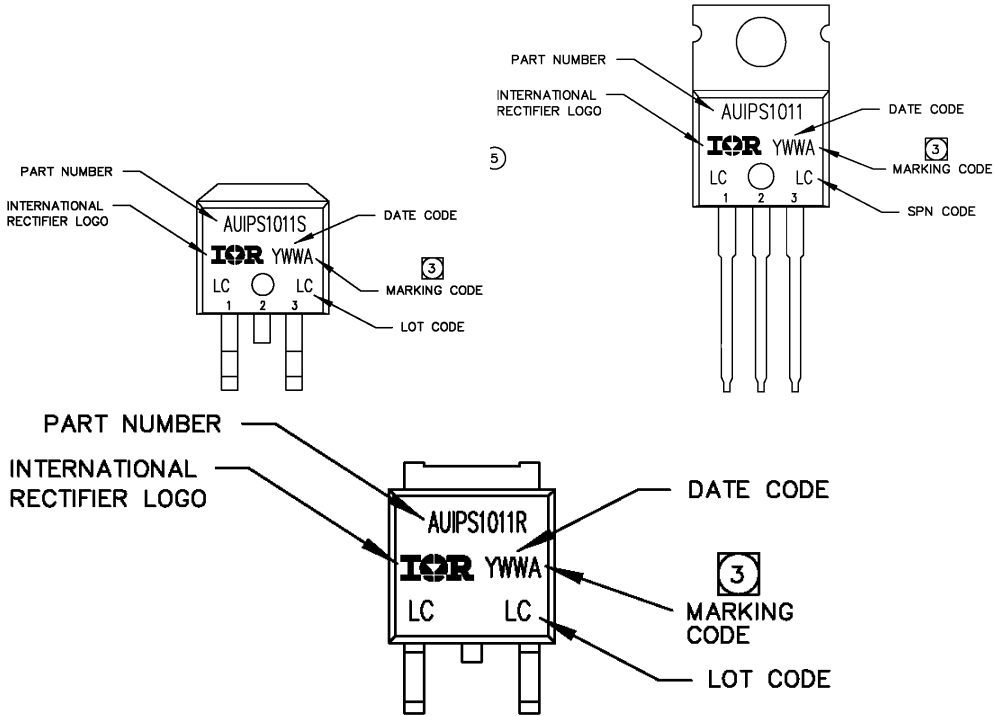
- NOTES :
1. CONTROLLING DIMENSION : MILLIMETER.
  2. ALL DIMENSIONS ARE SHOWN IN MILLIMETERS ( INCHES ).
  3. OUTLINE CONFORMS TO EIA-481 & EIA-541.



- NOTES :
1. OUTLINE CONFORMS TO EIA-481.

Dimensions are shown in millimeters (inches)

## Part Marking Information



## Ordering Information

Base Part Number	Package Type	Standard Pack		Complete Part Number	
		Form	Quantity		
AUIPS1011	TO220 – 5Leads	Tube	50	AUIPS1011	
		Tube	50	AUIPS1011S	
	D2-Pak-5-Leads	Tape and reel left	800	AUIPS1011STRL	
		Tape and reel right	800	AUIPS1011STRR	
		D-Pak-5-Lead	Tube	75	AUIPS1011R
			Tape and reel	2000	AUIPS1011RTR
	Tape and reel left		3000	AUIPS1011RTRL	
	Tape and reel right		3000	AUIPS1011RTRR	

## IMPORTANT NOTICE

Unless specifically designated for the automotive market, International Rectifier Corporation and its subsidiaries (IR) reserve the right to make corrections, modifications, enhancements, improvements, and other changes to its products and services at any time and to discontinue any product or services without notice. Part numbers designated with the "AU" prefix follow automotive industry and / or customer specific requirements with regards to product discontinuance and process change notification. All products are sold subject to IR's terms and conditions of sale supplied at the time of order acknowledgment.

IR warrants performance of its hardware products to the specifications applicable at the time of sale in accordance with IR's standard warranty. Testing and other quality control techniques are used to the extent IR deems necessary to support this warranty. Except where mandated by government requirements, testing of all parameters of each product is not necessarily performed.

IR assumes no liability for applications assistance or customer product design. Customers are responsible for their products and applications using IR components. To minimize the risks with customer products and applications, customers should provide adequate design and operating safeguards.

Reproduction of IR information in IR data books or data sheets is permissible only if reproduction is without alteration and is accompanied by all associated warranties, conditions, limitations, and notices. Reproduction of this information with alterations is an unfair and deceptive business practice. IR is not responsible or liable for such altered documentation. Information of third parties may be subject to additional restrictions.

Resale of IR products or serviced with statements different from or beyond the parameters stated by IR for that product or service voids all express and any implied warranties for the associated IR product or service and is an unfair and deceptive business practice. IR is not responsible or liable for any such statements.

IR products are not designed, intended, or authorized for use as components in systems intended for surgical implant into the body, or in other applications intended to support or sustain life, or in any other application in which the failure of the IR product could create a situation where personal injury or death may occur. Should Buyer purchase or use IR products for any such unintended or unauthorized application, Buyer shall indemnify and hold International Rectifier and its officers, employees, subsidiaries, affiliates, and distributors harmless against all claims, costs, damages, and expenses, and reasonable attorney fees arising out of, directly or indirectly, any claim of personal injury or death associated with such unintended or unauthorized use, even if such claim alleges that IR was negligent regarding the design or manufacture of the product.

IR products are neither designed nor intended for use in military/aerospace applications or environments unless the IR products are specifically designated by IR as military-grade or "enhanced plastic." Only products designated by IR as military-grade meet military specifications. Buyers acknowledge and agree that any such use of IR products which IR has not designated as military-grade is solely at the Buyer's risk, and that they are solely responsible for compliance with all legal and regulatory requirements in connection with such use.

IR products are neither designed nor intended for use in automotive applications or environments unless the specific IR products are designated by IR as compliant with ISO/TS 16949 requirements and bear a part number including the designation "AU". Buyers acknowledge and agree that, if they use any non-designated products in automotive applications, IR will not be responsible for any failure to meet such requirements.

For technical support, please contact IR's Technical Assistance Center  
<http://www.irf.com/technical-info/>

**WORLD HEADQUARTERS:**  
233 Kansas St., El Segundo, California 90245  
Tel: (310) 252-7105



**Revision History**

<b>Revision</b>	<b>Date</b>	<b>Notes/Changes</b>
C	November, 24 <sup>th</sup> , 2010	AU release
C1	December, 7 <sup>th</sup> 2010	Update ESD rating
C2	December, 9 <sup>th</sup> 2010	Update qual page 2
D	February, 8 <sup>th</sup> 2011	Update Vclamp page 1
E	February, 28 <sup>th</sup> 2011	Update max rating