

ISL81801DEMO1Z

Demonstration Board

The ISL81801DEMO1Z demonstration board (shown in [Figure 8](#)) features the [ISL81801](#), a 80V high voltage synchronous buck-boost controller that provides external soft-start, independent enable functions, and integrates UV/OV/OC/OT protection. Programmable switching frequency ranging from 100kHz to 600kHz helps to optimize the inductor size while the strong gate driver delivers up to 20A for the buck-boost output.

Key Features

- Wide input range: 32V to 80V
- Bidirectional operation
- High light-load efficiency in pulse skipping DEM operation
- Programmable soft-start
- Optional DEM/PWM operation
- Optional CC/HICCUP OCP protection
- Supports prebias output with soft-start
- PGOOD indicator
- OVP, OTP, and UVP protection
- Parallelable operation

Specifications

The ISL81801DEMO1Z demonstration board is designed for high current applications. The current rating of the ISL81801DEMO1Z is limited by the FETs and inductor selected. The ISL81801DEMO1Z electrical ratings are shown in [Table 1](#).

Table 1. Electrical Ratings

Parameter	Rating
Input Voltage	32V to 80V
Switching Frequency	200kHz
Output Voltage	48V
Output Current	10A
OCP Set Point	Minimum 11A at ambient room temperature

Ordering Information

Part Number	Description
ISL81801DEMO1Z	Parallelable high voltage buck-boost controller demonstration board

Related Literature

For a full list of related documents, visit our website:

- [ISL81801](#) product page

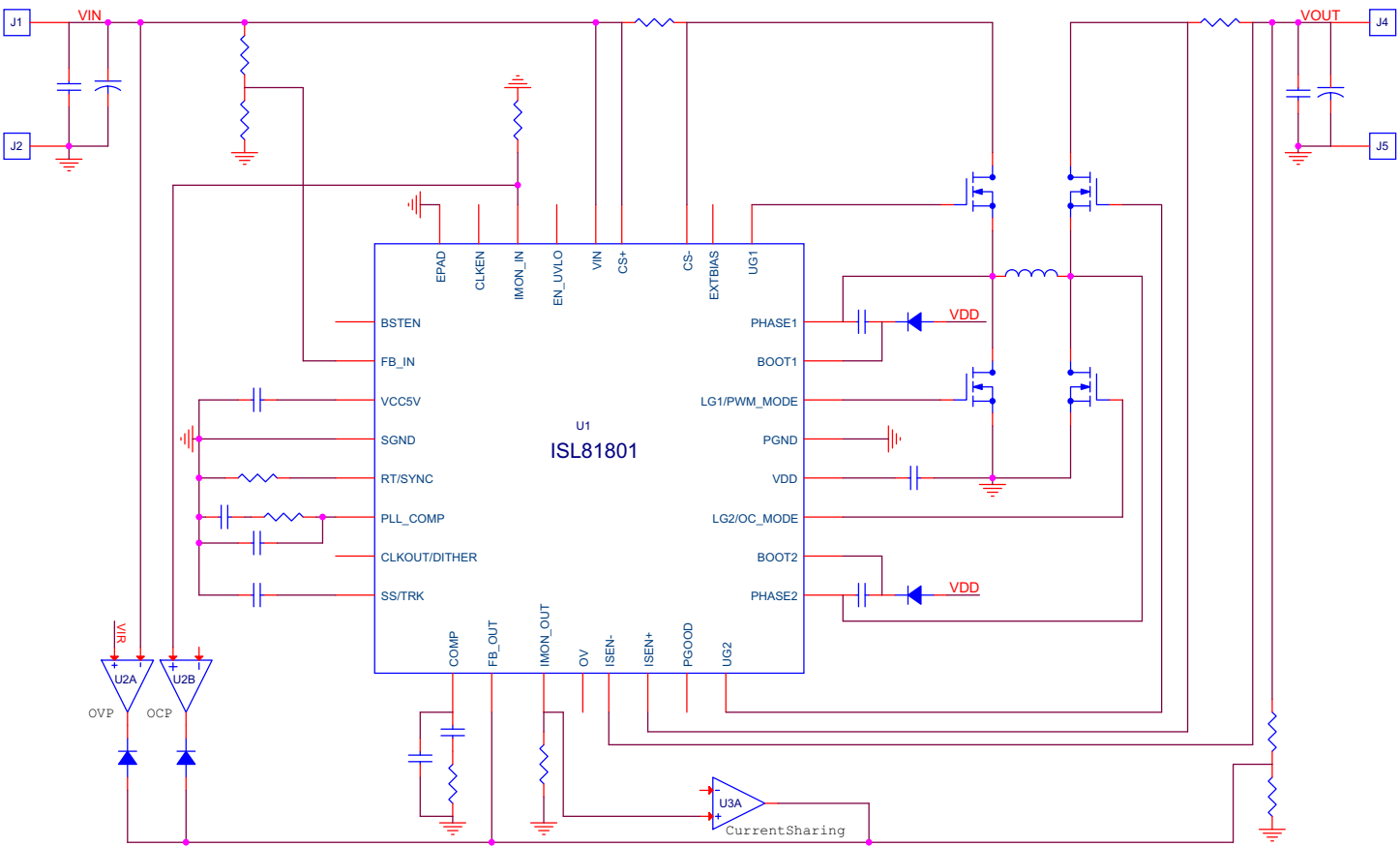

Figure 1. ISL81801DEMO1Z Block Diagram

1. Functional Description

The ISL81801DEMO1Z demonstrates the performance of the ISL81801 TQFN IC. The board provides an easy and complete demonstration of all the IC and board functions.

As shown in [Figure 7](#), 32V to 80V V_{IN} is supplied to J₁ (+) and J₂ (-). The regulated 48V output on J₄ (+) and J₅ (-) can supply up to 10A to the load. Because of the high power efficiency, the demonstration board can run at 5A continuously without airflow at room temperature ambient conditions.

Test points TP₁ through TP₂₈ provide easy access to the IC pin and external signal injection terminals.

As shown in [Figure 3](#), connector J₈ provides selection of either Forced PWM mode (shorting Pin 1 and Pin 2) or DEM mode (shorting Pin 2 and Pin 3). Connector J₉ provides selection of either constant current limit (shorting Pin 1 and Pin 2) or HICCUP OCP (shorting Pin 2 and Pin 3). Connector J₃ provides an option to disable the converter by shorting its Pin 1 and Pin 2.

1.1 Recommended Testing Equipment

The following materials are recommended for testing:

- 0V to 80V power supply with at least 15A source current capability
- Electronic loads capable of sinking current up to 15A
- Digital Multimeters (DMMs)
- 100MHz quad-trace oscilloscope

1.2 Operating Range

The input voltage range is from 32V to 80V for an output voltage of 48V. If the output voltage is set to a lower value, the minimum V_{IN} can be reset to a lower value by changing the ratio of R₂ and R₃. The minimum EN threshold that V_{IN} can be set to is 4.5V.

The rated load current is 10A with the OCP point set at minimum 11A at ambient room temperature conditions. The operating temperature range of this board is from -40°C to +85°C.

Note: Airflow is needed for higher temperature ambient conditions.

1.3 Parallel Operation

The ISL81801DEMO1Z demonstration board can operate in parallel, in a daisy chain setup.

[Figure 2](#) shows the wiring of two units in parallel and [Figure 3](#) shows three units in parallel. The phase shift between the units are set by J₆ and J₇. [Table 2](#) shows the combination.

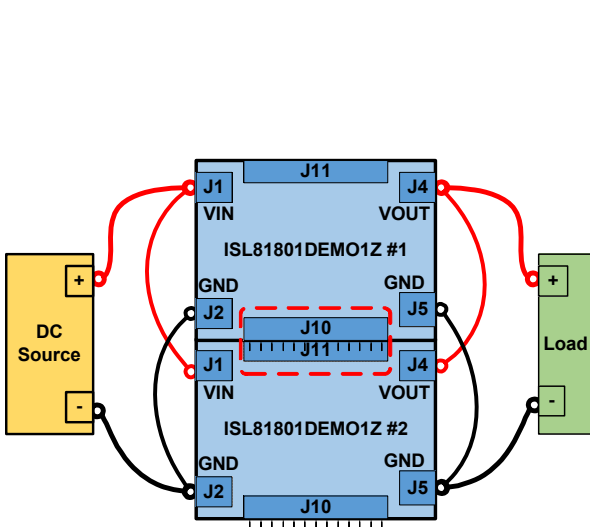

Figure 2. Setup for Two Units in Parallel

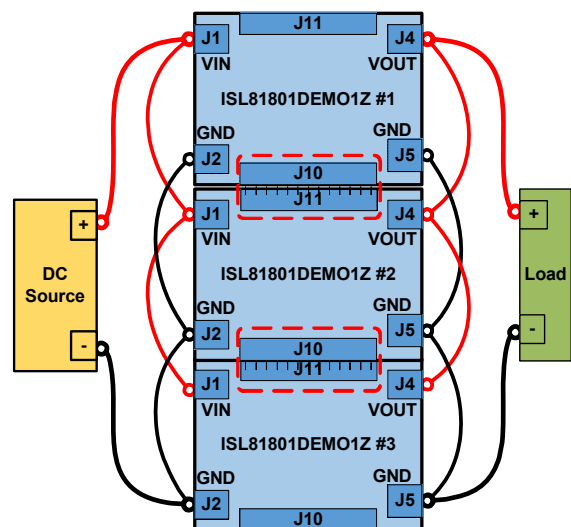

Figure 3. Setup for Three Units in Parallel

Table 2. Set Phase Shift for Interleaving

	CLK Lag RT by (°)	90	60	180	120
J ₇	FBI	VC5 (1)	VC5 (1)	GND (Active)	GND (Active)
J ₆	IIN_B	Open (Active)	Shorted (1)	Open (Active)	Shorted (1)

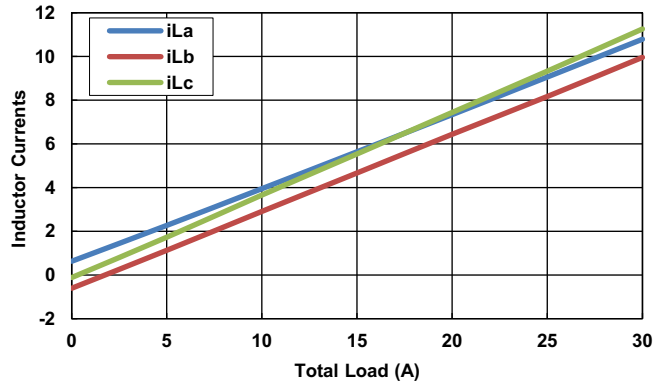

Figure 4. Current Sharing Among Three Units

1.4 Bidirectional Operation

See [Figure 5](#) for proper setup. Float the FBI pin (J₇) and set the mode to PWM before powering on the board. The rated voltage of the super capacitor must be higher than 48V.

1. Adjust the input voltage higher than 36V. Switch on the input power source.
2. Switch off the input power source after the super capacitor is fully charged.

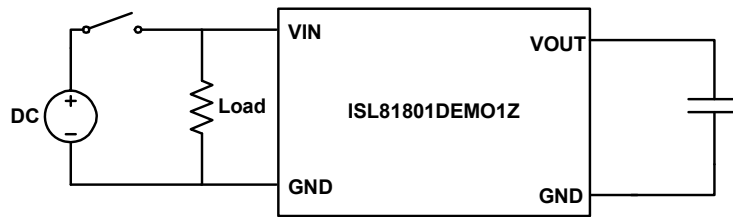

Figure 5. Proper Set-Up for Bidirectional Operation

1.5 Quick Test Guide

1. Jumper J₈ provides the option to select PWM or DEM. Jumper J₉ provides the option to select Constant current limit or HICCUP. See [Table 3](#) for the operating options. Ensure that the circuit is correctly connected to the supply and electronic loads prior to applying any power. See [Figure 7](#) for proper setup.
2. Turn on the power supply.
3. Adjust input voltage V_{IN} within the specified range and observe the output voltage. The output voltage variation should be within 3%.
4. Adjust the load current within the specified range and observe the output voltage. The output voltage variation should be within 3%.
5. Use an oscilloscope to observe output voltage ripple and phase node ringing. For accurate measurement, see [Figure 6](#) for proper test setup.

Table 3. Operating Options

Jumper	Position	Function
3	EN-GND	Disable output
	EN Floating	Enable output
6	I _{IN} Floating	Enable input current limit
	I _{IN} -VCC5	Disable input current limit
7	FBI-GND	Disable V _{IN} limit
	FBI Floating	Enable V _{IN} limit
8	Pin 1-2	PWM
	Pin 2-3	DEM
9	Pin 1-2	Constant current limit
	Pin 2-3	HICCUP

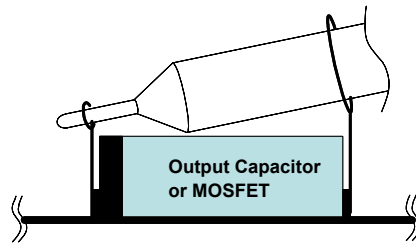

Figure 6. Proper Probe Set-Up to Measure Output Ripple and Phase Node Ringing

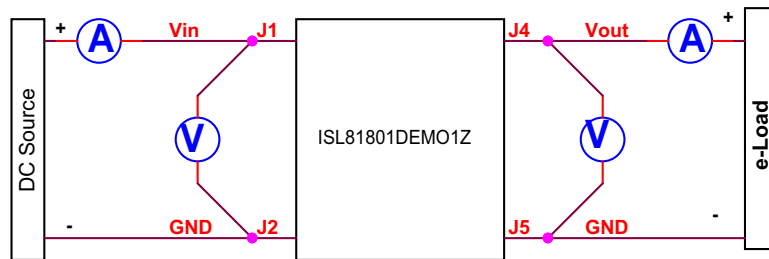

Figure 7. Proper Test Setup

2. PCB Layout Guidelines

Careful attention to layout requirements is necessary for successful implementation of an ISL81801 based DC/DC converter. The ISL81801 switches at a high frequency; therefore the switching times are short. At these switching frequencies, even the shortest trace has significant impedance. The peak gate drive current also rises significantly in an extremely short time. Transition speed of the current from one device to another causes voltage spikes across the interconnecting impedances and parasitic circuit elements. These voltage spikes can degrade efficiency, generate EMI, and increase device voltage stress and ringing. Careful component selection and proper PC board layout minimizes the magnitude of these voltage spikes.

Three sets of components are critical when using the ISL81801 DC/DC converter:

- Controller
- Switching power components
- Small signal components

The switching power components are the most critical to the layout because they switch a large amount of energy, which tends to generate a large amount of noise. The critical small signal components are those connected to sensitive nodes or those supplying critical bias currents. A multilayer printed circuit board is recommended.

Complete the following steps to optimize the PCB layout.

1. Place the input capacitors, buck FETs, inductor, boost FETs, and output capacitor first. Isolate these power components on dedicated areas of the board with their ground terminals adjacent to one another. Place the input and output high frequency decoupling ceramic capacitors close to the MOSFETs.
2. If signal components and the IC are placed separately from the power train, Renesas recommends using full ground planes in the internal layers with shared SGND and PGND to simplify the layout design. Otherwise, use separate ground planes for the power ground and the small signal ground. Connect the SGND and PGND together close to the IC. DO NOT connect them together anywhere else.
3. **Important:** Keep the loop formed by the input capacitor, the buck top FET, and the buck bottom FET as small as possible. Also, keep the loop formed by the output capacitor, the boost top FET, and the boost bottom FET as small as possible.
4. Ensure the current paths from the input capacitor to the buck FETs, the power inductor, the boost FETs, and the output capacitor are as short as possible with maximum allowable trace widths.
5. Place the PWM controller IC close to the lower FETs. The low-side FETs gate drive connections should be short and wide. Place the IC over a quiet ground area. Avoid switching ground loop currents in this area.
6. Place the VDD bypass capacitor close to the VDD pin of the IC and connect its ground end to the PGND pin. Connect the PGND pin to the ground plane by a via.
Note: Do not connect the PGND pin directly to the SGND EPAD.
7. Place the gate drive components (BOOT diodes and BOOT capacitors) together near the controller IC.
8. Place the output capacitors as close to the load as possible. Use short, wide copper regions to connect output capacitors to the load to avoid inductance and resistance.
9. Use copper filled polygons or wide, short traces to connect the junction of the buck or boost upper FET, buck or boost lower FET, and output inductor. Keep the buck and boost PHASE nodes connection to the IC short.
Important: DO NOT unnecessarily oversize the copper islands for the PHASE nodes. Because the phase nodes are subjected to high dv/dt voltages, the stray capacitor formed between these islands and the surrounding circuitry tend to couple switching noise.
10. Route all high speed switching nodes away from the control circuitry.
11. Create a separate small analog ground plane near the IC. Connect the SGND pin to this plane. Connect all small signal grounding paths including feedback resistors, current monitoring resistors and capacitors, soft-starting capacitors, loop compensation capacitors and resistors, and EN pull-down resistors to this SGND plane.

12. Use a pair of traces with minimum loop for the input or output current sensing connection.
13. Ensure the feedback connection to the output capacitor is short and direct.

2.1 ISL81801DEMO1Z Demonstration Board



Figure 8. ISL81801DEMO1Z Demonstration Board (Top)

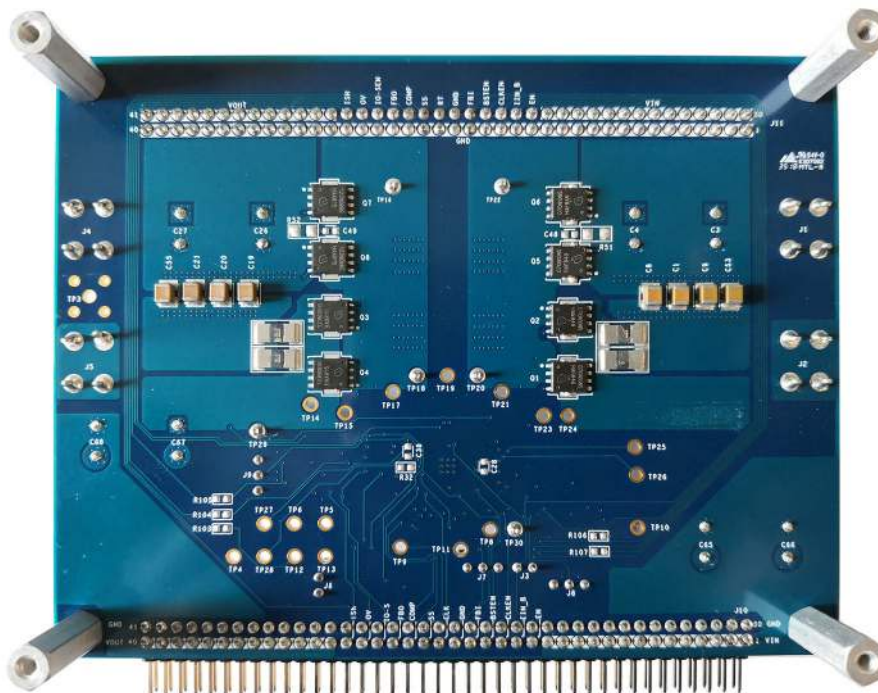

Figure 9. ISL81801DEMO1Z Demonstration Board (Bottom)

2.2 ISL81801DEMO1Z Circuit Schematic

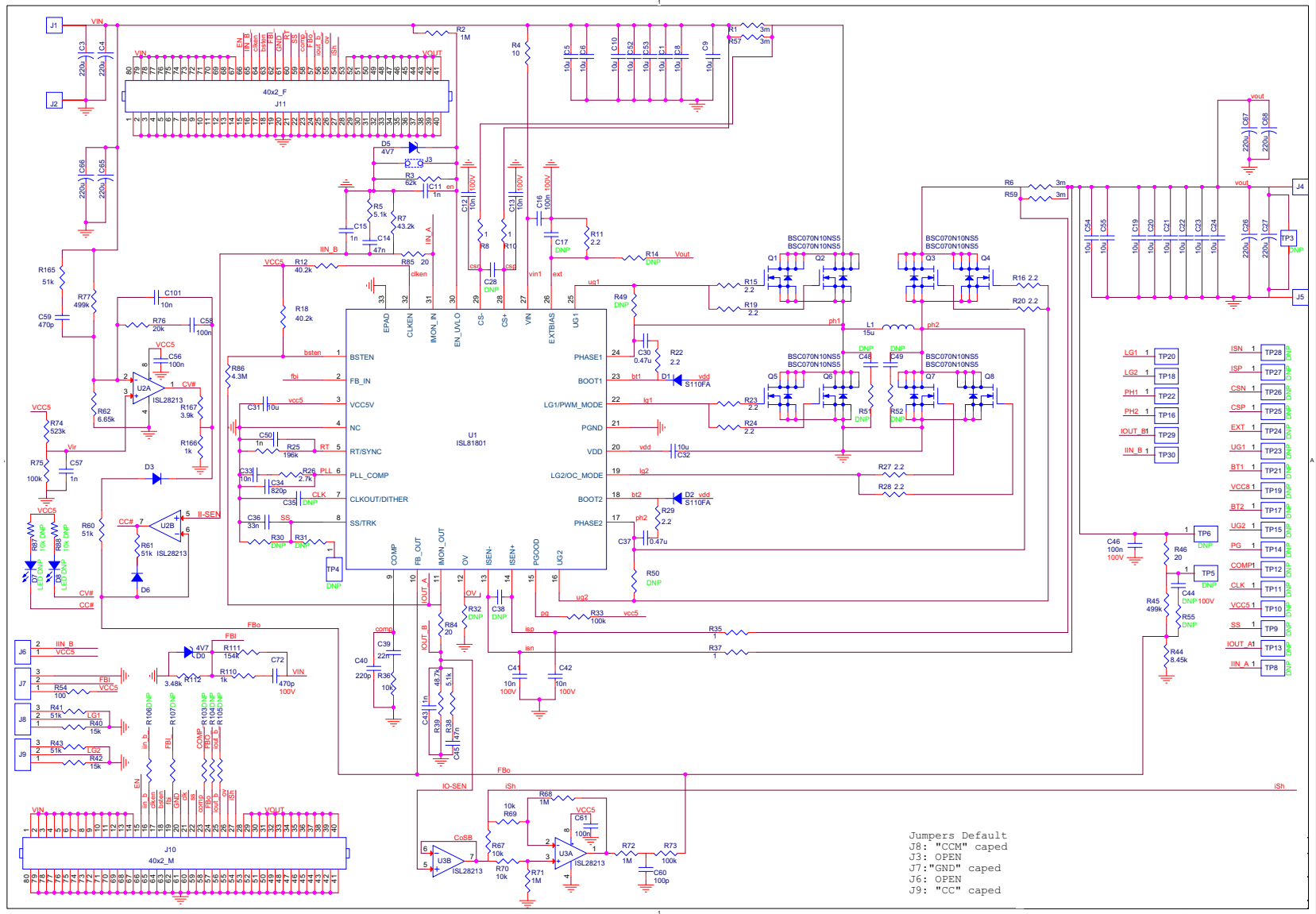

Figure 10. Schematic

2.3 Bill of Materials

Qty	Reference Designator	Description	Manufacturer	Manufacturer Part
2	C31, C32	CAP, SMD, 0805, 10µF, 16V, 10%, X7S	Murata	GRM21BC71C106KE11L
16	C1, C5, C6, C8-C10, C19-C24, C52-C55	CAP, SMD, 1210, 10µF, 100V, 10%, X7S	Murata	GRM32EC72A106KE05L
1	C60	CAP, SMD, 0603, 100pF, 50V, 10%, X7R	Kemet	C0603C101K5RACTU
3	C11, C15, C43	CAP, SMD, 0603, 1000pF, 50V, 10%, X7R	AVX	06035C102KAT2A
2	C50, C57	CAP, SMD, 0603, 1000pF, 50V, 10%, X7R	AVX	06035C102KAT2A
5	C12, C13, C41, C42, C101	CAP, SMD, 0603, 0.01µF, 100V, 10%, X7R	Kemet	C0603C103K1RECAUTO
1	C33	CAP, SMD, 0603, 0.01µF, 50V, 10%, X7R	AVX	06035C103KAT2A
2	C16, C46	CAP, SMD, 0603, 0.1µF, 100V, 10%, X7R	Venkel	C0603X7R101-104KNE
3	C56, C58, C61	CAP, SMD, 0603, 0.1µF, 50V, 10%, X7R	AVX	06035C104KAT2A
1	C40	CAP, SMD, 0603, 220pF, 50V, 10%, X7R	Murata	GRM188R71H221KA01D
1	C39	CAP, SMD, 0603, 0.022µF, 25V, 10%, X7R	Murata	GRM188R71E223KA01J
1	C36	CAP, SMD, 0603, 33000pF, 25V, 10%, X7R	Panasonic	ECJ-1VB1E333K
2	C59, C72	CAP, SMD, 0603, 470pF, 100V, 10%, X7R	Vishay	VJ0603Y471KXBA
2	C14, C45	CAP, SMD, 0603, .047µF, 25V, 10%, X7R	Murata	GRM188R71E473KA01D
2	C30, C37	CAP, SMD, 0603, 0.47µF, 25V, 10%, X7R	Murata	GRM188R71E474KA12D
1	C34	CAP, SMD, 0603, 820pF, 50V, 10%, X7R	Kemet	C0603C821K5RACTU
0	C17, C28, C35, C38, C44, C48, C49	CAP, SMD, 0603, DNP-PLACE HOLDER		
1	L1	COIL-PWR INDUCTOR, 15µH, 14A, 9mΩ, SMD, 18.3, x9.1, WW	Würth Elektronik	74439370150
8	C3, C4, C26, C27, C65, C66, C67, C68	CAP, RADIAL, 12.5x26.5, 220µF, 100V, 20%, ALUM.ELEC., 5mm	United Chemi-con Panasonic	EKZN101ELL221MK25S EEUFS2A221
6	TP16, TP18, TP20, TP22, TP29, TP30	CONN-COMPACT TEST PT, VERTICAL, WHT	Keystone	5007
1	J10	CONN-HEADER, TH, 2x40, R/A, 2.54mmPITCH, 11x5mm	Würth Elektronik	61308021021 (or two 40 pin)
2	J3, J6	CONN-HEADER, 1x2, BRKAWY 1x36, 2.54mm	Berg/FCI	68000-236HLF
3	J7, J8, J9	CONN-HEADER, 1x3, BREAKAWY 1x36, 2.54mm	Berg/FCI	68000-236HLF
1	D3	DIODE-SCHOTTKY, AEC-Q101, SMD, 2P, SOD-123, 30V, 200mA	Nexperia USA, Inc	BAT54GWJ
2	D5, D0	DIODE-ZENER, SMD, SOD-323, 4.7V, 6%, 200mW	Micro Commercial Components	BZT52C4V7S-TP
2	D1, D2	DIODE-SCHOTTKY, AEC-Q101, SMD, SOD-123FA, 100V, 1A	ON Semiconductor	S110FA
2	U2, U3	IC-DUAL OP AMP, RRIO, 8P, MSOP	Renesas Electronics America	ISL28213FUZ
1	U1	IC-80V 4-SWITCH PWM CONTROLLER, 32P, TQFN, 5x5	Renesas Electronics America	ISL81801FRTZ
8	Q1, Q2, Q3, Q4, Q5, Q6, Q7, Q8	TRANSISTOR-MOS, N-CHANNEL, SMD, 8P, PPK SO-8, 100V, 80A, ROHS	Infineon Technology	BSC070N10NS5ATMA1
4	R8, R10, R35, R37	RES, SMD, 0603, 1Ω, 1/10W, 1%, TF	Panasonic	ERJ-3RQF1R0V
1	R4	RES, SMD, 0603, 10Ω, 1/10W, 1%, TF	KOA	RK73H1JT10R0F

Qty	Reference Designator	Description	Manufacturer	Manufacturer Part
3	R46, R84, R85	RES, SMD, 0603, 20Ω, 1/10W, 1%, TF	Panasonic	ERJ-3EKF20R0V
11	R11, R15, R16, R19, R20, R22-R24, R27-R29	RES, SMD, 0603, 2.2Ω, 1/10W, 1%, TF	Panasonic	ERJ-3RQF2R2V
1	R54	RES, SMD, 0603, 100Ω, 1/10W, 1%, TF	Venkel	CR0603-10W-1000FT
2	R110, R166	RES, SMD, 0603, 1k, 1/10W, 1%, TF	Panasonic	ERJ-3EKF1001V
4	R36, R67, R69, R70	RES, SMD, 0603, 10k, 1/10W, 1%, TF	Venkel	CR0603-10W-1002FT
3	R33, R73, R75	RES, SMD, 0603, 100k, 1/10W, 1%, TF	Venkel	CR0603-10W-1003FT
3	R68, R71, R72	RES, SMD, 0603, 1M, 1/10W, 1%, TF	Panasonic	ERJ-3EKF1004V
2	R40, R42	RES, SMD, 0603, 15k, 1/10W, 1%, TF	Panasonic	ERJ-3EKF1502V
1	R25	RES, SMD, 0603, 196k, 1/10W, 1%, TF	Panasonic	ERJ-3EKF1963V
1	R76	RES, SMD, 0603, 20k, 1/10W, 1%, TF	Venkel	CR0603-10W-2002FT
1	R26	RES, SMD, 0603, 2.7k, 1/10W, 1%, TF	Venkel	CR0603-10W-2701FT
1	R112	RES, SMD, 0603, 3.48k, 1/10W, 1%, TF	Panasonic	ERJ-3EKF3481V
1	R167	RES, SMD, 0603, 3.9k, 1/10W, 1%, TF	Panasonic	ERJ-3EKF3901V
2	R12, R18	RES, SMD, 0603, 40.2k, 1/10W, 1%, TF	Yageo	RC0603FR-0740K2L
1	R86	RES, SMD, 0603, 4.3M, 1/10W, 1%, TF	Stackpole	RMCF0603FT4M30
1	R7	RES, SMD, 0603, 43.2k, 1/10W, 1%, TF	Yageo	RC0603FR-0743K2L
1	R39	RES, SMD, 0603, 48.7k, 1/10W, 1%, TF	Panasonic	ERJ-3EKF4872V
2	R5, R38	RES, SMD, 0603, 5.1k, 1/10W, 1%, TF	Venkel	CR0603-10W-5101FT
5	R41, R43, R60, R61, R165	RES, SMD, 0603, 51k, 1/10W, 1%, TF	Yageo	RC0603FR-0751KL
1	R74	RES, SMD, 0603, 523k, 1/10W, 1%, TF	Yageo	RC0603FR-07523KL
1	R3	RES, SMD, 0603, 62k, 1/10W, 1%, TF	Yageo	RC0603FR-0762KL
1	R62	RES, SMD, 0603, 4.7k, 1/10W, 1%, TF	Yageo	RC0603FR-074K7L
1	R44	RES, SMD, 0603, 8.45k, 1/10W, 1%, TF	Yageo	RC0603FR-078K45L
0	R14, R30, R31, R32, R49, R50, R55, R87, R88 R103, R104, R105, R106, R107	RES, SMD, 0603, DNP-PLACE HOLDER		
1	R2	RES, SMD, 1206, 1M, 1/4W, 1%, TF	Venkel	CR1206-4W-1004FT
1	R111	RES, SMD, 1206, 154k, 1/4W, 1%, TF	Yageo	RC1206FR-07154KL
2	R45, R77	RES, SMD, 1206, 499k, 1/4W, 1%, TF	Venkel	CR1206-4W-4993FT
0	R51, R52	RES, SMD, 1206, DNP, DNP, DNP, TF		
4	R1, R6, R57, R59	RES-AEC-Q200, SMD, 2512, 0.003Ω, 1W, 1%, CURR.SENSE, MF	Vishay/Dale	WSL25123L000FEA
4	J1, J2, J4, J5	HDWARE, TERMINAL, M4 METRIC SCREW, TH, 4P, SNAP-FIT	Keystone	7795
1	J11	CONN-SOCKET HEADER, TH, 2x40, R/A, 2.54mmPITCH, 12.6x5mm	Würth Elektronik	61308024312 (or 2 x 613040243121)
0	D6, D7, D8, TP3 TP4-TP6, TP8-TP10, TP11-TP15, TP17, TP19, TP21, TP23-TP28	DO NOT POPULATE OR PURCHASE		

2.4 Board Layout

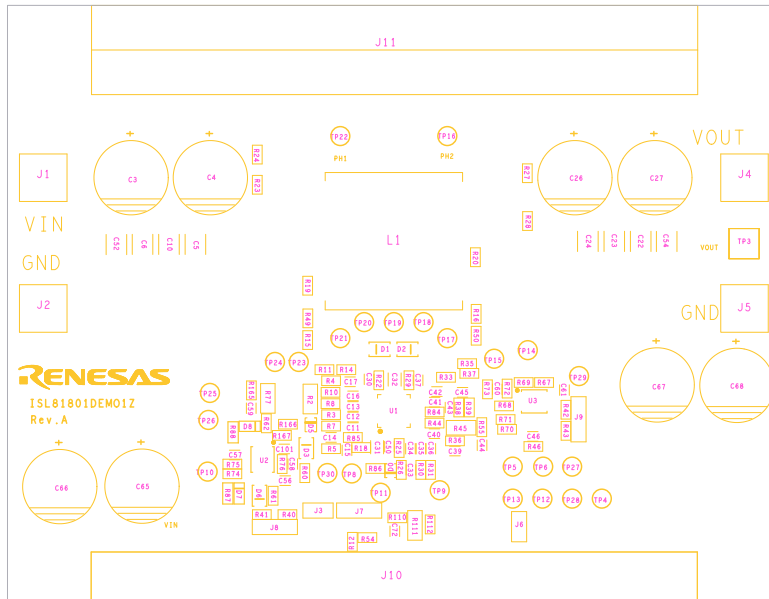

Figure 11. Assembly Top

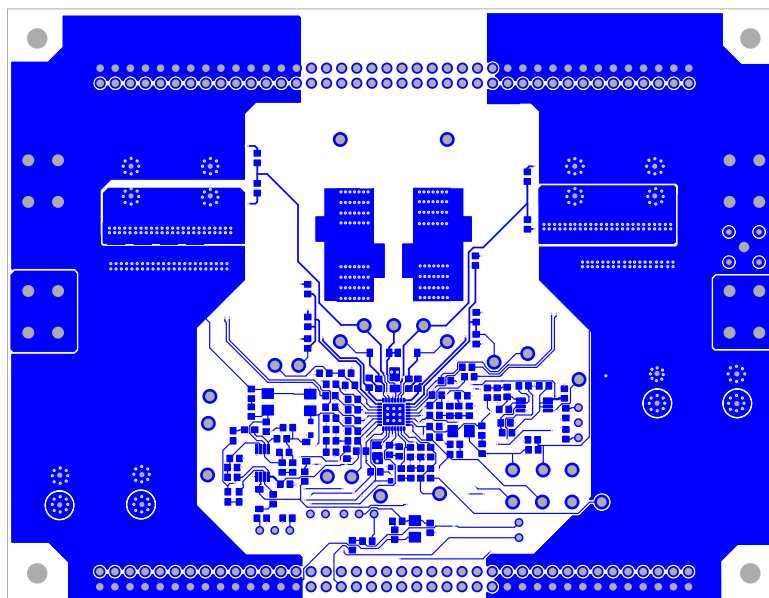

Figure 12. Top Layer

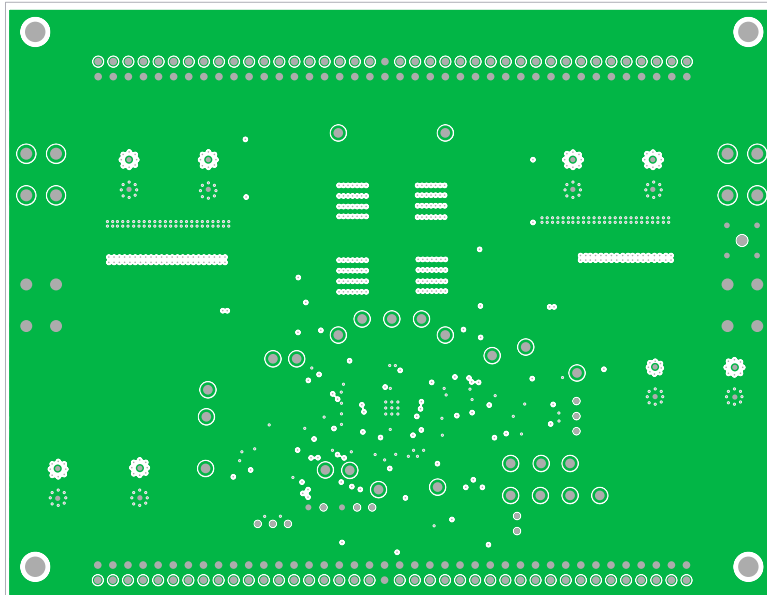

Figure 13. Layers 2 and 3 (Solid Ground), Identical

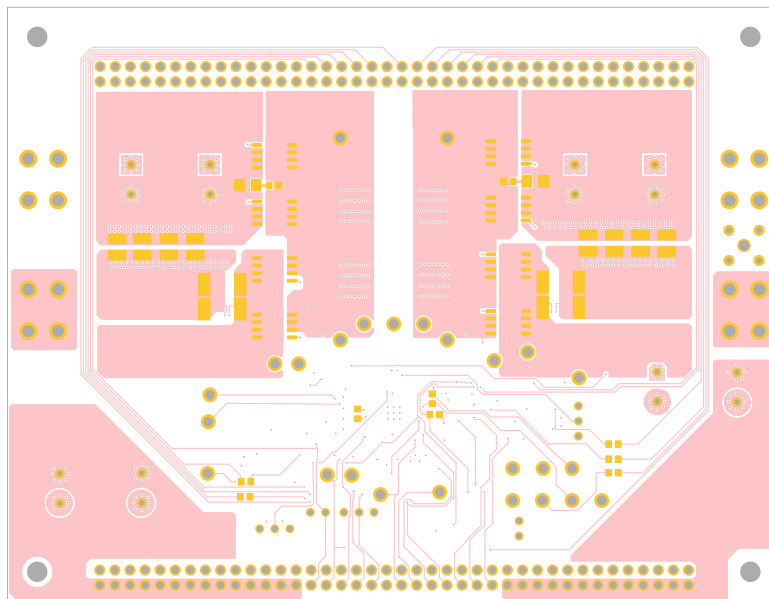

Figure 14. Bottom Layer

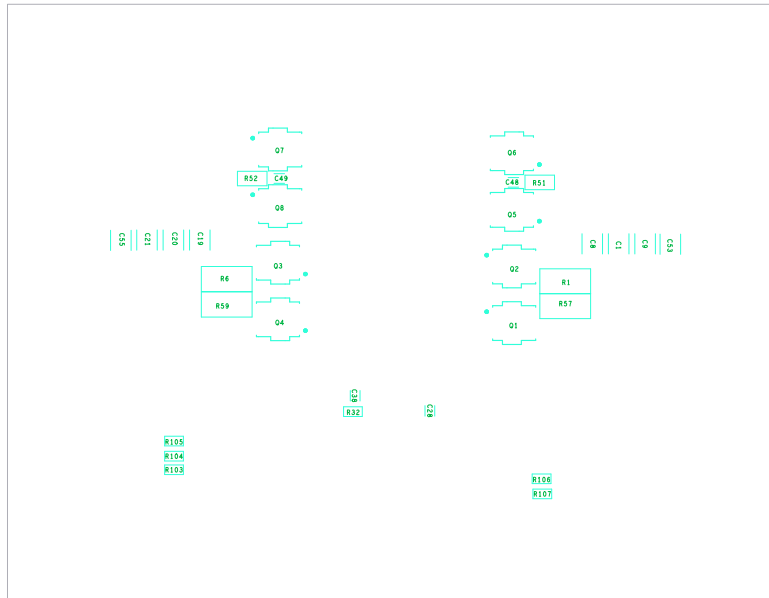

Figure 15. Assembly Bottom

3. Typical Performance Curves

$V_{IN} = 48V$, $R_{62} = 4.7k$, unless otherwise noted.

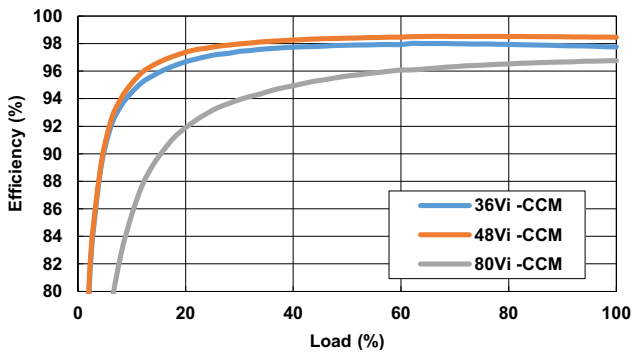

Figure 16. Efficiency, CCM

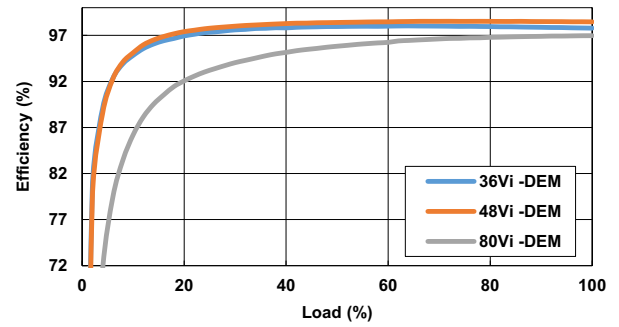

Figure 17. Efficiency, DEM

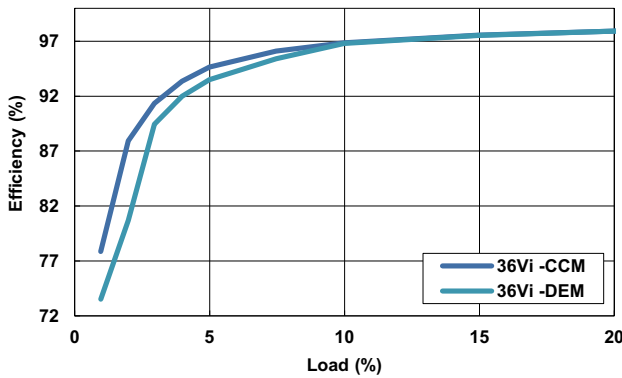

Figure 18. DEM vs CCM at Light Load, $V_{IN} = 36V$

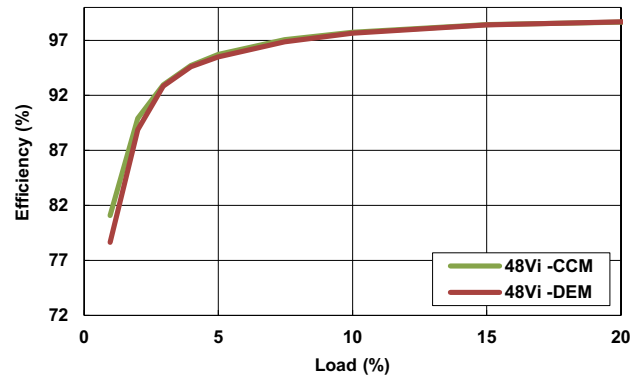

Figure 19. DEM vs CCM at Light Load, $V_{IN} = 48V$

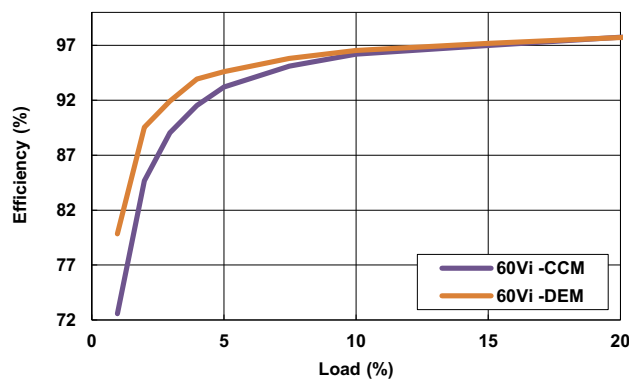

Figure 20. DEM vs CCM at Light Load, $V_{IN} = 60V$

$V_{IN} = 48V$, $R_{62} = 4.7k$, unless otherwise noted. (Continued)

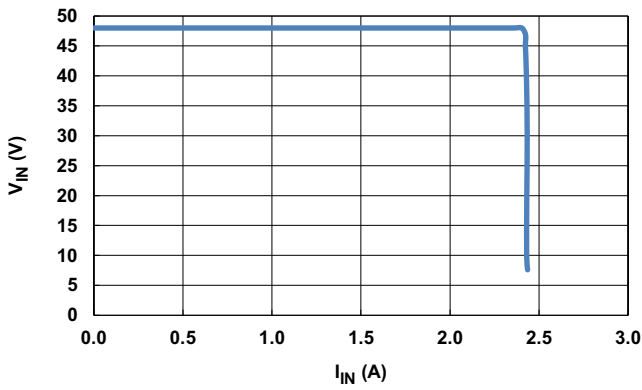

Figure 21. Input Port CV/CC Regulation ($R_{62} = 8.45k$)

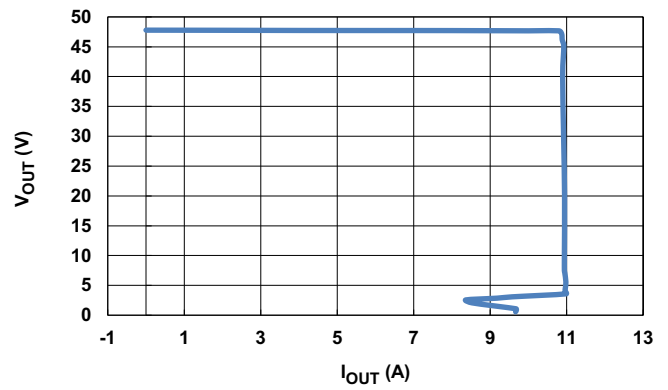

Figure 22. Output Port CV/CC Regulation (48V, 11A)

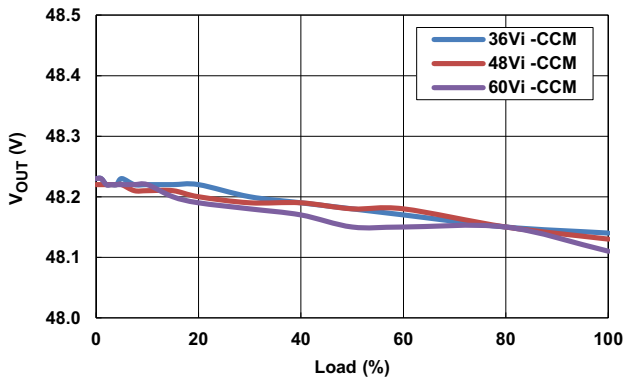

Figure 23. Load Regulation, CCM

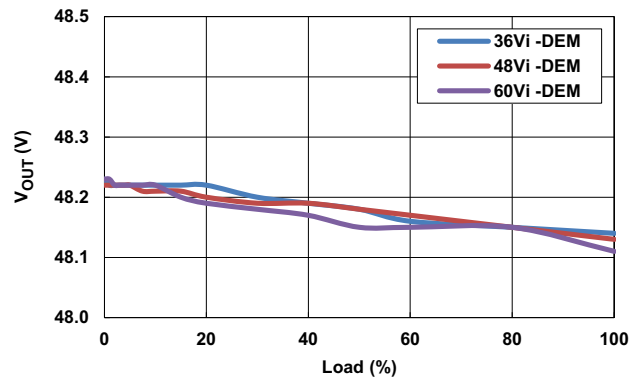

Figure 24. Load Regulation, DEM

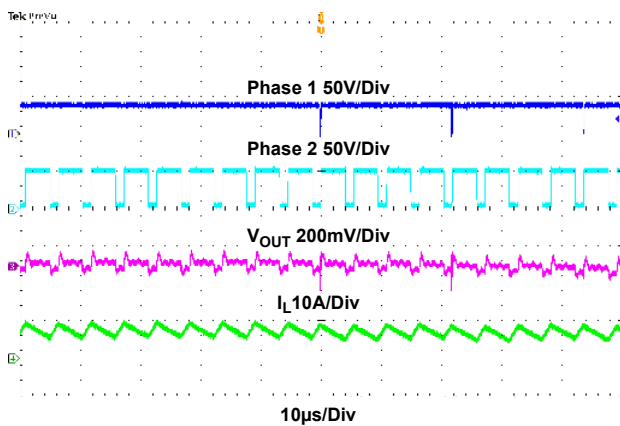

Figure 25. Phase 1, Phase 2, V_{OUT} and Inductor Current, $V_{IN} = 36V$, $I_{OUT} = 5A$

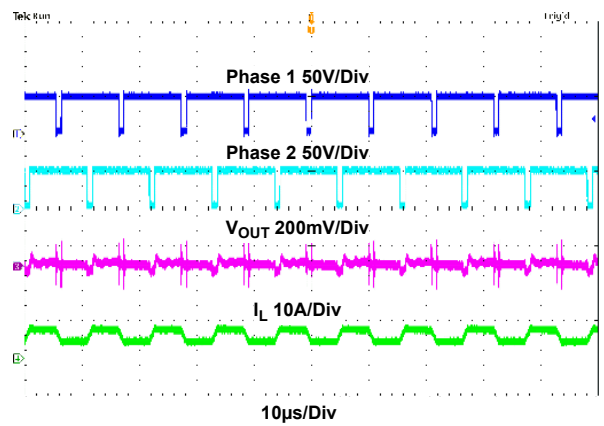

Figure 26. Phase 1, Phase 2, V_{OUT} and Inductor Current, $V_{IN} = 48V$, $I_{OUT} = 5A$

$V_{IN} = 48V$, $R_{62} = 4.7k$, unless otherwise noted. (Continued)

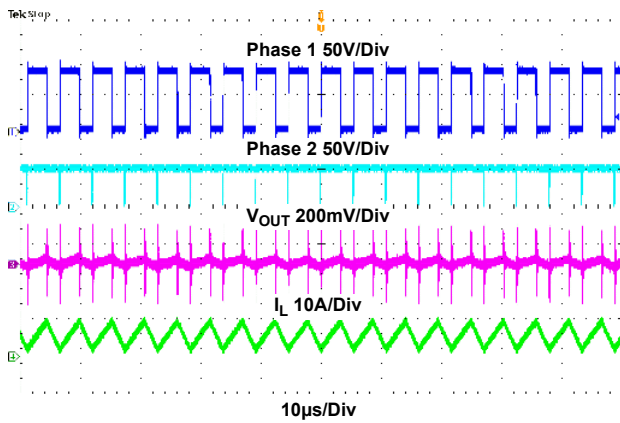

Figure 27. Phase 1, Phase 2, V_{OUT} and Inductor Current, $V_{IN} = 80V$, $I_{OUT} = 5A$

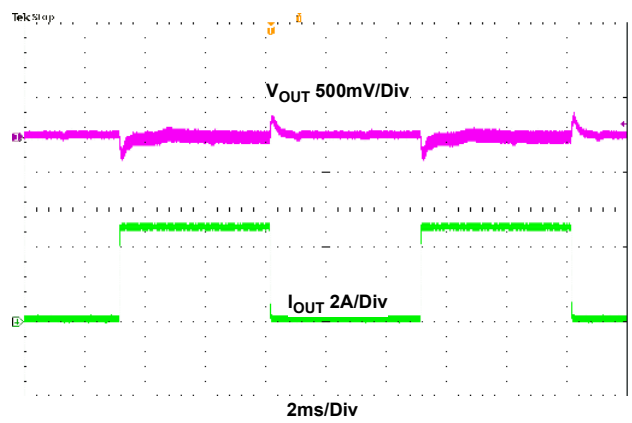

Figure 28. Load Transient, $V_{IN} = 36V$, $I_{OUT} = 0A$ to $5A$ $2.5A/\mu s$, CCM

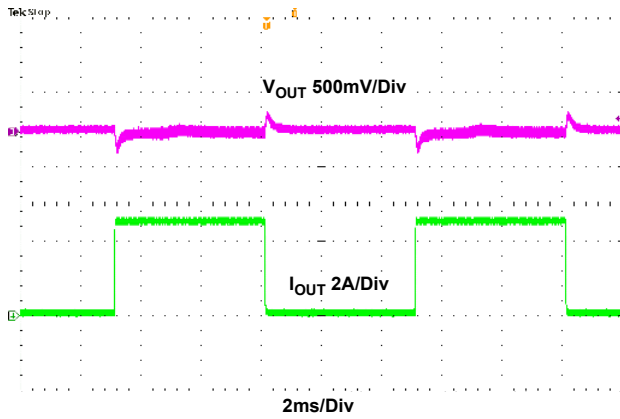

Figure 29. Load Transient, $V_{IN} = 48V$, $I_{OUT} = 0A$ to $5A$ $2.5A/\mu s$, CCM

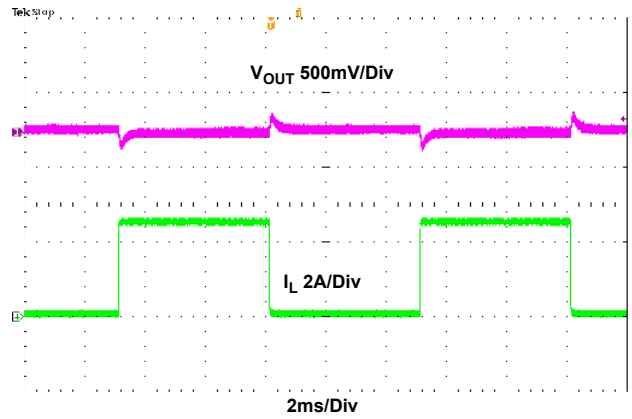

Figure 30. Load Transient, $V_{IN} = 80V$, $I_{OUT} = 0A$ to $5A$ $2.5A/\mu s$, CCM

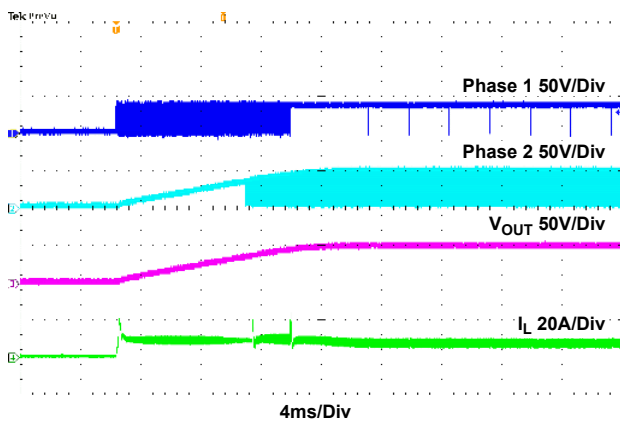

Figure 31. Start-Up Waveform, $V_{IN} = 36V$, $I_{OUT} = 5A$, CCM

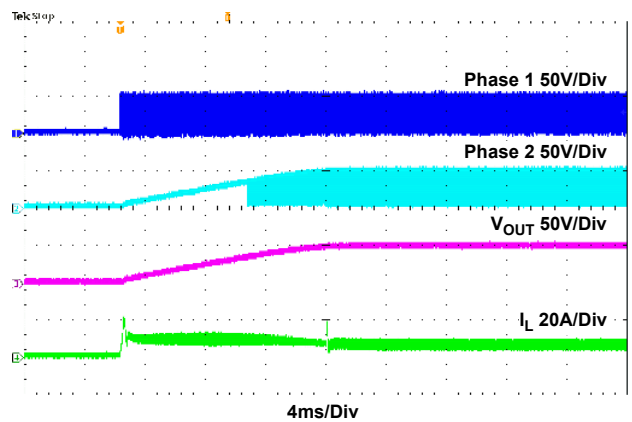

Figure 32. Start-Up Waveform, $V_{IN} = 48V$, $I_{OUT} = 5A$, CCM

$V_{IN} = 48V$, $R_{62} = 4.7k$, unless otherwise noted. (Continued)

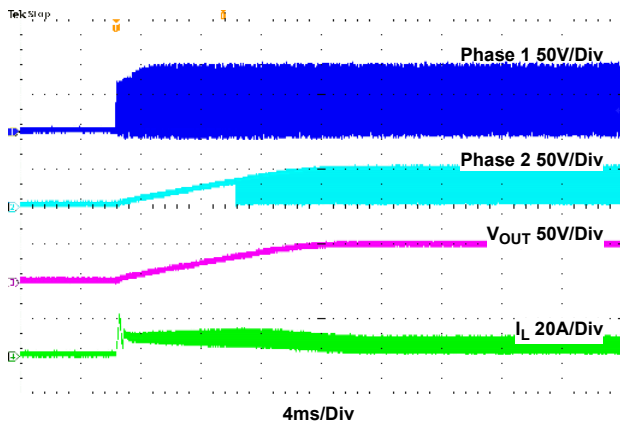

Figure 33. Start-Up Waveform, $V_{IN} = 80V$, $I_{OUT} = 5A$, CCM

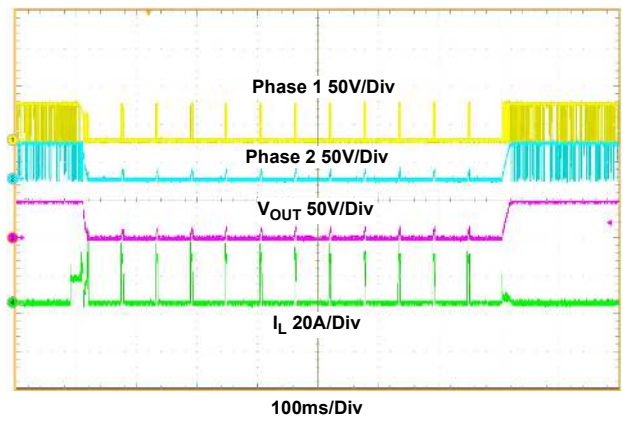

Figure 34. Short-Circuit Waveform

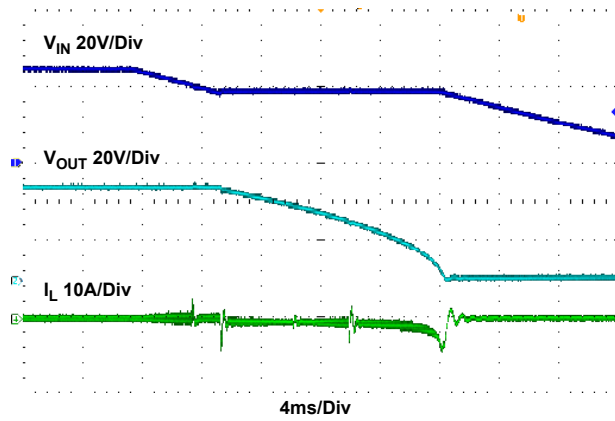

Figure 35. Bidirectional Operation, $V_{IN} = 48V$, $V_{in_limit} = 36V$, $I_{IN} = 1A$

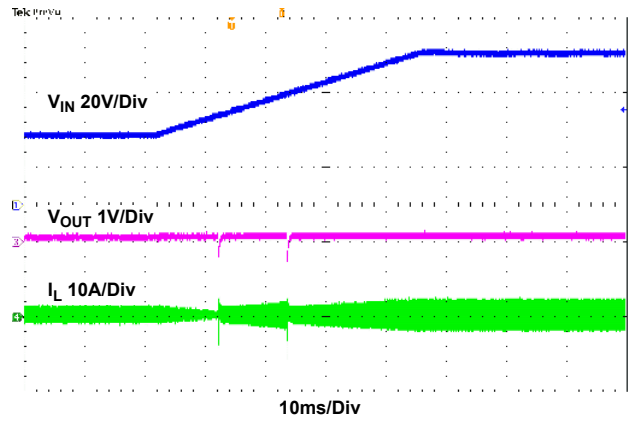

Figure 36. Line Transient, $V_{IN} = 36V$ to $80V$, $1V/ms$, $I_{OUT} = 0A$

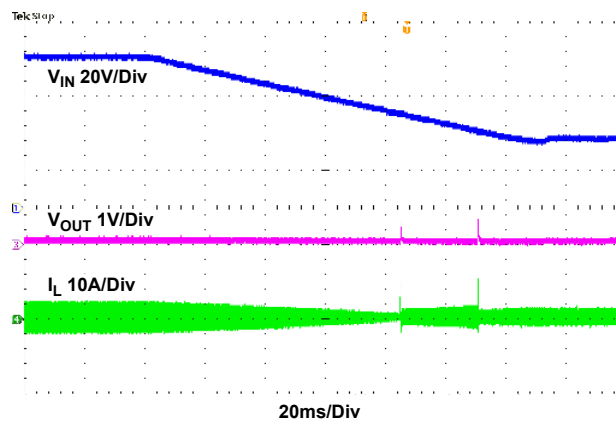

Figure 37. Line Transient, $V_{IN} = 80V$ to $36V$, $1V/ms$, $I_{OUT} = 0A$

4. Revision History

Rev.	Date	Description
1.00	Oct.16.20	Initial release

IMPORTANT NOTICE AND DISCLAIMER

RENESAS ELECTRONICS CORPORATION AND ITS SUBSIDIARIES (“RENESAS”) PROVIDES TECHNICAL SPECIFICATIONS AND RELIABILITY DATA (INCLUDING DATASHEETS), DESIGN RESOURCES (INCLUDING REFERENCE DESIGNS), APPLICATION OR OTHER DESIGN ADVICE, WEB TOOLS, SAFETY INFORMATION, AND OTHER RESOURCES “AS IS” AND WITH ALL FAULTS, AND DISCLAIMS ALL WARRANTIES, EXPRESS OR IMPLIED, INCLUDING, WITHOUT LIMITATION, ANY IMPLIED WARRANTIES OF MERCHANTABILITY, FITNESS FOR A PARTICULAR PURPOSE, OR NON-INFRINGEMENT OF THIRD PARTY INTELLECTUAL PROPERTY RIGHTS.

These resources are intended for developers skilled in the art designing with Renesas products. You are solely responsible for (1) selecting the appropriate products for your application, (2) designing, validating, and testing your application, and (3) ensuring your application meets applicable standards, and any other safety, security, or other requirements. These resources are subject to change without notice. Renesas grants you permission to use these resources only for development of an application that uses Renesas products. Other reproduction or use of these resources is strictly prohibited. No license is granted to any other Renesas intellectual property or to any third party intellectual property. Renesas disclaims responsibility for, and you will fully indemnify Renesas and its representatives against, any claims, damages, costs, losses, or liabilities arising out of your use of these resources. Renesas' products are provided only subject to Renesas' Terms and Conditions of Sale or other applicable terms agreed to in writing. No use of any Renesas resources expands or otherwise alters any applicable warranties or warranty disclaimers for these products.

(Rev.1.0 Mar 2020)

Corporate Headquarters

TOYOSU FORESIA, 3-2-24 Toyosu,
Koto-ku, Tokyo 135-0061, Japan
www.renesas.com

Contact Information

For further information on a product, technology, the most up-to-date version of a document, or your nearest sales office, please visit:
www.renesas.com/contact/

Trademarks

Renesas and the Renesas logo are trademarks of Renesas Electronics Corporation. All trademarks and registered trademarks are the property of their respective owners.