

SPECIFICATION CONTROL DRAWING

THIS DRAWING CONTAINS INFORMATION PROPRIETARY TO RF INDUSTRIES, LTD. ANY UNAUTHORIZED USE OF THIS DRAWING IS EXPRESSLY PROHIBITED. ANY VIOLATION IS PUNISHABLE UNDER U.S. COPYRIGHT LAWS.

REV	DESCRIPTION	DWN	DATE	APPROVED
A	ENGINEERING RELEASE	KMM	3/7/99	R. RICE
B	CHNG CRIMP DIE TO .130	DM	2005	R. RICE

008974

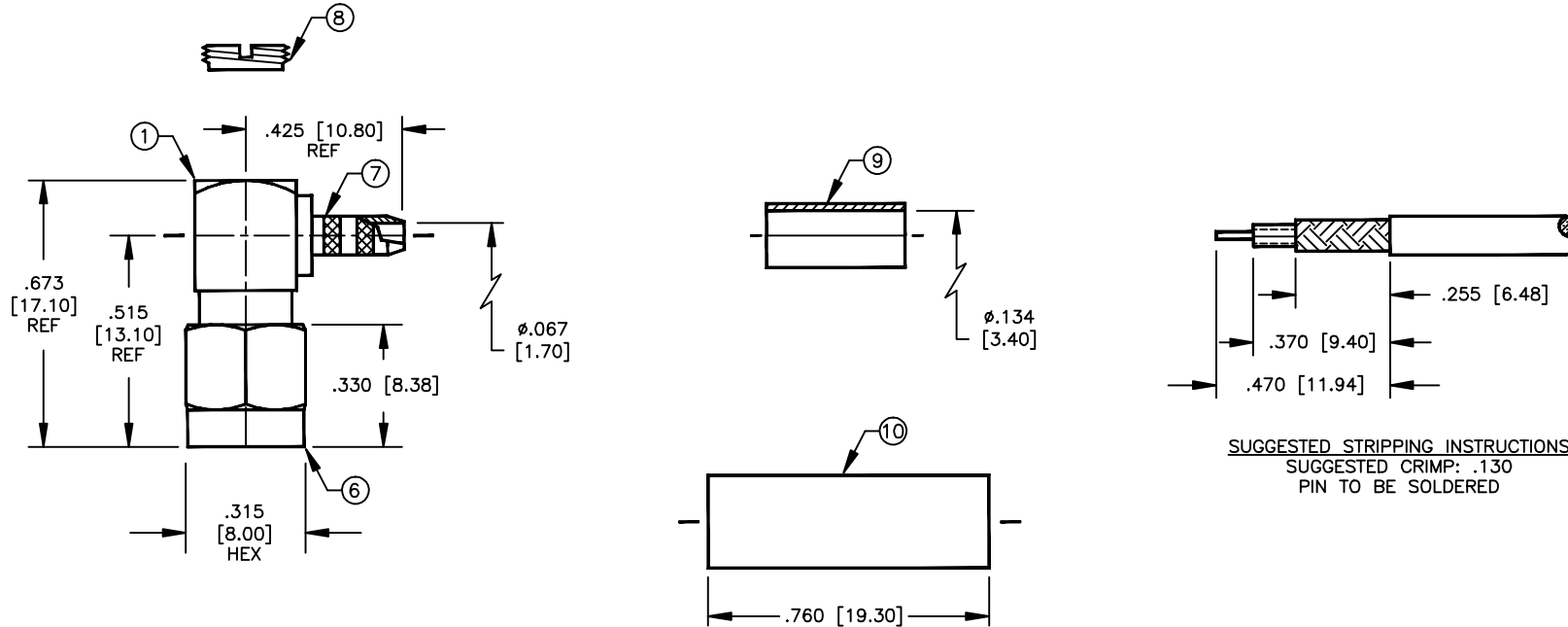

SPECIFICATIONS:

IMPEDANCE: 50 OHMS
 WORKING VOLTAGE: 375V PEAK @ SEA LEVEL
 FREQUENCY RANGE: 0-12.4 GHz
 INSERTION LOSS: ≤ -.2 dB @ 6 GHz
 VSWR MAX: 1.3:1 @ 6 GHz
 FOR RG-316/U DOUBLE SHIELD CABLE

ALL DIMENSIONS ARE REFERENCE ONLY

DIMENSIONS ARE IN INCHES AND [MILLIMETERS]

UNLESS OTHERWISE NOTED TOLERANCES ARE:
DECIMALS DIAMETER

DRAWN
K. MAXWELL 3/7/99

CHECKED

ORJ DRAWN
K. MAXWELL 3/7/99

APPROVALS DATE

RFconnectors

DIVISION OF RF INDUSTRIES, LTD.

7610 MIRAMAR RD
 SAN DIEGO, CA 92126
 (619)549-6340
 (619)549-6345 FAX

RSA-3010-B1

SMA MALE RIGHT ANGLE CRIMP

SIZE A	CABLE GROUP B1	DWG NO. RSA-3010-B1	REV B
SCALE: 2:1		CAD FILE 13ARC B	SHEET 1 OF 1

ITEM	DESCRIPTION	QTY	MATERIAL	FINISH
10	TUBING [TUB-S187-BK]	1	HEAT SHRINK	BLACK
9	FERRULE [FR-44-34X95C]	1	COPPER	NICKEL
8	END CAP	1	BRASS	NICKEL
7	FERRULE STUD	1	BRASS	NICKEL
6	SHELL	1	BRASS	NICKEL
5	RETAINING RING	1	BeCu	NONE
4	GASKET	1	S.I. RUBBER	RED
3	DIELECTRIC	1	PTFE	NONE
2	PIN	1	BRASS	GOLD
1	BODY	1	BRASS	NICKEL