

Designated client product

This product will be discontinued its production in the near term.
And it is provided for customers currently in use only, with a time limit.
It can not be available for your new project. Please select other new or existing products.

For more information, please contact our sales office in your region.

New Japan Radio Co.,Ltd.

www.njr.com

DOUBLE BALANCED MODULATION / DEMODULATOR

■ GENERAL DESCRIPTION

The **NJM1496** is a double balanced modulator-demodulator which produces an output voltage proportional to the product of an input (signal) voltage and a switching (carrier) signal. Typical applications include suppressed carrier modulation, amplitude modulation, synchronous detection, FM or PM detection, broadband frequency doubling and chopping.

■ FEATURES

- Excellent carrier suppression
65dB typical at 0.5MHz
50dB typical at 10MHz
- Adjustable gain and signal handling
- Fully balanced inputs and outputs
- High Common Mode Rejection 85dB Typ.
- Package Outline DIP14, DMP14, SSOP14
- Bipolar Technology

■ APPLICATION

- Balanced Modulation
- Synchronous Detection
- FM Detection
- Phase Detection
- Sampling

■ PIN CONFIGURATION

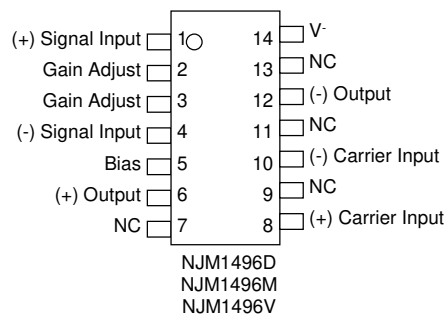

■ EQUIVALENT CIRCUIT

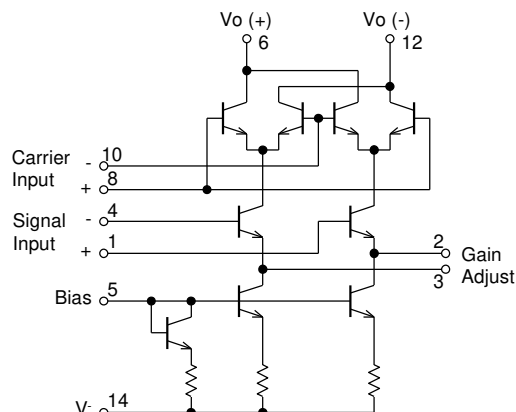

■ PACKAGE OUTLINE

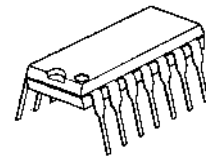

NJM1496D

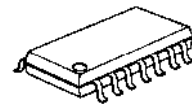

NJM1496M



NJM1496V

NJM1496

■ ABSOLUTE MAXIMUM RATINGS

($T_a=25^\circ\text{C}$)

PARAMETER	RATINGS	UNIT
Applied Voltage	30 (Applied Pins 6-8, 12-8, 6-10, 12-10, 10-1, 8-1, 10-4, 8-4, 2-5, 3-5)	V
Carrier Input Voltage	± 5 (Applied Pins 8-10)	V
Signal Input Voltage	$\pm(5+I_5 \cdot R_e)$ (Applied Pins 1-4)	V
Input Signal	5	V
Bias Current (I_5)	10	mA
Power Dissipation	(DIP14) 570	mW
	(DMP14) 300	mW
	(SSOP14) 300	mW
Operating Temperature Range	-40 to +85	$^\circ\text{C}$
Storage Temperature Range	-40 to +125	$^\circ\text{C}$

■ ELECTRICAL CHARACTERISTICS

DC characteristics ($V^+=12\text{V}$, $V^-=-8\text{V}$, $I_5=1.0\text{mA}$, $R_L=3.9\text{k}\Omega$, $R_e=1.0\text{k}\Omega$, $T_a=25^\circ\text{C}$)

PARAMETER	SYMBOL	TEST CONDITION	MIN.	TYP.	MAX.	UNIT
Single-Ended Input Impedance						
Parallel Input Resistance	R_{ip}	Signal Port, $f=5.0\text{MHz}$	-	200	-	$\text{k}\Omega$
Parallel Input Capacitance	C_{ip}	Signal Port, $f=5.0\text{MHz}$	-	2.0	-	pF
Single-Ended Output Impedance						
Parallel Output Resistance	R_{op}	$f=10\text{MHz}$	-	40	-	$\text{k}\Omega$
Parallel Output Capacitance	C_{op}	$f=10\text{MHz}$	-	5.0	-	pF
Input Bias Current						
$I_{bs}=I_1+I_4/2$	I_{bs}		-	12	30	μA
$I_{bs}=I_8+I_{10}/2$	I_{bc}		-	12	30	μA
Input Offset Current						
$I_{ios}=I_1-I_4$	I_{ios}		-	0.7	7	μA
$I_{ios}=I_8-I_{10}$	I_{ioc}		-	0.7	7	μA
Average Temperature Coefficient of Input Offset Current	ΔI_{io}		-	2.0	-	$\text{nA}/^\circ\text{C}$
Output Offset Current						
(I_6-I_{12})	I_{oc}		-	15	80	μA
Average Temperature Coefficient of Output Offset Current	ΔI_{oc}		-	90	-	$\text{nA}/^\circ\text{C}$
Output Voltage	V_O		-	8.0	-	V
Operating Current						
(I_6+I_{12})	I_{D+}		-	2.0	4.0	mA
I_{14}	I_{D-}		-	3.0	5.0	mA
DC Power Dissipation	P_D		-	33	-	mW

■ **ELECTRICAL CHARACTERISTICS** AC characteristics ($V^+=12V$, $V^-=-8V$, $I_5=1.0mA$, $R_L=3.9k\Omega$, $R_e=1.0k\Omega$, $T_a=25^\circ C$)

PARAMETER	SYMBOL	TEST CONDITION	MIN.	TYP.	MAX.	UNIT
Carrier Feedthrough	V_{CFT}	$V_C=60mV_{rms}$ sine wave offset adjusted	-	40	-	μV_{rms}
		$f_C=1.0kHz$	-	140	-	μV_{rms}
	V_{CFT}	$V_C=300mV_{P-P}$ square wave $f_C=1.0kHz$ offset adjusted	-	0.04	0.4	mV_{rms}
		offset not adjusted	-	20	200	mV_{rms}
		$f_S=10kHz$, $300mV_{rms}$ sine wave offset adjusted	-	-	-	-
Carrier Suppression	V_{CS}	$f_C=500kHz$, $60mV_{rms}$ sine wave	40	65	-	dB
	V_{CS}	$f_C=10MHz$, $60mV_{rms}$ sine wave	-	50	-	dB
Transadmittance Bandwidth ($R_L=50\Omega$)		$V_C=60mV_{rms}$ sine wave				
Carrier Input Port	BW 3dB	$f_S=1.0kHz$, $300mV_{rms}$ sine wave	-	300	-	MHz
Signal Input Port	BW 3dB	$V_S=300mV_{rms}$ sine wave $ V_C =0.5V_{dc}$		80		MHz
Voltage Gain, Signal Channel	AV_S	$V_S=100mV_{rms}$, $f_S=1.0kHz$ $ V_C =0.5V_{dc}$	2.5	3.5	-	V / V
Signal Port Common Mode Input Voltage Range	CM_V	$f_S=1.0kHz$	-	5.0	-	V_{P-P}
Signal Port Common Mode Rejection Ratio	ACM	$f_S=1.0kHz$, $ V_C =0.5V_{dc}$	-	-85	-	dB
Differential Output Swing Capability	DV_{out}		-	8.0	-	V_{P-P}

■ **TEST CIRCUIT**

- Carrier Feedthrough
- Carrier Suppression

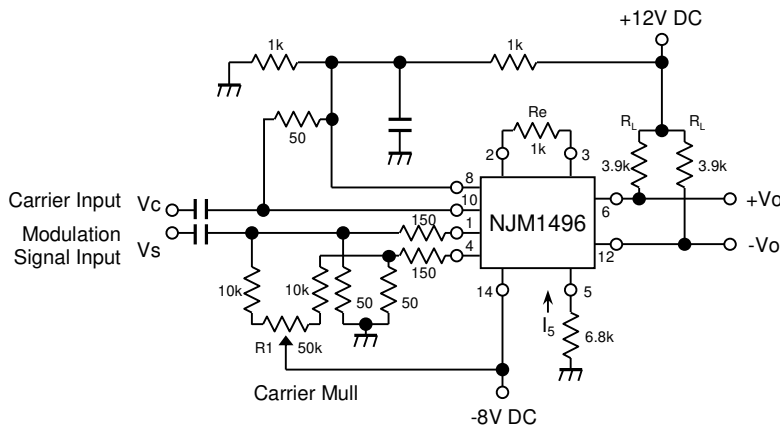

- Differential Output Swing Capability
- Signal Port Common Mode Rejection Ratio

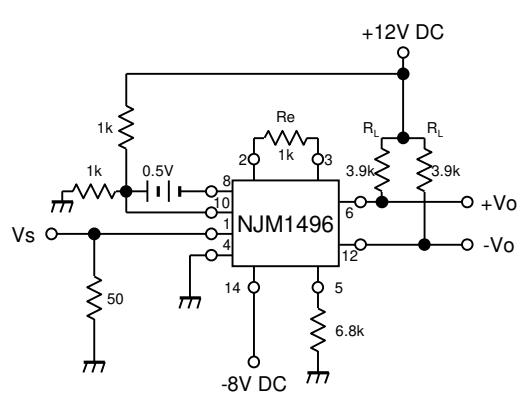

Connect a 100uF capacitor and a 3000pF capacitor in parallel to each other, if the capacitance is not specified.

■ TYPICAL CHARACTERISTICS

Carrier Suppression versus Carrier Input Level

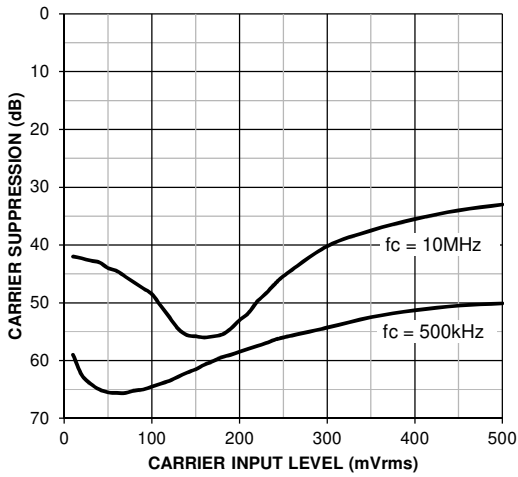

Carrier Feedthrough versus Frequency

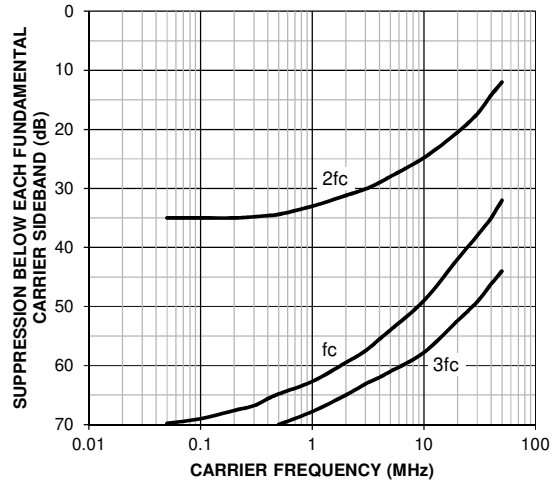

Carrier Feedthrough versus Frequency

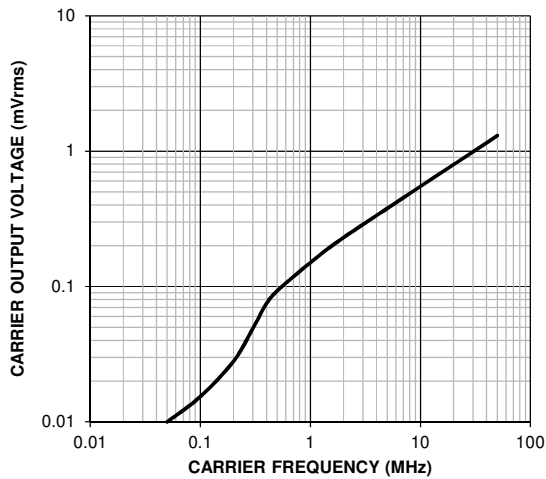

Sideband Output versus Carrier Levels

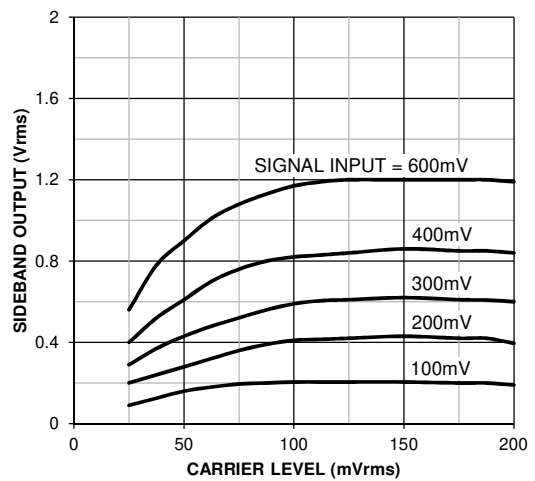

Carrier Suppression versus Temperature

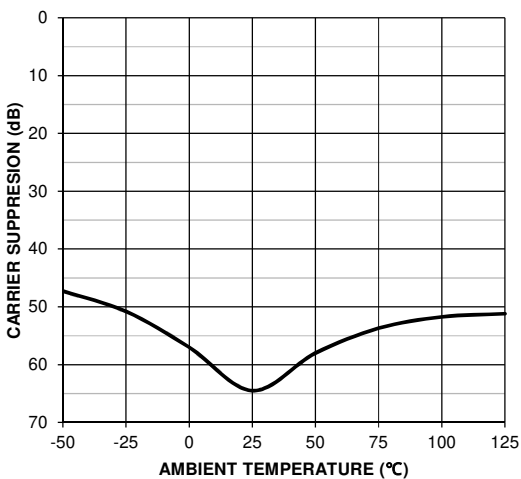

■ TYPICAL APPLICATIONS

AM Modulator Circuit

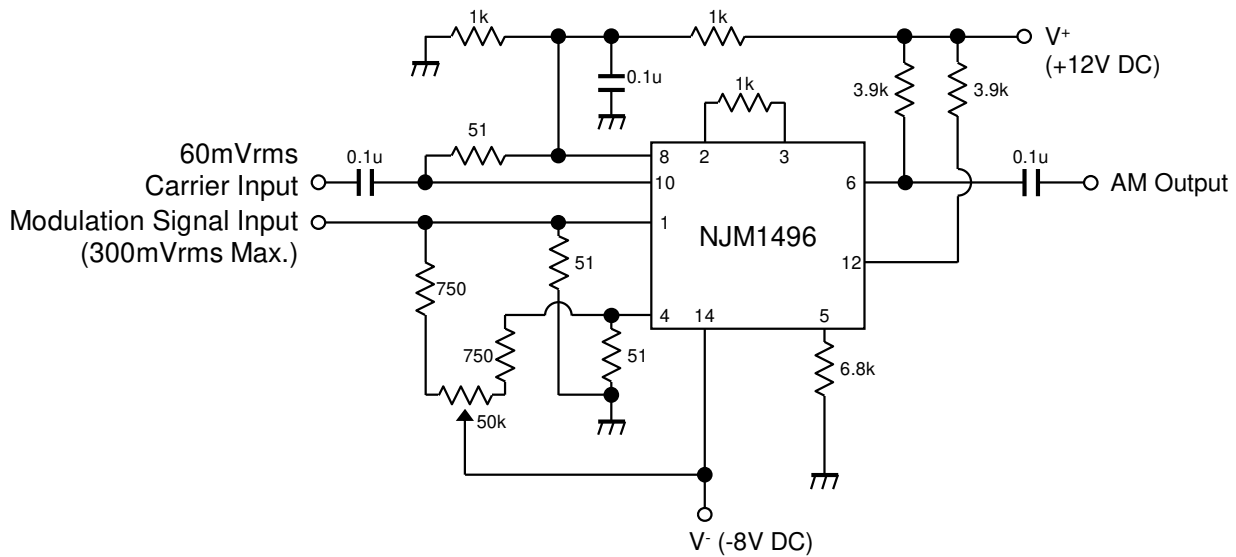

Product Detector (+12V DC Single Supply)

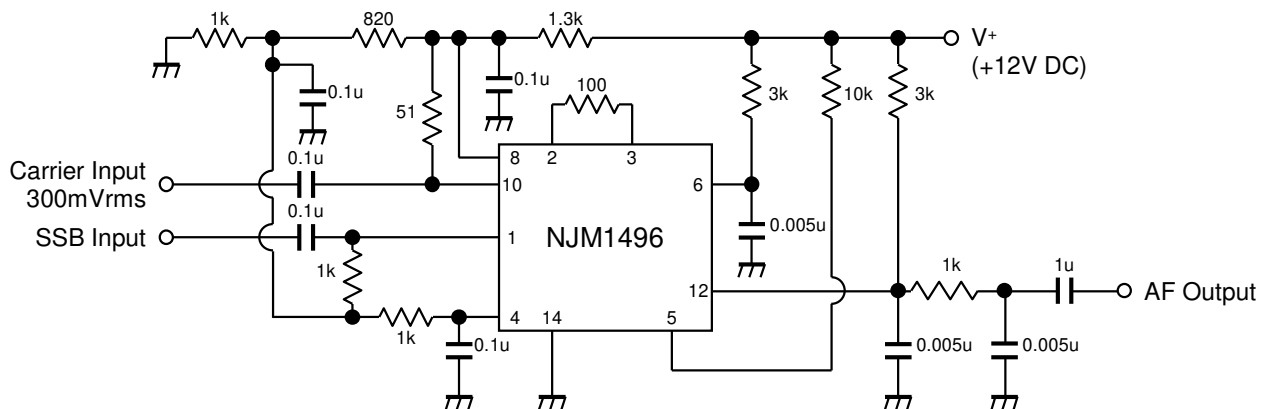

[CAUTION]

The specifications on this databook are only given for information, without any guarantee as regards either mistakes or omissions. The application circuits in this databook are described only to show representative usages of the product and not intended for the guarantee or permission of any right including the industrial rights.