

LOC		DIST		REVISIONS			
DF	DO	REV	DATE	BY	CHK	APPV	
F		1	REVISED PER ECO-10-025541	24DEC10	SK	RL	

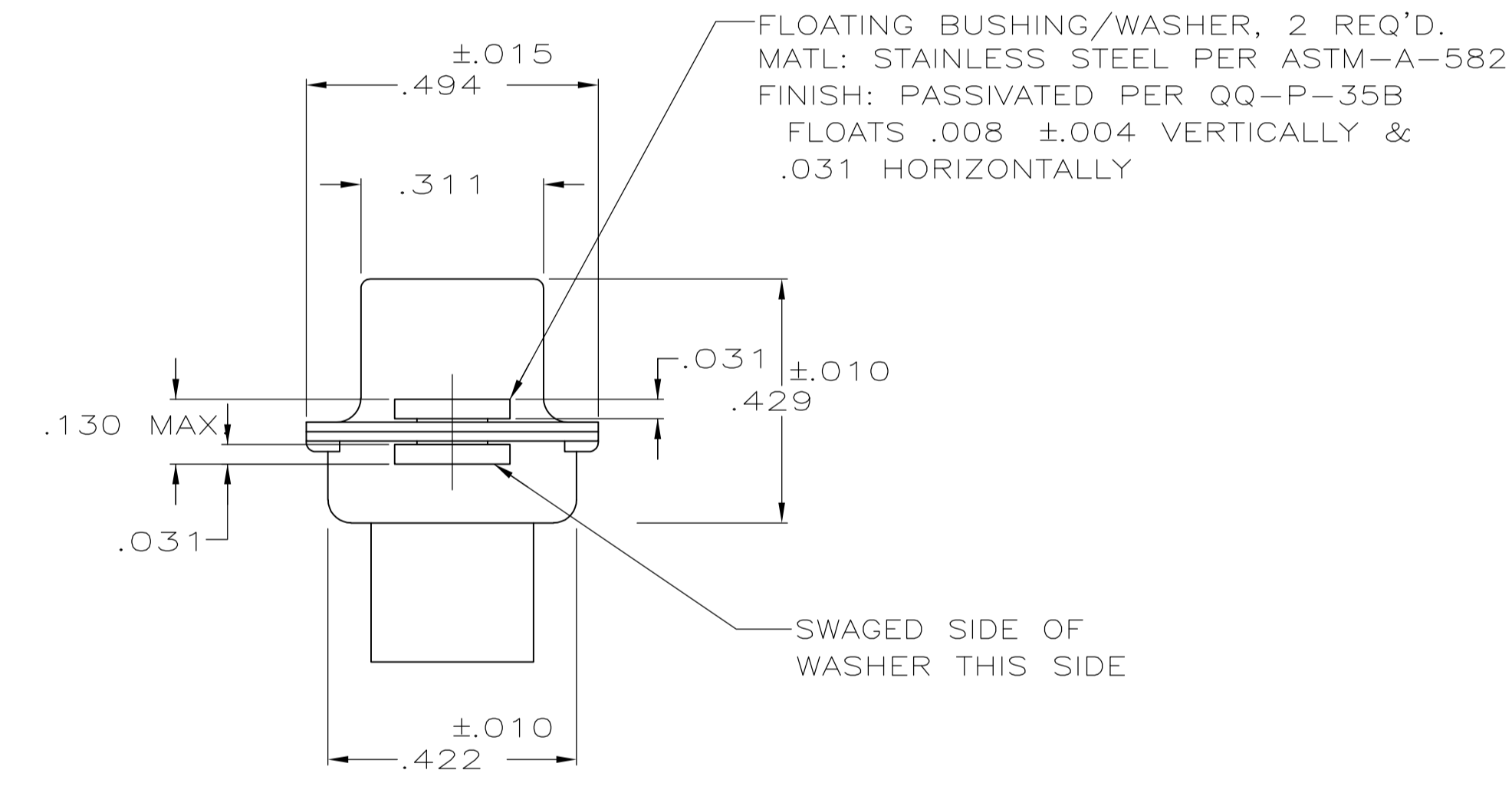
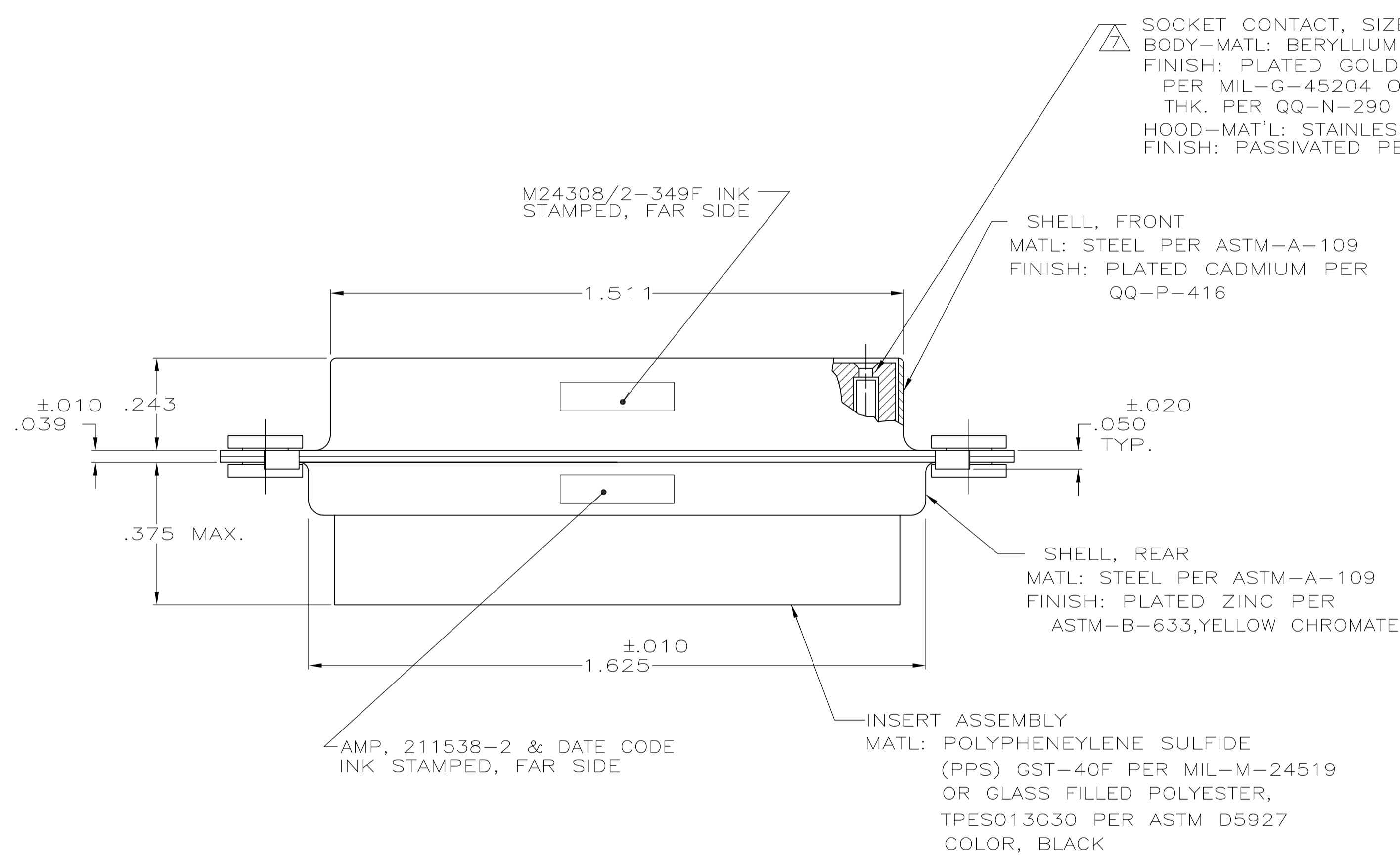
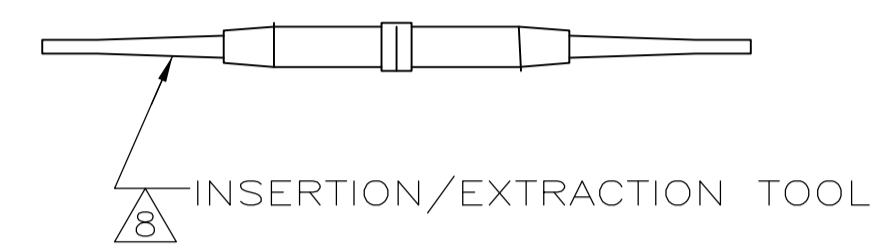
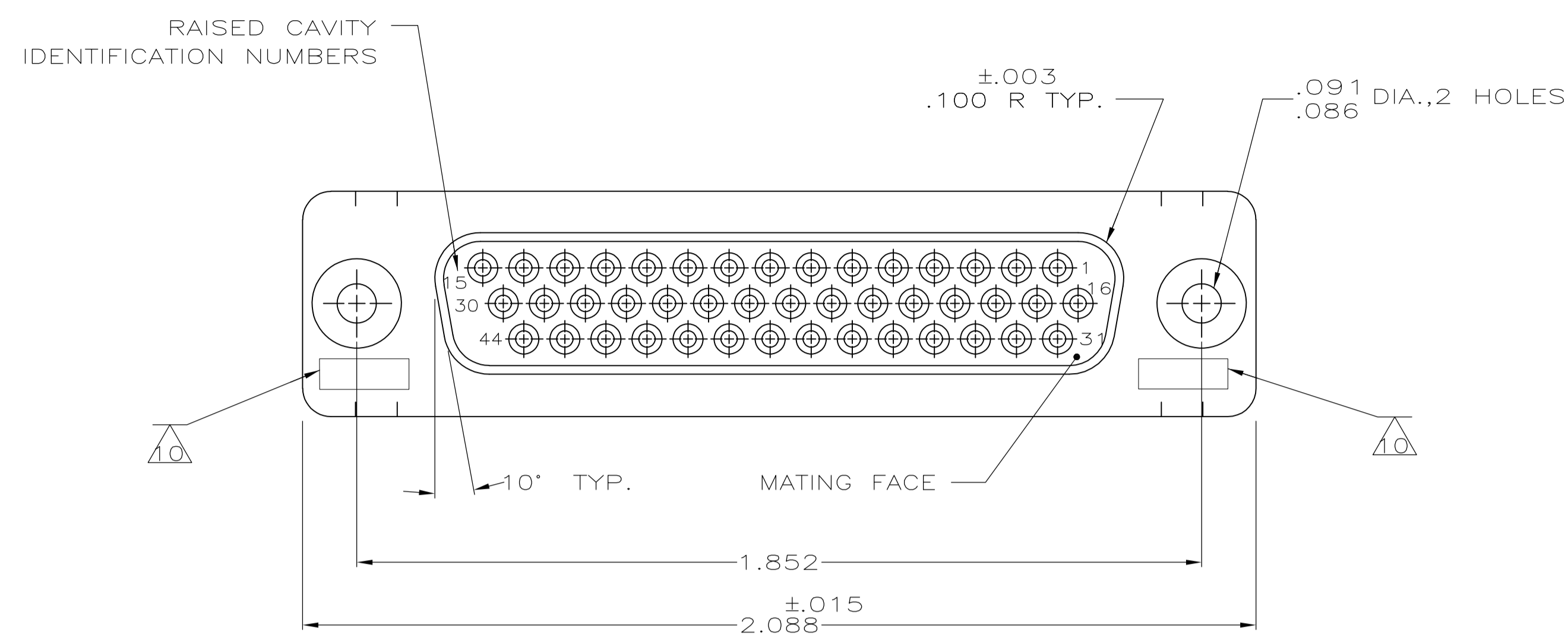

SOCKET CONTACT, SIZE 22, 44 REQD.
 BODY-MATL: BERYLLIUM COPPER PER QQ-C-530
 FINISH: PLATED GOLD .000050 MIN. THK.
 PER MIL-G-45204 OVER NICKEL .000050 MIN. THK. PER QQ-N-290
 HOOD-MAT'L: STAINLESS STEEL PER QQ-S-766
 FINISH: PASSIVATED PER QQ-P-35B

- THIS RECEPTACLE WILL MATE WITH ANY 44 POSN., SIZE 3 PLUG IN AMPLIMITE SERIES.
- MAXIMUM WIRE INSULATION TO BE USED WITH THIS RECEPTACLE IS .054 DIA.
- SST RETENTION CLIPS ARE INCLUDED IN INSERTS.

- 4 PACKAGE STAMPED M24308/2-489F & AMP P/N 211538-1
- 5 PACKAGE STAMPED M24308/2-349F & AMP P/N 211538-2
- 6 PACKAGE STAMPED M24308/2-360F & AMP P/N 211538-3
- 7 AMP P/N 204351-1; MIL P/N 57-354, INCLUDED IN KIT
- 8 AMP P/N 91067-1; MIL P/N M81969/1-04
- 9 CONNECTOR SUPPLIED WITHOUT CONTACTS; SHOWN FOR ILLUSTRATION ONLY.
- 10 UL/CSA DESIGNATION STAMPED IN THIS AREA, OPTIONAL

DESCRIPTION	PART NO
SUPSD BY 204540-2 & 91067-1	211538-3
SAME AS -1 EXCEPT: 6, 7, 8	211538-2
AS SHOWN	211538-1

THIS DRAWING IS A CONTROLLED DOCUMENT.

DIMENSIONS: INCHES	TOLERANCES UNLESS OTHERWISE SPECIFIED:	0. PLC ± -	1. PLC ± -	2. PLC ± -	3. PLC ± .005	4. PLC ANGLES ± 0°30'
MATERIAL SEE CALLOUT	FINISH SEE CALLOUT	WEIGHT	SIZE A1	CAGE CODE 00779	DRAWING NO. 211538	RESTRICTED TO

CUSTOMER DRAWING SCALE NTS SHEET 1 OF 1 REV F

THIS DRAWING IS A CONTROLLED DOCUMENT. D ERDMAN 6-18-85
 CHK R. GRZYBOWSKI 9-20-85
 APVD G. SACUNAS 9-20-85
 NAME Tyco Electronics Corporation Harrisburg, PA 17105-3608
 PRODUCT SPEC RECEPTACLE ASS'Y., AMPLIMITE 44 POSN., SIZE 3, SERIES 90, W/DUAL FLOATING BUSHINGS
 APPLICATION SPEC