



---

# SPECIFICATION SHEET

Product: CC20150

Model: 2.0 x 150 | 0.286/0.283

# Specifications

1. Available Range. The specifications available to CCFL unit listed on page 1.
2. Product Construction.

Item No.	Name	Requirements	Remark
1	Dimension	Lamp Shape: Straight	Naked lamp
		Dia: $\Phi 2.0 \pm 0.05\text{mm}$	
		Glass tube length: $150 \pm 1.0\text{mm}$	
2	Glass tube	Hard material glass tube	
3	Fluorescent powder	Three primary colors phosphor	
4	Electrode	Kovar	
5	Gas	80 Torr	Ne+Ar(95:5)

3. Primary Characteristics.
  - 3.1. Requests of Specifications

Item No.	Name	Code	Unit	Specification	Remark
1	Lamp Voltage (Reference)	VL	Vrms	$470 \pm 10\%$	KD12300 inverter 12V
2	Lamp Current	IL	MArms	$6.0 \pm 0.2\text{mA}$	
3	Starting Voltage (Reference)	Vs	Vrms	$790 \pm 10\%$	KD12300 6mA 25°C
4	Surface Brightness	B	$\text{Cd}/\text{m}^2$	$27000 \pm 10\%$	KD12300 6mA 25°C
5	Color Coordinates	x		$0.286 \pm 0.010$	CIE 1931
		y		$0.283 \pm 0.010$	
6	Peak Spectrum (Reference)		Nm	Red	611
				Green	544
				Blue	440
7	Stable Time of Illumination	Ts	min	3min	

### 3.2. Test Conditions

- 3.2.1. Lamp should be placed in horizontal position, under required testing current, and undergo normal lighting for more than 3 minutes, then conduct the electrical and optical properties tests
- 3.2.2. Temperature of Test Environment =  $25^{\circ}\text{C} \pm 2^{\circ}\text{C}$
- 3.2.3. Relative Humidity of Test Environment =  $65\% \pm 20\%$ , under no wind state.

### 3.3. Test Apparatus

Test Items	Test Apparatus
Lamp Voltage	Oscilloscope (Tektronix TDS1012B 100:1)
Lamp Current	Multimeter (Fluke 8086 A)
Surface Brightness	Colorimeter (Topcon BM-7)
Color and Color Temp Coordinates	Colorimeter (Topcon BM-7)

### 3.4. Test Methods

- 3.4.1. CCFL unit under complete voltage control; the test circuit as shown in the Diagram below.
  - 3.4.1.1. LV output end connected to negative of 0V ~ 12V input
  - 3.4.1.2. The connection wire length is 100~300mm
  - 3.4.1.3. Test circuit wires parallel distance should be longer than 100mm in order to avoid possible interference which could affect measurement accuracy
  - 3.4.1.4. When testing current disconnect VL test equipment
  - 3.4.1.5. When testing voltage disconnect IL test equipment
  - 3.4.1.6. During testing, place CCFL unit on shelf with black background in a non-reflective environment

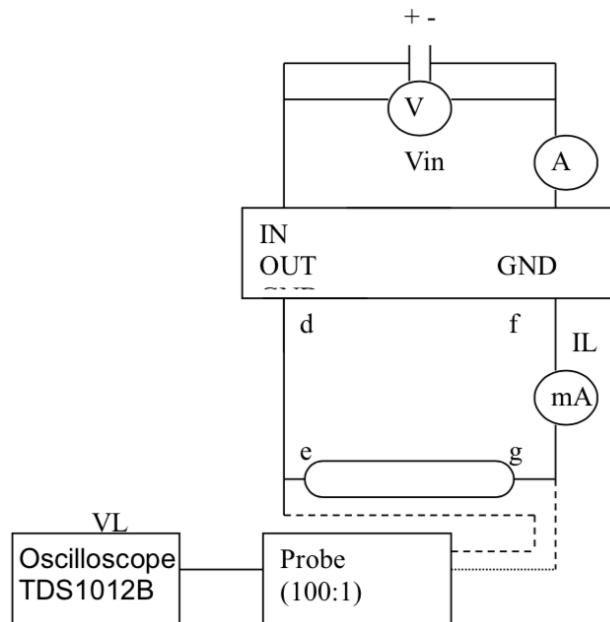

- 3.4.2. Brightness Measurement (naked lamp only), the Colorimeter should be kept a distance of 500 +/- 10mm from the lamp vertical axis and test black perspective at 0.1 degrees.
- 3.4.3. NOTE: testing done with difference test equipment and under different test conditions may result in measurement differences.

#### 4. Drawing

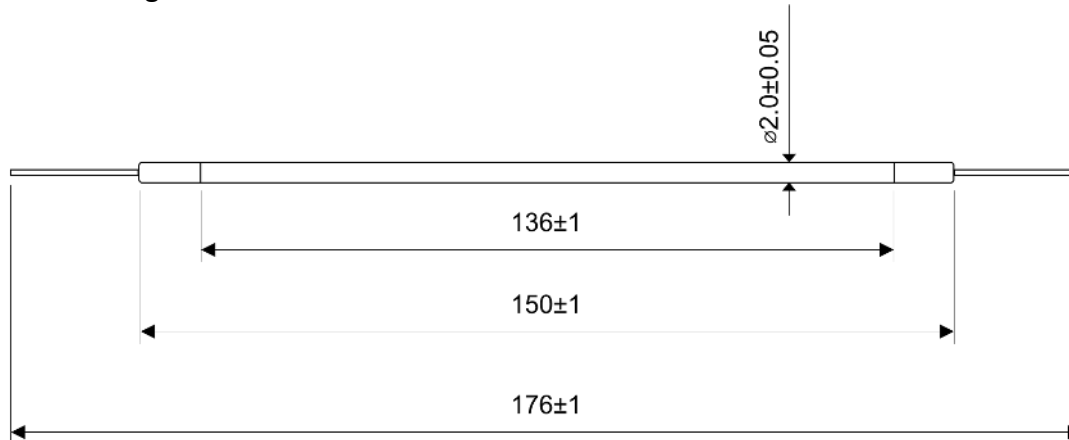

*Not to scale, for illustration purposes only*

#### 5. Notes

- 5.1 These specifications have been tested and approved by Plazmo Industries. Plazmo reserves the right to revise and improve specifications without notice when necessary.
- 5.2 Using an inverter that produced different voltage and current will cause Cold cathode fluorescent lamps (CCFLs) to perform outside of the normal specification. When installing lamps, please pay attention and choose a suitable lamp working current or appropriate input DC voltage, in order to achieve the optimal lighting performance and prevent unnecessary damage.
- 5.3 This CCFL lamp should be driven by power with high frequency and voltage. To avoid poor performance or damage, do not use lamps under listed frequency and voltage.
- 5.4 When the high voltage wire is long, please pay attention that high and low voltage cables do not become intertwined. Keep high voltage and low voltage wires a minimum of 20mm apart whenever possible during testing. Failure to do so may cause interference of recorded values.
- 5.5 Note the lamp current requirements listed in 3.1. Matching this value is critical to ensure proper performance of this CCFL. If the values are not matched by end user's inverter, lamp performance may exhibit low brightness, early failure, and/or other problems.