

DETAIL1
SCALE : 30:1

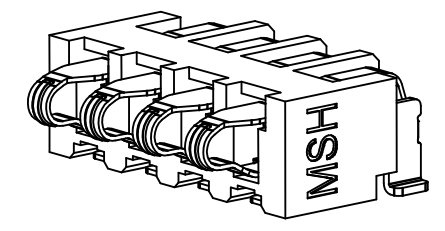

gen1

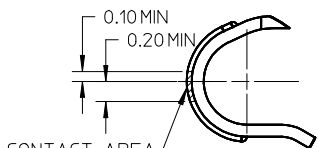

CONTACT AREA
ON DIMPLE
DETAIL2
SCALE : 20:1

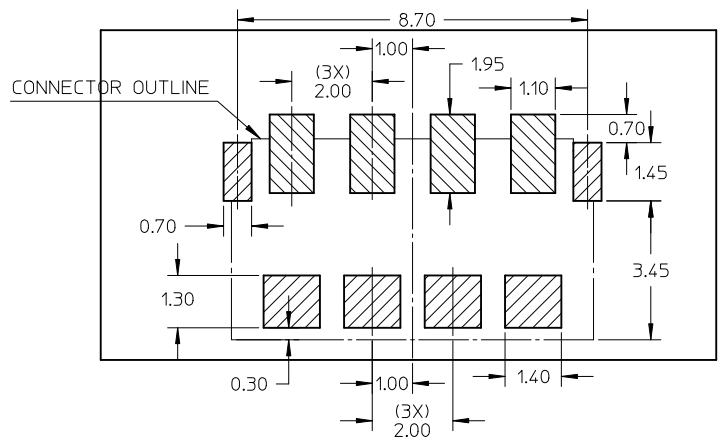
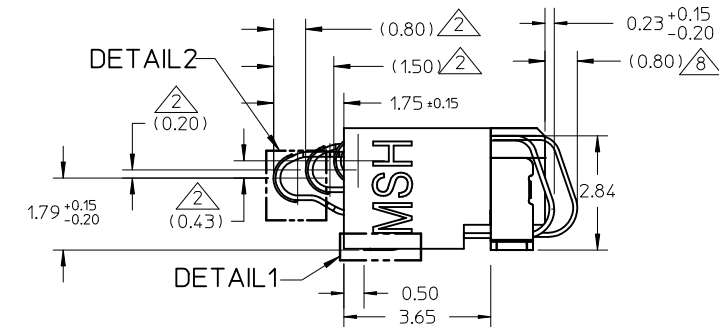
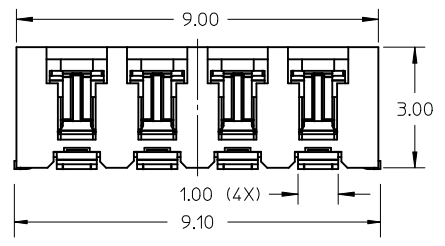

RECOMMENDED PCB LAYOUT
TOLERANCE : ±0.05
(VIEW FROM SURFACE MOUNT SIDE)

1. MATERIALS.
 HOUSING: LIQUID CRYSTAL POLYMER, UL94 V-0. COLOUR BLACK.
 TERMINAL: TITANIUM COPPER, THICKNESS 0.12mm,
 NAIL: COPPER ALLOY , THICKNESS 0.2mm
 TERMINAL PLATING: GOLD FLASH IN SOLDER AREA.
 0.75µm MIN GOLD OVER 1.25µm Min NICKEL IN CONTACT AREA ON DIMPLE.
 NAIL PLATING: 2.0µm MIN TIN.

2. THE RECOMMENDED NOMINAL TRAVEL IS 0.8mm, MAXIMUM TRAVEL IS 1.5mm.

3. 0.08MM COPLANARITY AMONG TERMINAL SOLDER TAILS AND FITTING NAILS.

4. PRODUCT SPECIFICATION PS-105085-001

5. PACKAGING SPECIFICATION PK-105085-001.

6. COMPLIANT TO RoHS DIRECTIVE 2002/95/EC AND ELV DIRECTIVE 2000/53/EC

7. DATE CODE: * * * * (4 DIGITS)

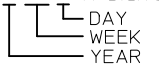

8. AMOUNT OF TERMINAL PROTRUSION WHEN TERMINAL IS AT 1.5mm WORKING HEIGHT.

REV.A RELEASED EC NO: S2011-0348 DRWN:SHONG CHKD:LING APPR:NAGESHKN 2010/10/18 2010/10/27 2010/10/27	QUALITY SYMBOLS ▽=0 ◻=0	GENERAL TOLERANCES (UNLESS SPECIFIED)		DIMENSION STYLE MM ONLY		SCALE 8:1	DESIGN UNITS METRIC	THIRD ANGLE PROJECTION		
		mm	INCH	DRAWN BY	DATE	TITLE				
		4 PLACES ± ---	± ---	JYANG13	2008/12/18	SALES DRAWING 2.0MM PITCH 4 PIN BATTERY CONNECTOR				
		3 PLACES ± ---	± ---	CHECKED BY	DATE					
2 PLACES ± 0.15	± ---	YLZHU02	2008/12/18	MOLEX INCORPORATED						
1 PLACE ± 0.20	± ---	APPROVED BY	DATE							
ANGULAR ± 1 °		MATERIAL NO.		DOCUMENT NO.		SHEET NO.				
DRAFT WHERE APPLICABLE MUST REMAIN WITHIN DIMENSIONS		1050850001		SD-105085-001		1 OF 1				
SIZE A3		THIS DRAWING CONTAINS INFORMATION THAT IS PROPRIETARY TO MOLEX INCORPORATED AND SHOULD NOT BE USED WITHOUT WRITTEN PERMISSION								