

REV.	DATE	ECR NO.	DESCRIPTION
NC	11/20/08	-	INITIAL RELEASE
A	11/23/15	50867	INS MATERIAL WAS BAKELITE, BROWN

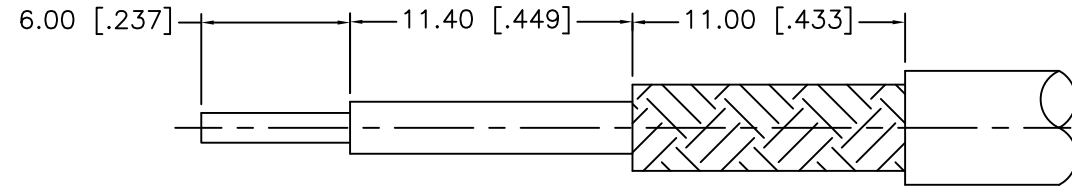

RECOMMENDED CABLE STRIPPING DIM'S

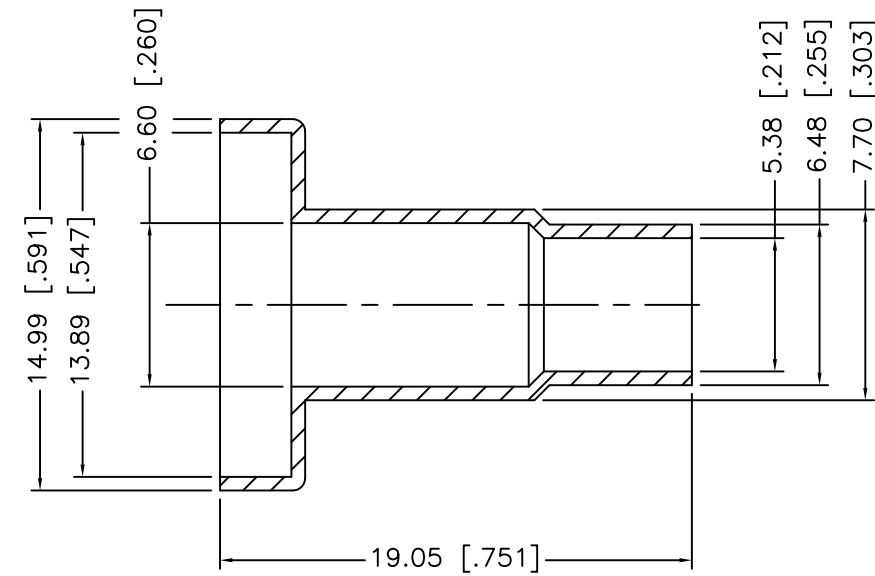
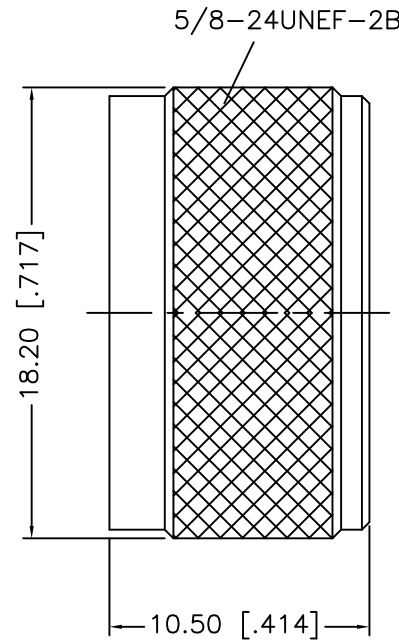
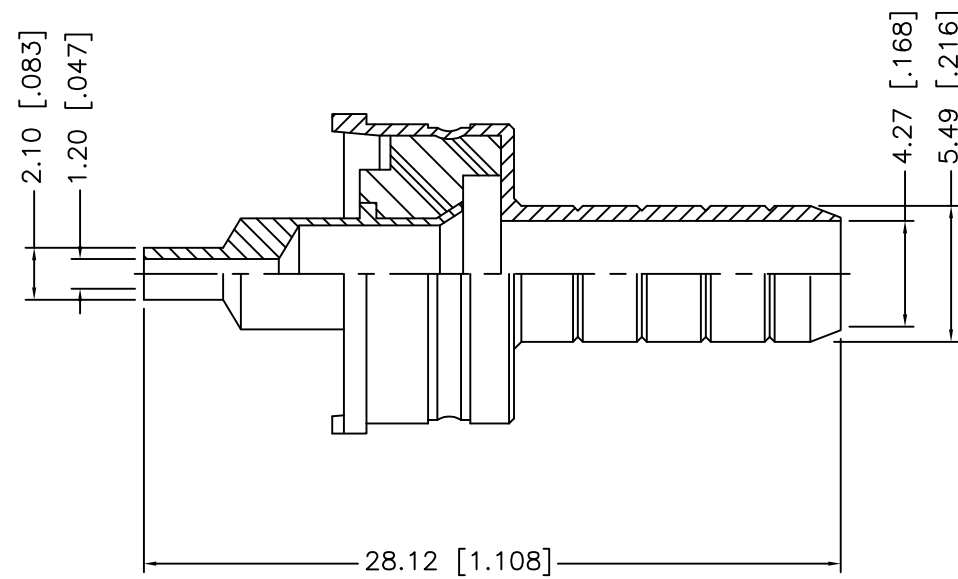

NOTE:

1. CRIMPED FERRULE HEX CRIMP SIZE .255" [6.48].
2. CRIMPED CONTACT PIN HEX CRIMP SIZE .068" [1.73] OR SOLDER.

UNLESS OTHERWISE SPECIFIED DIMENSIONS ARE IN MILLIMETERS. DIMENSIONS IN [ ] ARE IN INCHES AND FOR CUSTOMER REFERENCE ONLY.

UNLESS OTHERWISE SPECIFIED TOLERANCES FOR MILLIMETERS ARE:  
0.5 - 8mm ± 0.20mm  
8 - 30mm ± 0.40mm  
30 - 120mm ± 0.50mm

UNLESS OTHERWISE SPECIFIED TOLERANCES FOR INCHES ARE:  
.020 - .315 = ± 0.007"  
.315 - 1.180 = ± 0.015"  
1.180 - 4.724 = ± 0.020"

DO NOT SCALE DRAWING

APPROVALS	DATE
DRAWN GRS	11/20/08
CHECKED	
ISSUED	
SHEET 1 OF 1	
CAD FILE	
C:/182/182135.DWG	

Amphenol Connex

PART DESCRIPTION

UHF FCP PLUG  
(58/U - DCP TYPE)

PART NO.

182135

DWG. NO.

182135.DWG

REV. A

SIZE A

SCALE NA

DESCRIPTION	MATERIAL	FINISH	QTY
8			
7			
6			
5	FERRULE	BRASS	NICKEL 1
4	CONTACT PIN	BRASS	NICKEL 1
3	INSULATOR	DELFIN	NATURAL 1
2	BODY	BRASS	NICKEL 1
1	SHELL	BRASS	NICKEL 1