

ISS.	AMEND	DATE
1	1st DRAWN	23/06/09
2	UNASSEM VAR ADD	13/05/11
3	VAR UNASSEM ADD	21/09/12

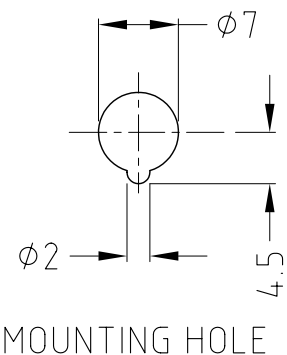
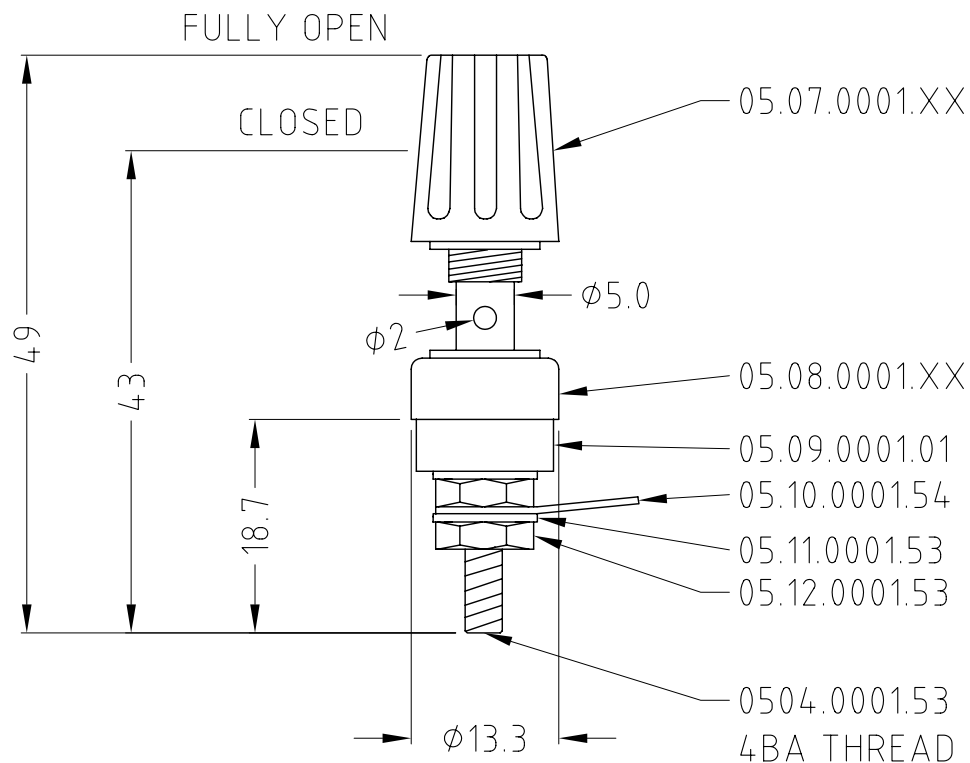

ASSEMBLY NOTES:

- 1) SUPPLIED ASSEMBLED AS SHOWN IS STANDARD.
- 2) 'U' VARIANTS ARE SUPPLIED UNASSEMBLED.
TOP + BOT INSULATORS, NUTS, WASHERS, BULK PACKED.

VARIANTS		COLOURS		
P/No.	MODEL	KNOB	TOP INS	BOT INS
CL1505	TP/1 BLACK	BLACK	BLACK	CLEAR
CL1505U	TP/1 BLACK UNASS	BLACK	BLACK	CLEAR
CL1506	TP/1 RED	RED	RED	CLEAR
CL1506U	TP/1 RED UNASS	RED	RED	CLEAR
CL1507	TP/1 BLUE	BLUE	BLUE	CLEAR
CL1507U	TP/1 BLUE UNASS	BLUE	BLUE	CLEAR
CL1508	TP/1 GREEN	GREEN	GREEN	CLEAR
CL1508U	TP/1 GREEN UNASS	GREEN	GREEN	CLEAR
CL1509	TP/1 WHITE	WHITE	WHITE	CLEAR
CL1509U	TP/1 WHITE UNASS	WHITE	WHITE	CLEAR
CL1511	TP/1 BROWN	BROWN	BROWN	CLEAR
CL1511U	TP/1 BROWN UNASS	BROWN	BROWN	CLEAR
CL1512	TP/1 YELLOW	YELLOW	YELLOW	CLEAR
CL1512U	TP/1 YELLOW UNASS	YELLOW	YELLOW	CLEAR

RoHS
COMPLIANT

TOLERANCE
NO DEC. PLACE ±
1 DEC. PLACE ±
2 DEC. PLACE ±
HOLE Ø ±
ANGLES ±
UNLESS OTHERWISE STATED

DO NOT SCALE

Cliff Electronic Components Ltd.

76 Holmethorpe Avenue, Holmethorpe Industrial Estate,
Redhill, Surrey, RH1 2PF, England, UK
Tel: 01737-771375 Fax: 01737-766012 Website: www.cliffuk.co.uk

THE CONTENTS OF THIS DOCUMENT MUST NOT BE COPIED OR DISCLOSED TO A 3rd PARTY WITHOUT WRITTEN PERMISSION OF CLIFF UK. © 2009

DIMENSIONS IN MILLIMETERS UNLESS OTHERWISE STATED. WORK TO DIMENSIONS. REMOVE ALL BURRS. IF IN DOUBT ASK.

3rd ANGLE PROJECTION:

MATERIAL: POLYPROP / BRASS / POLYAMIDE

FINISH: AS MOULDED / Ag / Ni PLATED

DRAWN: C.A.M.J.

APPROVED: R.W.T.

TITLE: TERMINAL POST TP/1

DRWG. No. **CL1505**

FORM: A4DRWGH