

**STRAIGHT BULKHEAD JACK PANEL SEAL
CLAMP TYPE - CABLE 10+11/50+75 S+D**

R161.332.000
SERIES N

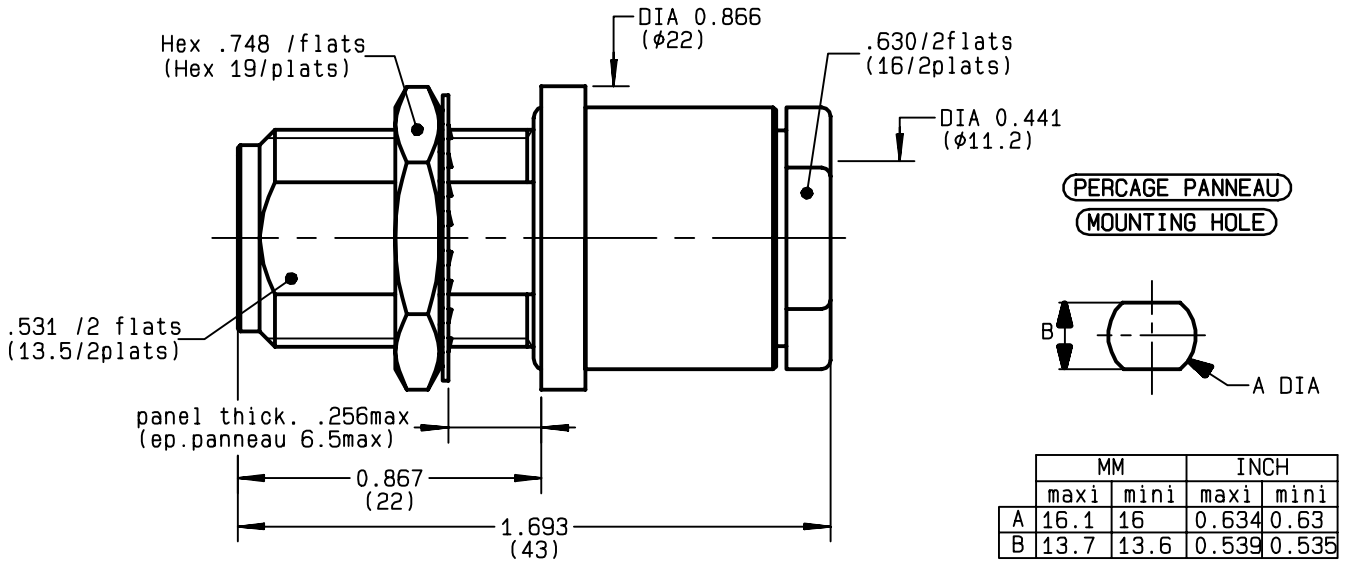

NOMINAL IMPEDANCE	50	Ω
FREQUENCY RANGE	0-11	GHz
TEMPERATURE RATING	-55/+155	$^{\circ}$ C
V.S.W.R	1.30 +	x F(GHz)Maxi
RF INSERTION LOSS	0.048	\sqrt{F} (GHz) dB Maxi
VOLTAGE RATING	1400	Veff Maxi
DIELECTRIC WITHSTANDING VOLTAGE	2500	Veff Mini
INSULATION RESISTANCE	5000	M Ω Mini
HERMETIC SEAL	NA	Atm.cm ³ /s
LEAKAGE (pressurized only)	IP 67	
MECHANICAL DURABILITY	500	Cycles
WEIGHT	54.5	gr
SPECIFICATION		

- CABLES : **KX 4**
KX 8
RG 11
RG 144
RG 165
RG 213
RG 214
RG 216
RG 225
RG 393

OTHERS CHARACTERISTICS

CABLE RETENTION	300	N Mini
CENTER CONTACT RETENTION		
Axial force - mating end	NA	N Mini
Axial force - opposite end	NA	N Mini
Torque	NA	cm.N Mini
RECOMMENDED TORQUES		
Mating	NA	cm.N
Panel nut	500	cm.N
Clamp nut	800	cm.N

CONNECTOR PARTS	MATERIALS	FINISH	(all values are given in micrometers)
BODY	BRASS	BBR 2	
OUTER CONTACT	BRASS	BBR 2	
CENTER CONTACT	BERYLLIUM COPPER	GOLD 0.5 OVER NICKEL 2	
INSULATOR	PTFE	-	
GASKET	SILICONE RUBBER	-	
OTHERS PIECES	BRASS	BBR 2	

BONMINI

ISSUE	CREATION DATE	FILE PART-NUMBER
9726R04	09/11/1992	



The information given here is subject to change without notice.
Design changes may be in order to improve the product.

Connect to the future



R161.332.000

ISSUE **9726R04** SERIES **N**

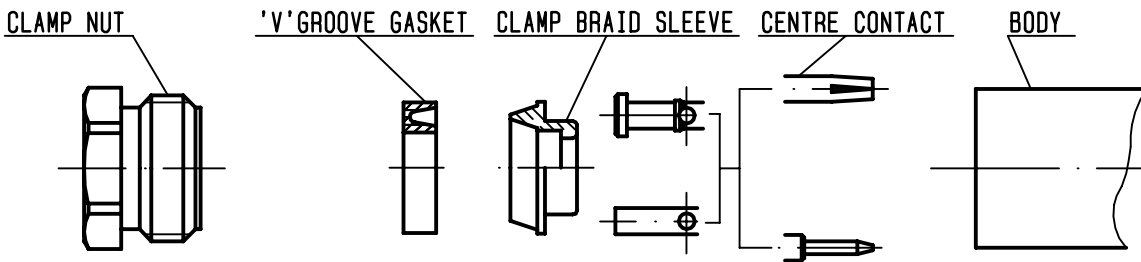

①

Strip the cable .
-
-
-

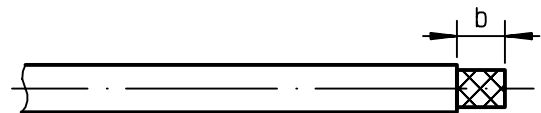

Stripping	a	b	c	d	e
inch	0.197	0.335	0	0	0.059
mm	5	8.5			1.5

②

Slide the clamp nut and the 'V' groove gasket onto the cable .
Slide clamp braid sleeve over braid .
Fold back braid and trim off surplus braid .
Trim back dielectric as shown .
-

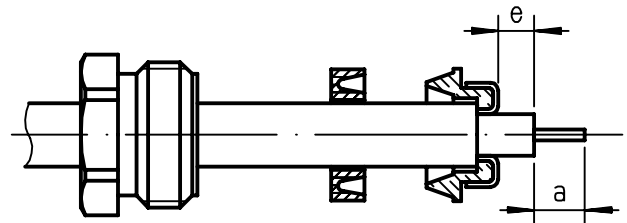

③

Solder the cable inner conductor into centre contact .
-
-
-

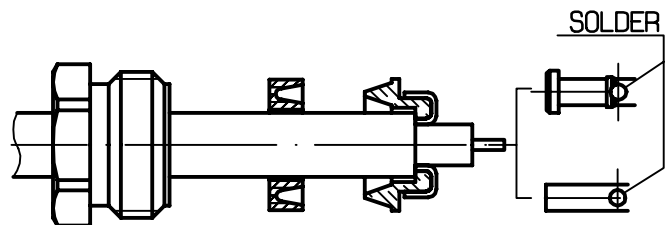

④

Screw sub-assembly into the connector body .
(recommended coupling torque 70.8 in.lb)
-
-

