

PART NAME: KNOB

SCALE: 1:1

DATE: 8/13/09

DR. BY JAM

DAVIES MOLDING COMPANY
CAROL STREAM, ILLINOIS 60188

P/N 1507-D

THIS DRAWING IS THE PROPERTY OF DAVIES MOLDING COMPANY, IS SUBMITTED SOLELY AS A DESIGN OR ENGINEERING PROJECT.
WE ACCEPT NO RESPONSIBILITY WHATSOEVER FOR THE PRACTICAL APPLICATION OF THE PIECES MADE TO THIS DESIGN.

MOLD #	1507
CAVITY	1507
CORE	1507
PIN	1507-D

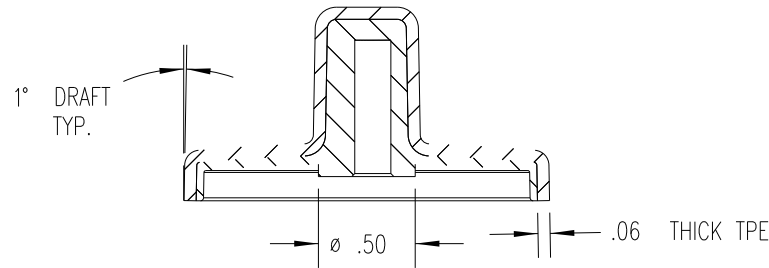
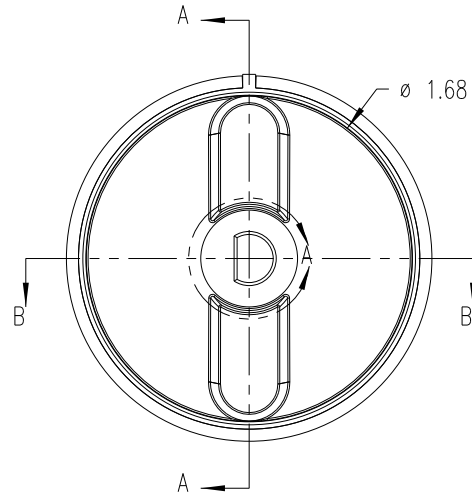
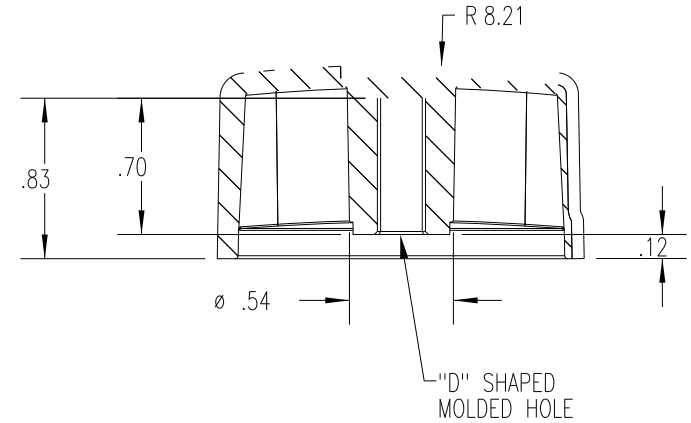
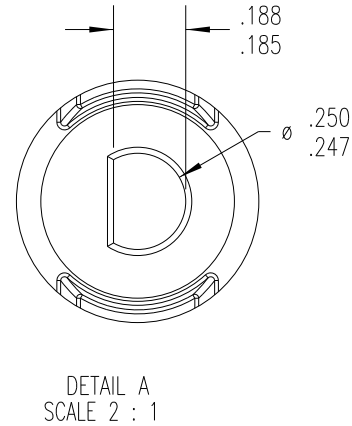
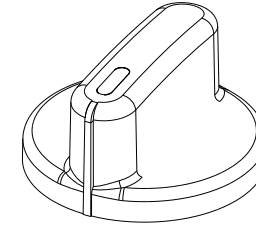
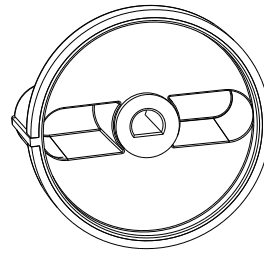
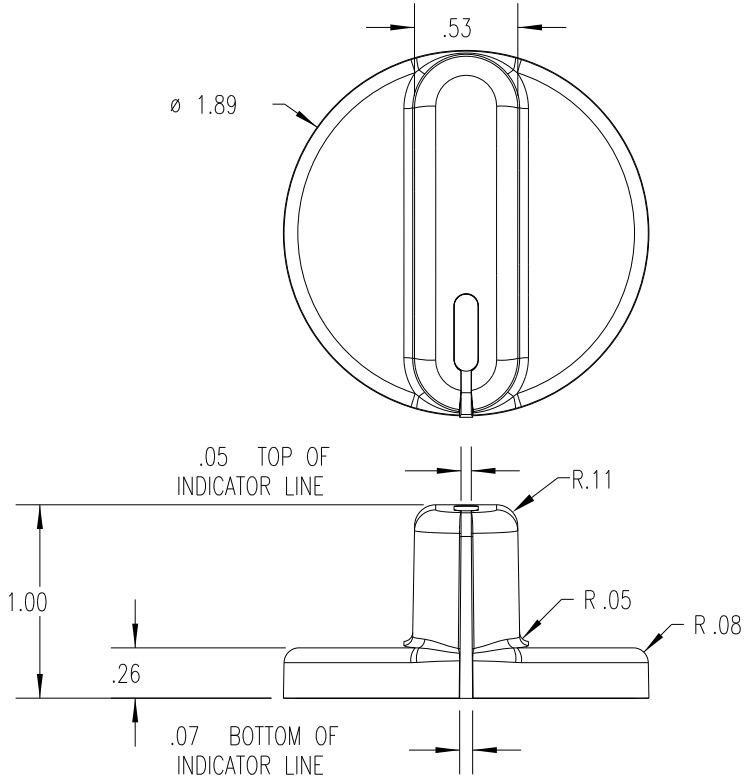

SECTION A-A

SECTION B-B

SUBSTRATE MATERIAL: NYLON 6/6 (CLC)
 COLOR: WHITE (PC23083)
 OVERMOLD MATERIAL: NYLON 6/6 (CLC)
 COLOR: RED (NC301100)

TOLERANCES: UNLESS OTHERWISE SPECIFIED	DO NOT SCALE DRAWING			
DECIMALS: X.XXX ± .005 X.XX ± .015	MM: X.XX ± 0.15MM X.X ± 0.4MM	-	WAS SK1507-11	JAM 8/13/09
FRACTIONS ± 1/64	ANG. ± 1°	CHANGES		