

Product Data Sheet

3M™ Active Optical Cable (AOC) Assemblies for QSFP+ to 4x SFP+ Fan-out Applications



3M Electronic Solutions Division

6801 River Place Blvd.

Austin, TX 78726-9000

www.3Mconnectors.com



Table of Contents

1.0	Description.....	2
2.0	Absolute Maximum Rating for QSFP+ and SFP+ Modules.....	2
3.0	Recommended Operating Conditions for QSFP+ and SFP+ Modules.....	2
4.0	QSFP+ Module Electrical Characteristics per 40GBase-SR4.....	3
5.0	SFP+ Module Electrical Characteristics per SFF-8431.....	3
6.0	QSFP+ Pad Layout.....	5
7.0	SFP+ Pad Layout.....	5
8.0	Low Speed Electrical Control Line Description of QSFP+ modules.....	6
9.0	Low Speed Electrical Control Line Description of SFP+ modules.....	6
10.0	Mechanical Characteristics.....	7
11.0	Link Performance.....	7
12.0	Standards and Regulatory.....	7
13.0	Functional Performance Criteria.....	7
14.0	Break-Out Assembly Tests.....	8
15.0	Physical dimensions.....	8
16.0	Laser safety warning.....	8

1.0 Description

In high-performance networking environments it is sometimes important to connect between different connector types. 3M's new Active Optical Cable (AOC) Assembly for QSFP+ and SFP+ Applications allows connections between a four channel QSFP+ port and four separate SFP+ ports, enabling a new level of flexibility for AOC applications. The AOC transmits four parallel channels each operating up to 10.5 Gbps. Using industry leading VCSEL technology and an advanced light-engine design, the 3M AOC assembly provides exceptional cost/performance value.

Features

- Low power
- Four channels each operating up to 10.5 Gbps with 8b/10b compatible data
- Fiber link up to 100m
- Reliable 850nm VCSEL technology
- 0 to +70 degree Celsius operating temperature range
- Hot pluggable
- Bend insensitive fiber
- Full set of diagnostic features as per SFF-8472
- Designed to meet SFF-8436, SFF-8431 and SFF-8432 specifications
- Fan-out assembly designed to meet GR-2866-CORE – “Telcordia Generic Requirement for Optical Fiber Ribbon Fan-outs”

2.0 Absolute Maximum Rating

Parameters	Min	Max	Units
Storage temperature	-40	+85	Deg. Celsius
Relative humidity	5	85	%
Supply voltage	3.10	+3.65	V
Operating case temperature	0	+70	Deg. Celsius

Note: if product is exposed to conditions beyond the levels indicated, the reliability of the product is likely to be negatively affected.

3.0 Recommended Operating Conditions for QSFP+ and SFP+ Modules

Parameter	Min	Typ	Max	Units
Supply voltage Vcc	3.135	3.3	3.465	V
Power dissipation for QSFP+		700		mW
Power dissipation for SFP+		250		mW
Operating case temperature for both QSFP+ and SFP+ modules	0		+70	Degree Celsius
Signaling rate/channel, NRZ			10.5	Gbit/s

4.0 QSFP+ Module Electrical Characteristics per 40GBase-SR4

QSFP+ Input electrical characteristics per lane				
Parameters	Min	Typ	Max	Units
Single-ended input voltage tolerance	-0.3		4.0	V
Transmitter differential input voltage, peak-to-peak	120		1200	mV
J ₂ – Jitter tolerance	0.17			UI (note 1)
J ₉ – Jitter tolerance	0.29			UI
SDD ₁₁ -Differential input return loss	(note 2)			dB
SCD ₁₁ –Differential to common-mode input return loss	(note 3)			dB
QSFP+ Output electrical characteristics per lane				
Single-ended output voltage	-0.3		4.0	V
Receiver differential output voltage peak-to-peak		422		mV (with pre-emphasis)
J ₂ Jitter output			0.42	UI
J ₉ Jitter output			0.65	UI
SDD ₂₂ - Differential output return loss	(note 2)			dB
SCC ₂₂ – Common-mode output return loss	(note 4)			dB
Link bit error rate (BER)		<10E-12		Bit
Eye mask parameter, time X1, X2		0.29, 0.5		UI (note 5)
Differential unsigned output Voltage Y1, Y2		150, 425		mV (note 5)

- Notes:**
1. UI for 10GbE is ~97ps.
 2. SDD₁₁ /SDD₂₂ differential return loss is measured at TP1 and TP4 as:
 { 12- 2 SQRT(f), 0.01 ≤ f < 4.11 6.3 - 13log(f/5.5), 4.11 ≤ f ≤ 11.1 } f is frequency in GHz.
 3. SCD₁₁ measured at TP1 > 10 dB { 10Mhz to 11.1GHz}
 4. SCC₂₂ – Common-mode output return loss at TP4 is defined as:
 { 7-1.6f 0.01≤f < 2.5, 3 2.5≤f ≤ 11.1 } f is the frequency in GHz
 5. Mask hit ratio of 5x10⁻⁵

5.0 SFP+ Module Electrical Characteristics per SFF-8431

SFP+ Input electrical characteristics per module				
Parameters	Min	Typ	Max	Units
Single-ended input voltage tolerance	-0.3		4.0	V
Signaling rate/channel, NRZ			10.5	Gbit/s
DDJ –data dependent jitter		0.10		UI(p-p)
TJ- total jitter			0.28	UI(p-p)
DDPWS –pulse width shrinkage jitter		0.055		UI(p-p)
SDD ₁₁ – differential input return loss	(note 1)			dB
SCD ₁₁ - reflected differential to common mode input return loss	(note 2)			dB
Eye mask coordinates {X1, X2, Y1, Y2}		0.12, 0.33, 95, 350		UI mV (note 4)
SFP+ Output electrical characteristics per module				
Single-ended output voltage tolerance	-0.3		4	V
AC common mode output voltage			7.5	mV rms
J ₂ Jitter			0.42	UI(p-p)

TJ- total Jitter			0.70	UI(p-p)
Output rise and fall times	28			ps (20 to 80%)
SDD ₂₂ – differential output return loss	(note 1)			
SCC ₂₂ – Common-mode output return loss	(note 3)			dB
Link bit error rate (BER)	<10E-12			bit
Eye mask coordinates {X1, Y1, Y2}	0.35, 150, 425			UI mV (note 4)

- Notes:**
- SDD_{11/22} differential input and output return loss is defined as:**
 { 12-2 SQRT(f), 1.0 ≤ f < 4.11 6.3-13log(f/5.5), 4.11 ≤ f ≤ 11.1GHz }
 f is frequency in Ghz
 SCD₁₁ measured at TP1 > 10 dB { 10Mhz to 11.1GHz }
 - SCC₂₂ – Common-mode output return loss at TP4 is defined as:**
 { 7-1.6f 0.01 ≤ f < 2.5, 3 2.5 ≤ f ≤ 11.1 }
 f is the frequency in GHz
 - Receiver output Eye Mask is measured with a hit ratio of 5E-5 with a 100 Ohm load.**

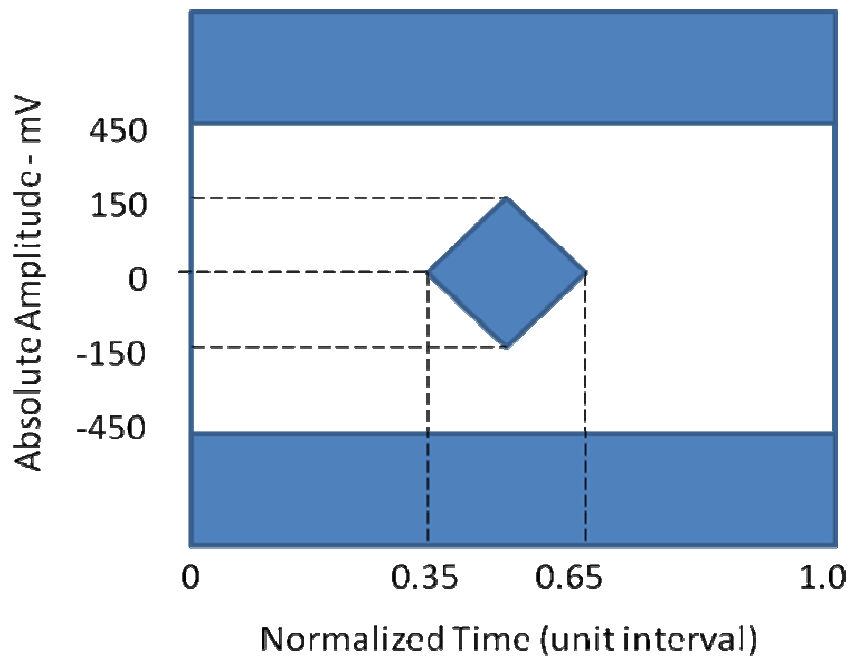

Receiver Electrical output Eye Msask definition for SFP+ module

6.0 QSFP+ Pad Layout

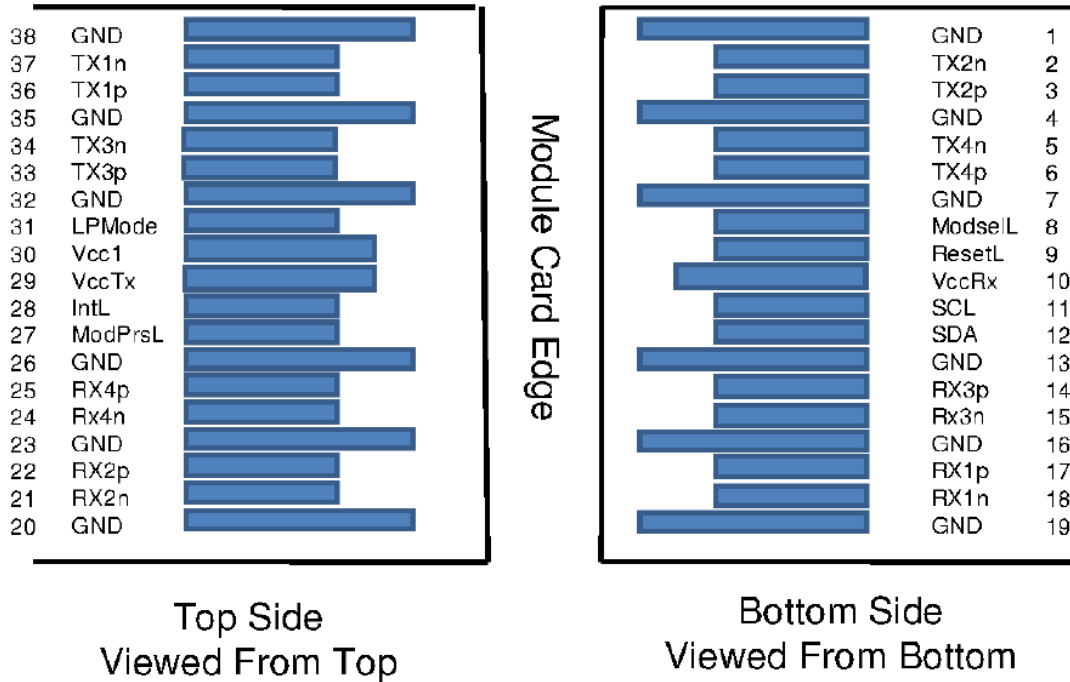

7.0 SFP+ Pad Layout

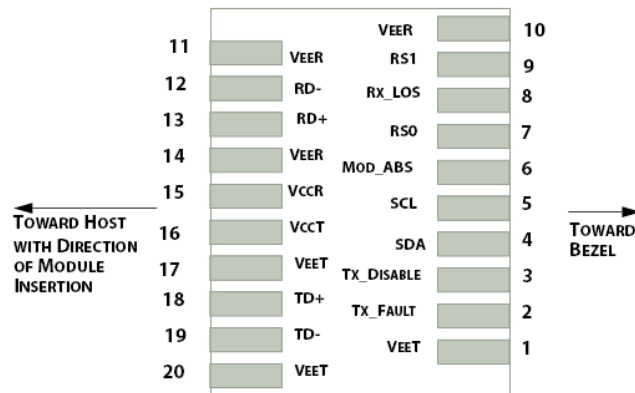

8.0 Low Speed Electrical Control Line Description of QSFP+ modules

ModSelL

The ModSelL is an input pin that the host holds “low” when it needs to communication with the module over the I2C interface. It is pulled “high” inside the QSFP+ module.

ResetL

The ResetL pin is normally pulled “high” in the module. The host pulls this “low” to initiate a module reset, returning all user modules settings to their default values.

LPMODE

The QSFP+ module can have two power consumption modes: a low power mode and a high power mode. The 3M module for QSFP+ applications operates in the low power mode class, which means the power consumption cannot exceed 1.5W.

ModPrsL

ModPrsL is used by the host to detect when a module is inserted into the appropriate port. This pin is grounded in the module and pulled “high” by the host.

IntL

This is an output pin and when asserted “low” it indicates a possible fault in the module which the host system is alerted to. The host system then can interrogate the module via the 2-wire interface to determine the cause of the fault.

9.0 Low Speed Electrical Control Line Description of SFP+ modules

Transmitter Fault (Tx_Fault)

Transmitter fault detection is not supported, the “TX-Fault” line is ground inside the module.

Transmitter Disable (Tx_Disable)

This is an input line to the module allowing the host to disable the VCSEL driver, switching off the transmitter. The line is pulled high with a pull-up resistor inside the module. When this pin is asserted low or grounded the VCSEL driver operates normally

RS0/RS1 (not supported)

These are optional input lines to the module to allow the host to select the rate of the module.

MOD_ABS (MOD_DEFO)

This line is used to detect the absence or presence of the module by the host. This line is connected to a ground inside the module. The host may pull this line up to Vcc with a resistor and asserted high to detect the absence of the module.

SCL/SDA

A complete memory map is support via the I2C interface.

Receiver Loss of Signal (Rx_LOS)

This line represents the receiver signal strength detection signal and is an output line. When the optical signal strength falls below a certain threshold, the module asserts this line high.

10.0 Mechanical Characteristics

Parameters	Min	Typ	Max	Units
Cable Installation Tension			45	N
Cable Operating Tension			31	N
Operating Cable Bend Radius	3			cm
Installation Cable Bend Radius	6			cm
Cable Outer Diameter	2.85	3.0	3.15	mm

11.0 Link Performance

This AOC uses advance OM2+ multimode fiber with overfilled modal bandwidth of >700Mhz.Km and effective modal bandwidth of >950MHz.km at wavelength of 850nm. This allows excellent link performance up to 100 meters of 10GB Ethernet operation.

12.0 Standards and Regulatory

The QSFP AOC has been designed and tested in accordance with the following reliability and regulatory specifications:

- Physical, Electrical and Digital Management Interface designed to meet SFF-8436, SFF-8431, SFF-8472 and SFF-8432
- Supports IEEE Std 802.3ab-2008, Annex 86, Parallel Physical Interface (nPPI) for 40GBASE-SR4
- Product tested according to Telcordia GR-468-CORE Generic Reliability Assurance Requirements for Optoelectronics Devices
- Restriction on Hazardous Substances (RoHS) per EU requirements (ROHS directive 2011/65/EU)
- Class 1M Eye safe per IEC 60825-1/CDRH
- NEC Article 770 for type OFNP/CSA FT6 Cable Rating
- FCC Class B and CE Emissions and Immunity requirements
- UL 94 V0 Flammability for plastic parts strain relief and pull tab
- EN61000-4-2 (15KV air discharge during operation, and 8KV direct contact discharges to the case)
- Human Body Model per JEDEC JESD22-A114-B

13.0 Functional Performance Criteria

The QSFP+ and SFP+ modules are tested in accordance with various EIA and MIL-STDs specified below. Sample sizes were selected in accordance with individual test criteria. Unless otherwise specified, all values and limits are typical of those obtained by qualification testing of the subject product.

	Test	Reference	Results
1	High Temperature Operating Life	Section 5.18 (GR-468-CORE)	Pass
2	Biased Damp Heat	MIL-STD-202 Method 103	Pass
3	Temperature Cycling	MIL-STD-883 Method 1010	Pass
4	Biased Cyclic Moisture Resistance	MIL-STD-883 Method 1004	Pass
5	Thermal Shock	MIL-STD-883 Method 1011.9	Pass
6a	Mechanical Shock (MS)	MIL-STD-883 Method 2002B	Pass
6b	Mechanical Vibration (MV)	MIL-STD-883 Method 2007	Pass
7a	ESD - HBM	JESD22-A114-B	Pass
7b	ESD air discharge	EN61000-4-2	Pass

7c	ESD Contact discharge	EN61000-4-2	Pass
8a	Durability	EIA-364-09C.	Pass
9a	Insertion Force	EIA/ECA-36413D.	Pass
9b	Withdrawal Force	EIA/ECA-36413D.	Pass
9c	Retention Force	TIA-455-6-B, FOTP 6	Pass
10	Impact test	TIA-455-2C, FOTP-2	Pass

14.0 Break-Out Assembly Tests

The break-out assembly is tested separately for mechanical and environment integrity and underwent the following tests:

	Test	Reference	Results
1	Temperature cycling	MIL-STD-202 Method 103	Pass
2	Retention Force	TIA-455-6-B, FOTP-6	Pass

15.0 Physical dimensions

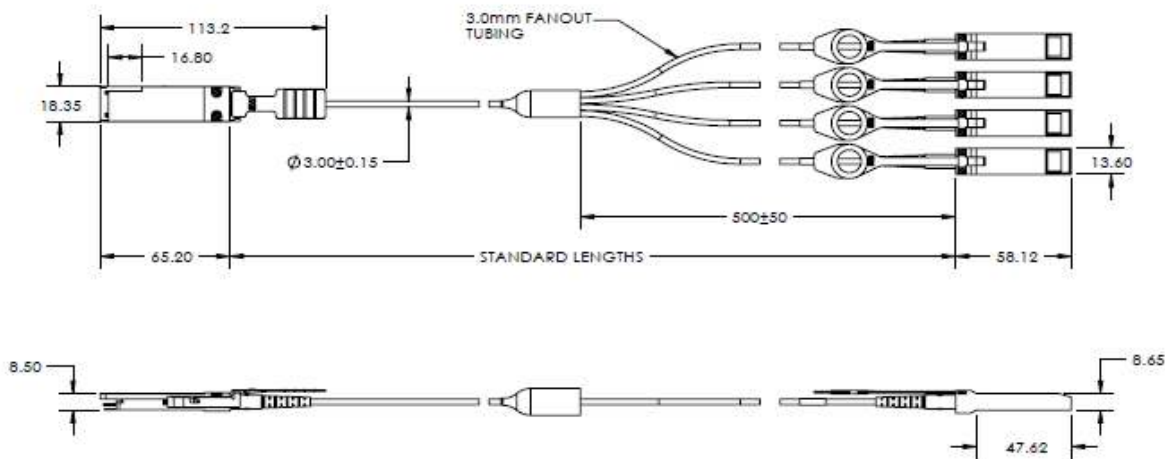

Refer to 3M Drawing 78-5100-2576-6 for more information

16.0 Laser safety warning

**INVISIBLE LASER RADIATION
 CLASS 1M LASER PRODUCT**

**DO NOT VIEW THE END OF OPTICAL FIBER WITH OPTICAL INSTRUMENTS AS THIS MAY
 RESULT IN HAZARDOUS RADIATION EXPOSURE (i.e. FIBER OPTIC VIEWERS, HAND-HELD
 MAGNIFIERS OR BINOCULARS OR OTHER DIRECT IMAGING DEVICES)**

Unless otherwise noted, references to industry specifications are intended to indicate substantial compliance to the material elements of the specification. Such references should not be construed as a guarantee of compliance to all requirements in a given specification.

"RoHS 2011/65/EU" means that the product or part does not contain any of the substances in excess of the maximum concentration values ("MCVs") in EU RoHS Directive 2011/65/EU. The MCVs are by weight in homogeneous materials. This information represents 3M's knowledge and belief, which may be based in whole or in part on information provided by third party suppliers to 3M.

In the event any product is proven not to conform with 3M's Regulatory Information Appendix, then 3M's entire liability and Buyer's exclusive remedy will be in accordance with the Warranty stated below.

3M is a trademark of 3M Company.

Important Notice

All statements, technical information, and recommendations related to 3M's products are based on information believed to be reliable, but the accuracy or completeness is not guaranteed. Before using this product, you must evaluate it and determine if it is suitable for your intended application. You assume all risks and liability associated with such use. Any statements related to the product which are not contained in 3M's current publications, or any contrary statements contained on your purchase order shall have no force or effect unless expressly agreed upon, in writing, by an authorized officer of 3M.

Warranty; Limited Remedy; Limited Liability.

This product will be free from defects in material and manufacture for a period of 2 years from the time of purchase. 3M MAKES NO OTHER WARRANTIES INCLUDING, BUT NOT LIMITED TO, ANY IMPLIED WARRANTY OF MERCHANTABILITY OR FITNESS FOR A PARTICULAR PURPOSE. If this product is defective within the warranty period stated above, your exclusive remedy shall be, at 3M's option, to replace or repair the 3M product or refund the purchase price of the 3M product. Except where prohibited by law, 3M will not be liable for any indirect, special, incidental or consequential loss or damage arising from this 3M product, regardless of the legal theory asserted.