

QTY. OF CIRC. "XX"	DIM. "A"	DIM. "B"	DIM. "C"	DIM. "D"	MATERIAL # (-50 OPT.)
02	25.1 (1.99)	6.35 (1.250)	19.05 (1.750)	14.4 (1.57)	38600-7602
03	31.5 (1.24)	12.70 (1.500)	25.40 (1.000)	20.8 (1.82)	38600-7603
04	37.8 (1.49)	19.05 (1.750)	31.75 (1.250)	27.1 (1.07)	38600-7604
05	44.2 (1.74)	25.40 (1.000)	38.10 (1.500)	33.5 (1.32)	38600-7605
06	50.5 (1.99)	31.75 (1.250)	44.45 (1.750)	39.8 (1.57)	38600-7606
07	56.9 (2.24)	38.10 (1.500)	50.80 (2.000)	46.2 (1.82)	38600-7607
08	63.2 (2.49)	44.45 (1.750)	57.15 (2.250)	52.5 (2.07)	38600-7608
09	69.6 (2.74)	50.80 (2.000)	63.50 (2.500)	58.9 (2.32)	38600-7609
10	75.9 (2.99)	57.15 (2.250)	69.85 (2.750)	65.2 (2.57)	38600-7610
11	82.3 (3.24)	63.50 (2.500)	76.20 (3.000)	71.6 (2.82)	38600-7611
12	88.6 (3.49)	69.85 (2.750)	82.55 (3.250)	77.9 (3.07)	38600-7612
13	95.0 (3.74)	76.20 (3.000)	88.90 (3.500)	84.3 (3.32)	38600-7613
14	101.3 (3.99)	82.55 (3.250)	95.25 (3.750)	90.6 (3.57)	38600-7614
15	107.7 (4.24)	88.90 (3.500)	101.60 (4.000)	97.0 (3.82)	38600-7615
16	114.0 (4.49)	95.25 (3.750)	107.95 (4.250)	103.3 (4.07)	38600-7616
17	120.4 (4.74)	101.60 (4.000)	114.30 (4.500)	109.7 (4.32)	38600-7617
18	126.7 (4.99)	107.95 (4.250)	120.65 (4.750)	116.0 (4.57)	38600-7618
19	133.1 (5.24)	114.30 (4.500)	127.00 (5.000)	122.4 (4.82)	38600-7619
20	139.4 (5.49)	120.65 (4.750)	133.35 (5.250)	128.7 (5.07)	38600-7620
21	145.8 (5.74)	127.00 (5.000)	139.70 (5.500)	135.1 (5.32)	38600-7621
22	152.1 (5.99)	133.35 (5.250)	146.05 (5.750)	141.4 (5.57)	38600-7622
23	158.5 (6.24)	139.70 (5.500)	152.40 (6.000)	147.8 (5.82)	38600-7623
24	164.8 (6.49)	146.05 (5.750)	158.75 (6.250)	154.1 (6.07)	38600-7624
25	171.2 (6.74)	152.40 (6.000)	165.10 (6.500)	160.5 (6.32)	38600-7625
26	177.5 (6.99)	158.75 (6.250)	171.45 (6.750)	166.8 (6.57)	38600-7626
27	183.9 (7.24)	165.10 (6.500)	177.80 (7.000)	173.2 (6.82)	38600-7627
28	190.2 (7.49)	171.45 (6.750)	184.15 (7.250)	179.5 (7.07)	38600-7628
29	196.6 (7.74)	177.80 (7.000)	190.50 (7.500)	185.9 (7.32)	38600-7629
30	202.9 (7.99)	184.15 (7.250)	196.85 (7.750)	192.2 (7.57)	38600-7630
31	209.3 (8.24)	190.50 (7.500)	203.20 (8.000)	198.6 (7.82)	38600-7631
32	215.6 (8.49)	196.85 (7.750)	209.55 (8.250)	204.9 (8.07)	38600-7632

- NOTES:
1. MATERIAL: SEE TABLE
 2. FINISHES: SEE TABLE
 3. PRODUCT SPECIFICATION: NOT REQUIRED
 4. PACKAGING: NOT REQUIRED
 5. MATES WITH: NONE
 6. "XX" REFERS TO THE QUANTITY OF CIRCUITS.

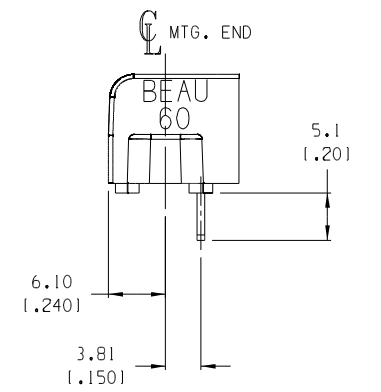
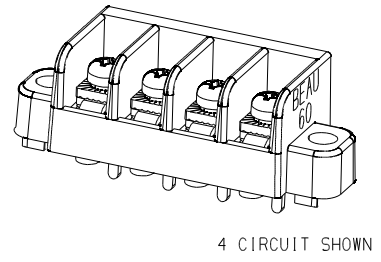
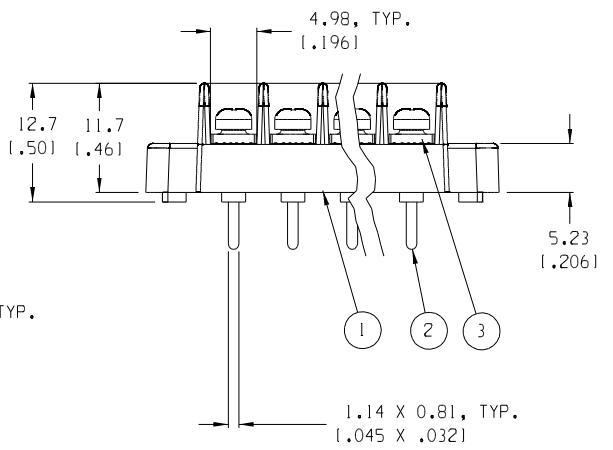
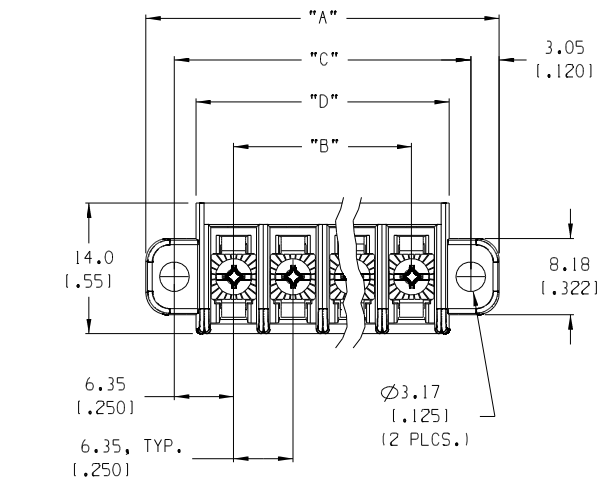
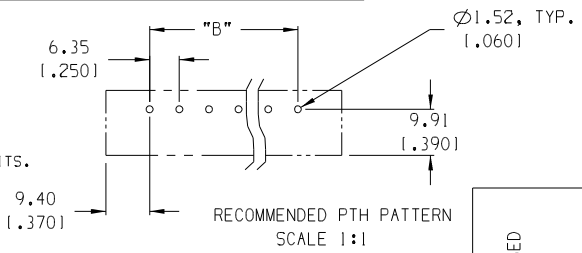

ITEM	QTY.	DESCRIPTION	MATERIAL	FINISH
3	XX	SCREW, #3-48, PHIL-SLOT, SQ WASHER (-50 OPT.)	STEEL	ZN, CLEAR CHROMATE
2	XX	TERMINAL, PC	BRASS	TIN PLATE
1	1	INSULATOR, SR, CLOSED SIDE	BLACK	THERMOPLASTIC

EC NO. RELEASED CLY DRWN: CH*KT APPR:	QUALITY SYMBOLS MAJOR CRITICAL SPC S	GENERAL TOLERANCES: (UNLESS SPECIFIED)		SCALE 2:1	DESIGN UNITS <input type="checkbox"/> mm <input checked="" type="checkbox"/> INCH	THIRD ANGLE PROJECTION	PROJECT NO. - DIMENSIONS:		SHT REV
		mm INCH 4 PLACES ±.0015 3 PLACES ±.038 ±.005 2 PLACES ±.13 ±.01 1 PLACE ±.3	DRAWN BY & DATE C. YORK 11-22-04	TITLE: 6.35mm (.250") SR BTS ASSY, CLOSED SIDE, CLAMP WASHER SCREW		MATERIAL NO. SEE CHART		DRAWING NO. SD-38600-003	
DRAFT WHERE APPLICABLE MUST REMAIN WITHIN DIMENSIONS		ANGULAR: ±2°		CAD FILENAME 605XX		THIS DRAWING CONTAINS INFORMATION THAT IS PROPRIETARY TO MOLEX INCORPORATED AND SHOULD NOT BE USED WITHOUT WRITTEN PERMISSION.		SIZE B	