

LOC	DIST	REV	DATE	BY	APP'D
AD	00	0	30SEP2004	BC	RW
		A	10JUL2006	DH	DB

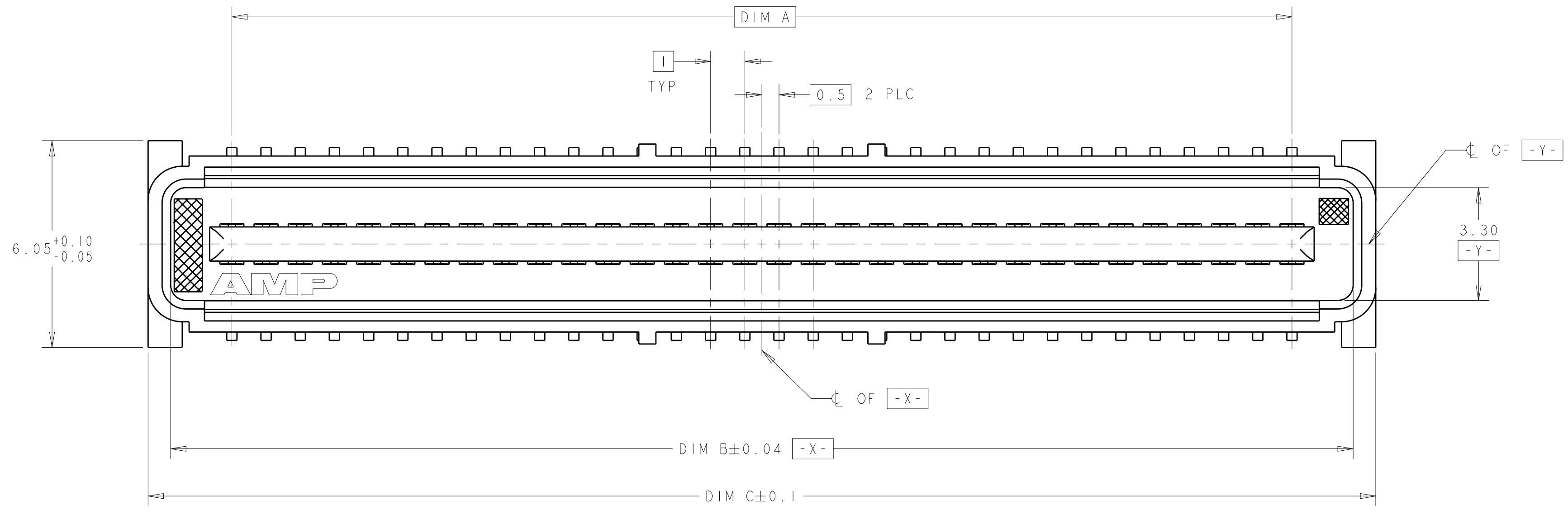

- 1. HOUSING MATERIAL: LIQUID CRYSTAL POLYMER COLOR: BLACK. CONTACT MATERIAL: PHOSPHOR BRONZE.
- 2. CONTACT FINISH: NICKEL UNDERPLATE ALL OVER, MATING SURFACES PLATED TO MEET PLI PERFORMANCE REQUIREMENTS OF INDUSTRY SPECIFICATION EIA-700AAAB, SOLDER TAILS PLATED TIN.
- 3. DATUM LOCATIONS AND BASIC DIMENSIONS TO BE ESTABLISHED BY THE CUSTOMER. CONSULT AMP ENGINEERING WHEN PLACING MULTIPLE CONNECTORS ON A PC BOARD.
- 4. PACKAGED IN TAPE ON REEL PER EIA-481.
- 5. VACUUM COVER DESIGNED FOR 4mm DIA. NOZZLE. VACUUM COVER TO BE REMOVED AFTER SOLDERING. VACUUM COVER REMOVED FROM SOME VIEWS FOR DIMENSIONAL CLARITY.
- 6. SHORTER SOLDER LANDS MAY BE USED PER EIA 700AAAB, HOWEVER 2.7 LENGTH ASSURES OPTIMUM SOLDER FILLET REGARDLESS OF MANUFACTURER OF CONNECTOR.
- 7. REFERRED TO AS DIM N IN EIA 700AAAB SPECIFICATION.
- 8. 5.5 MIN DIAMETER TARGET AREA FOR VACUUM PICK-UP.
- 9. CONTACT FINISH: 0.00381 MINIMUM MATTE TIN PER ASTM B 545 ON SOLDER AREA, 0.00127 MINIMUM GOLD PER ASTM B 488 ON MATING AREA, BOTH OVER 0.00127 MINIMUM NICKEL PER SAE-AMS-QQ-N-290 ON ENTIRE CONTACT.

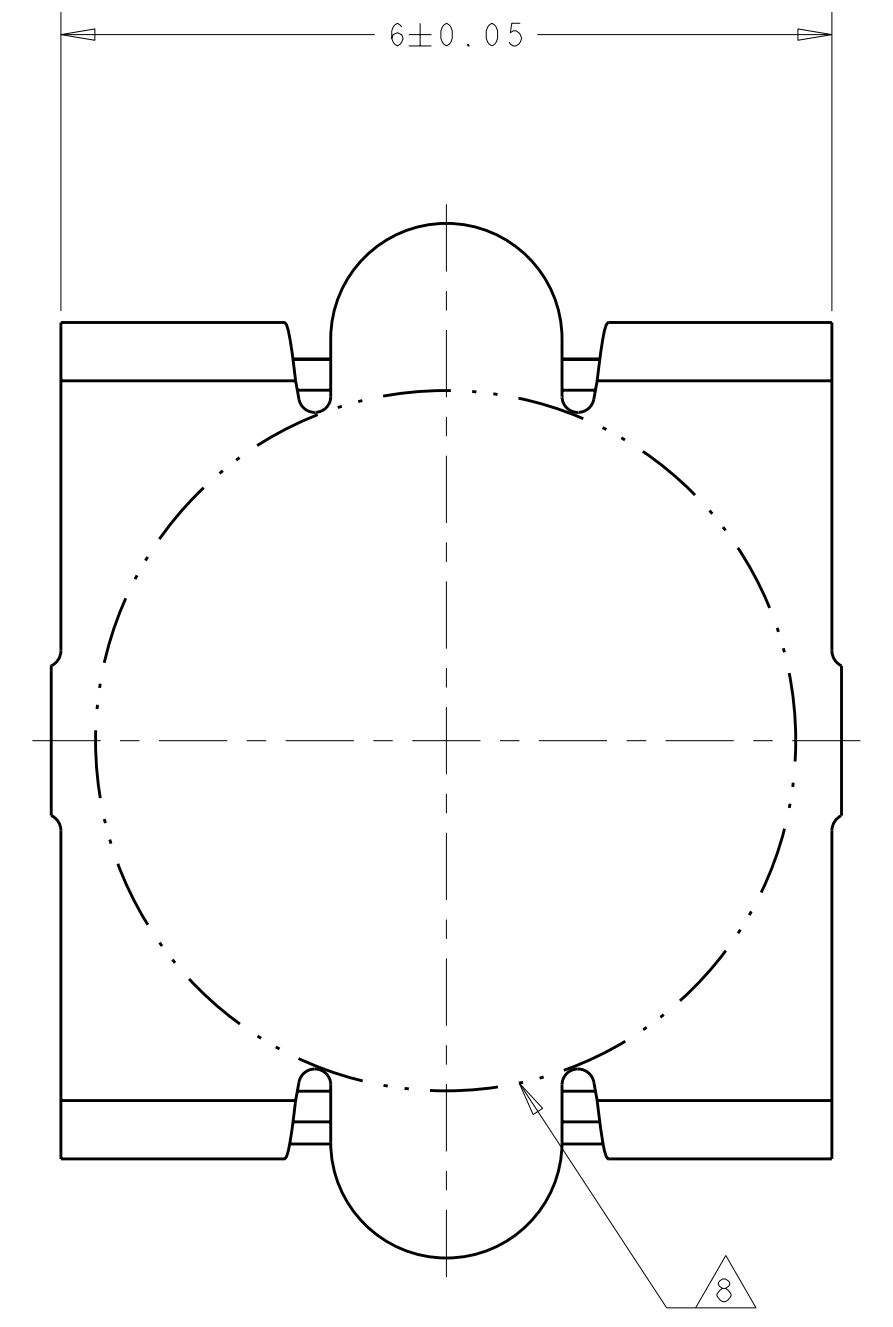
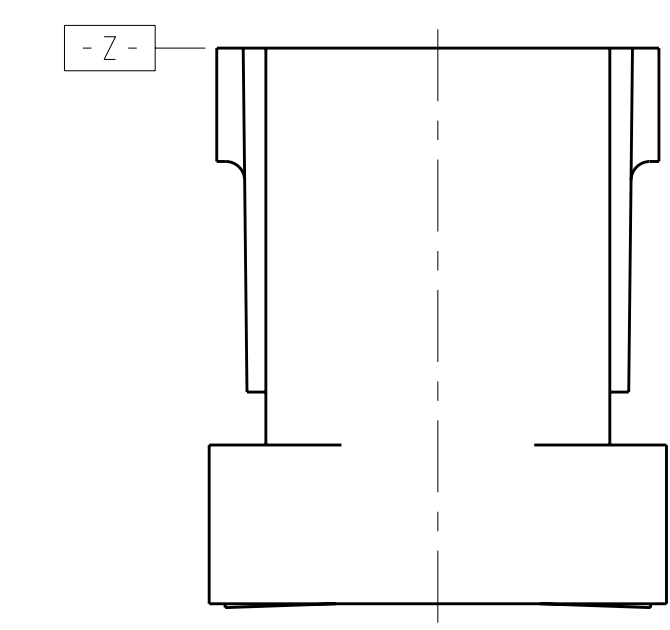
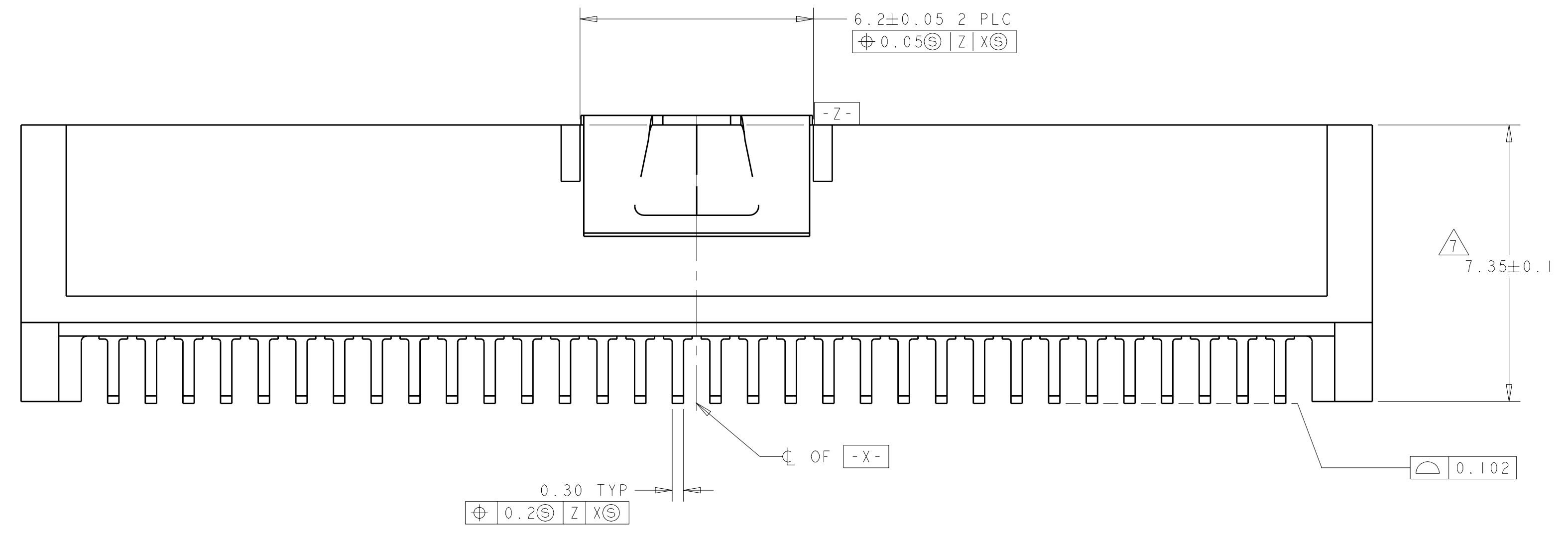

VACUUM COVER

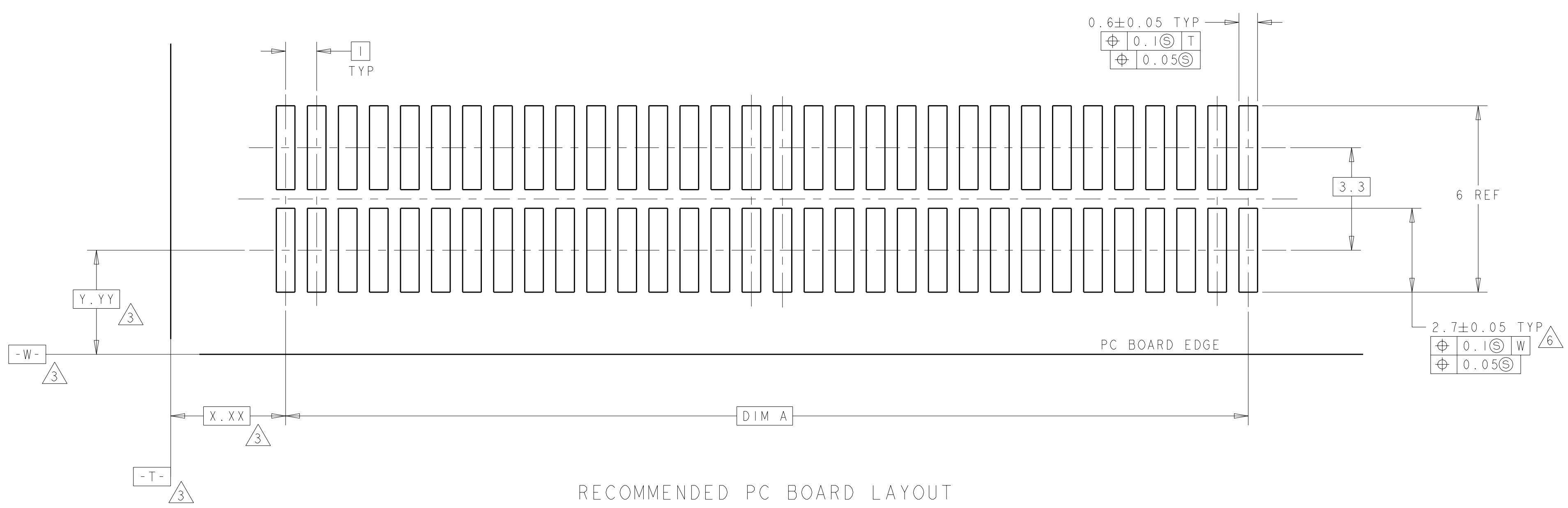

FINISH	DIM C	DIM B	DIM A	MATING CONNECTOR	STACK HGTS	POS	PART NO
9	45.9	44.58	41	5120531-2	14	84	1-5120533-2
9	45.9	44.58	41	5120529-2	11	84	1-5120533-2
9	45.9	44.58	41	5120528-2	9	84	1-5120533-2
9	35.9	34.58	31	5120531-1	14	64	1-5120533-1
9	35.9	34.58	31	5120529-1	11	64	1-5120533-1
9	35.9	34.58	31	5120528-1	9	64	1-5120533-1
2	45.9	44.58	41	5120531-2	14	84	5120533-2
2	45.9	44.58	41	5120529-2	11	84	5120533-2
2	45.9	44.58	41	5120528-2	9	84	5120533-2
2	35.9	34.58	31	5120531-1	14	64	5120533-1
2	35.9	34.58	31	5120529-1	11	64	5120533-1
2	35.9	34.58	31	5120528-1	9	64	5120533-1

DIMENSIONS: mm TOLERANCES UNLESS OTHERWISE SPECIFIED: 9 PLC ± 5 PLC ±0.03 4 PLC ±0.003 ANGLES ±°30' FINISH SEE TABLE		DWN BY: CABBO CHK: R. WERTZ APP'D: R. WERTZ PRODUCT SPEC: 502-1079 APPLICATION SPEC: 114-25045 WEIGHT: - CUSTOMER DRAWING		30SEP04 30SEP04 30SEP04 NAME: R. WERTZ SIZE: A SCALE: 17:1		Tyco Electronics Harrisburg, PA 17105-3608 PLUG ASSY, W/COVER 1.0mm FH(IEEE) CONNECTOR CAGE CODE: 00779 DRAWING NO: 5120533 SHEET 1 OF 1 REV A	
--	--	---	--	---	--	---	--