

14 CIRCUIT SHOWN FOR ILLUSTRATION ONLY.

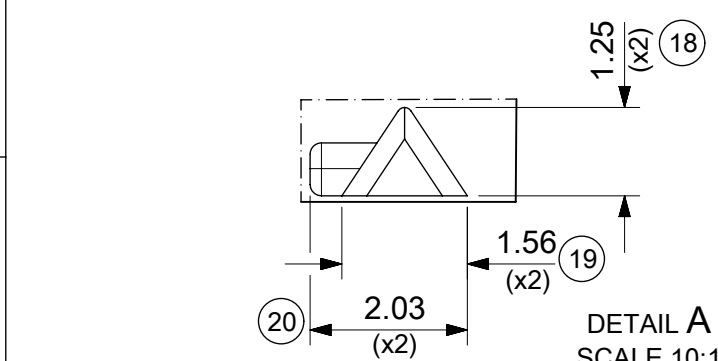
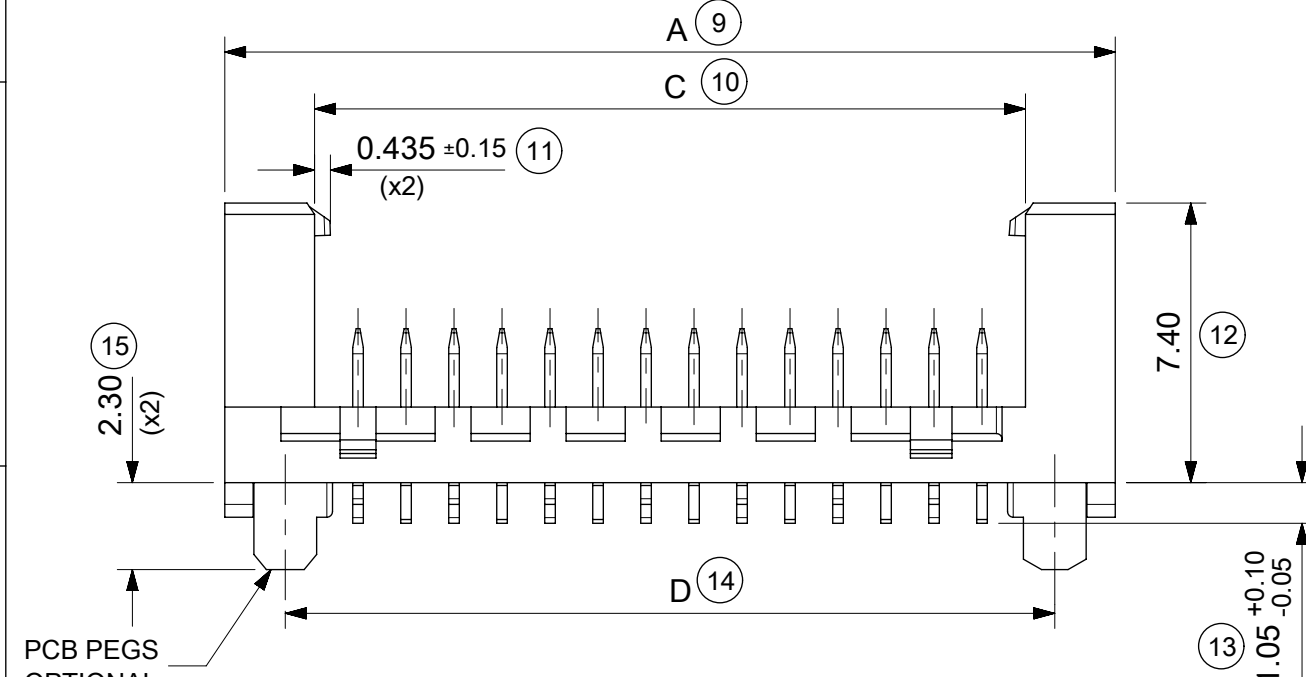

PART NO.	NUMBER OF CKTS	DIMN. A	DIMN. B	DIMN. C	DIMN. D
90816-**04	04	10.86	3.81	6.11	7.66
90816-**06	06	13.40	6.35	8.65	10.20
90816-**08	08	15.94	8.89	11.19	12.74
90816-**10	10	18.48	11.43	13.73	15.28
90816-**12	12	21.02	13.97	16.27	17.82
90816-**14	14	23.56	16.51	18.81	20.36
90816-**16	16	26.10	19.05	21.35	22.90
90816-**18	18	28.64	21.59	23.89	25.44
90816-**20	20	31.18	24.13	26.43	27.98
90816-**22	22	33.72	26.67	28.97	30.52
90816-**24	24	36.26	29.21	31.51	33.06
90816-**26	26	38.80	31.75	34.05	35.60

SEE NOTE-7

NOTES:

- MATERIAL
HOUSING: PPA, GLASS-FILLED, COLOUR: BLACK, UL 94-HB.
TERMINAL: BRASS
 - FINISHES: TERMINAL
Gold : UNDERPLATED 1.27µm MIN NICKEL
3-5µm TIN SELECTIVE
0.76µm MIN. SELECTIVE GOLD
TIN: 3 MICROMETRE MINIMUM OVER NICKEL UNDERPLATE.
 - PRODUCT SPECIFICATION: PS-99020-0011
 - PACKAGING SPECIFICATION: FOR TAPE AND REEL SEE: PK-90816-006
FOR TUBE SEE: PK-90816-007
 - MATES WITH MOLEX 90327 PART SERIES.
 - ALL SMT TAILS TO LIE WITHIN A COPLANARITY BAND OF 0 - 0.10 MICROMETRE REF. FROM EACH OTHER.
 - 4 CIRCUIT PART NOT AVAILABLE IN TAPE AND REEL.
- LAST INSPECTION NUMBER USED: 20

90816 - ** **

CIRCUIT SIZE.

	PCB PEGS	TUBE PACKED	TAPE & REEL PACKED
0	YES	YES	NO
2	YES	NO	YES
3	NO	YES	NO
5	NO	NO	YES

0 = TIN VERSION
3 = 0.76µm GOLD PLATING

FUNCTIONAL SYMBOLS		THIS DRAWING CONTAINS INFORMATION THAT IS PROPRIETARY TO MOLEX ELECTRONIC TECHNOLOGIES, LLC AND SHOULD NOT BE USED WITHOUT WRITTEN PERMISSION		CURRENT REV DESC: CAD MIGRATION		molex	
FA = 0	mm	SCALE	5:1	GENERAL TOLERANCES (UNLESS SPECIFIED)			
FE = 0	ANGULAR TOL ± 2.0°		EC NO: 738955		PICOFLEX SMT LATCHED HEADER		
FD = 0	4 PLACES ±		DRWN: GOWTHP		PRODUCT CUSTOMER DRAWING		
DIVISIONAL SYMBOLS		3 PLACES ±		2023/02/02		DOCUMENT NUMBER	
		2 PLACES ± 0.25		2023/02/16		SD-90816-001	
		1 PLACE ± 0.35		2023/02/20		PSD 001 G1	
		0 PLACES ±		INITIAL REVISION:		DOC TYPE DOC PART REVISION	
		DRAFT WHERE APPLICABLE MUST REMAIN WITHIN DIMENSIONS		DRWN: DBYRNES		2008/08/16	
		THIRD ANGLE PROJECTION		APPR: EFOLAN		2010/11/04	
		DRAWING		SERIES		MATERIAL NUMBER	
		A3		90816		SEE CHART	
		CUSTOMER		GENERAL MARKET		SHEET NUMBER	
		1 OF 2					



RESTRICTED AREA
NO PCB COMPONENTS
ALLOWED

CKT 2.

CKT 1.

RECOMMENDED PCB THICKNESS 1.60±0.14

PCB LAYOUT FOR CLEARANCE FIT WITH PCB PEGS

HEADER VERSIONS 90816-*0**/*2**

VIEWED FROM COMPONENT SIDE

6CKT PART SHOWN FOR REFERENCE



RESTRICTED AREA
NO PCB COMPONENTS
ALLOWED

CKT 2.

CKT 1.

PCB LAYOUT WITHOUT PCB PEGS

HEADER VERSIONS 90816-*3**/*5**

VIEWED FROM COMPONENT SIDE

6CKT PART SHOWN FOR REFERENCE

90816-**26	26	38.80	31.75	35.60
90816-**24	24	36.26	29.21	33.06
90816-**22	22	33.72	26.67	30.52
90816-**20	20	31.18	24.13	27.98
90816-**18	18	28.64	21.59	25.44
90816-**16	16	26.10	19.05	22.90
90816-**14	14	23.56	16.51	20.36
90816-**12	12	21.02	13.97	17.82
90816-**10	10	18.48	11.43	15.28
90816-**08	8	15.94	8.89	12.74
90816-**06	6	13.40	6.35	10.20
90816-**04	4	10.86	3.81	7.66
PART NO.	NUMBER OF CKTS	DIM. E	DIM. F	DIM. G

DOCUMENT STATUS P1 RELEASE DATE 2023/02/20 05:04:35

FUNCTIONAL SYMBOLS	THIS DRAWING CONTAINS INFORMATION THAT IS PROPRIETARY TO MOLEX ELECTRONIC TECHNOLOGIES, LLC AND SHOULD NOT BE USED WITHOUT WRITTEN PERMISSION	CURRENT REV DESC: CAD MIGRATION				
	DIMENSION UNITS: mm SCALE: 5:1 GENERAL TOLERANCES (UNLESS SPECIFIED): ANGULAR TOL ± 2.0° 4 PLACES ± 3 PLACES ± 2 PLACES ± 0.25 1 PLACE ± 0.35 0 PLACES ±	EC NO: 738955 DRWN: GOWTHP CHK'D: GOWTHP APPR: ISHWARG INITIAL REVISION: DRWN: DBYRNES APPR: EFOLAN				
DIVISIONAL SYMBOLS	DRAFT WHERE APPLICABLE MUST REMAIN WITHIN DIMENSIONS THIRD ANGLE PROJECTION 		DRAWING: A3-SIZE SERIES: 90816	MATERIAL NUMBER: SEE SHEET 1 CUSTOMER: GENERAL MARKET	DOCUMENT NUMBER: SD-90816-001 DOC TYPE: PSD DOC PART: 001 REVISION: G1	SHEET NUMBER: 2 OF 2