

SPECIFICATION CONTROL DRAWING

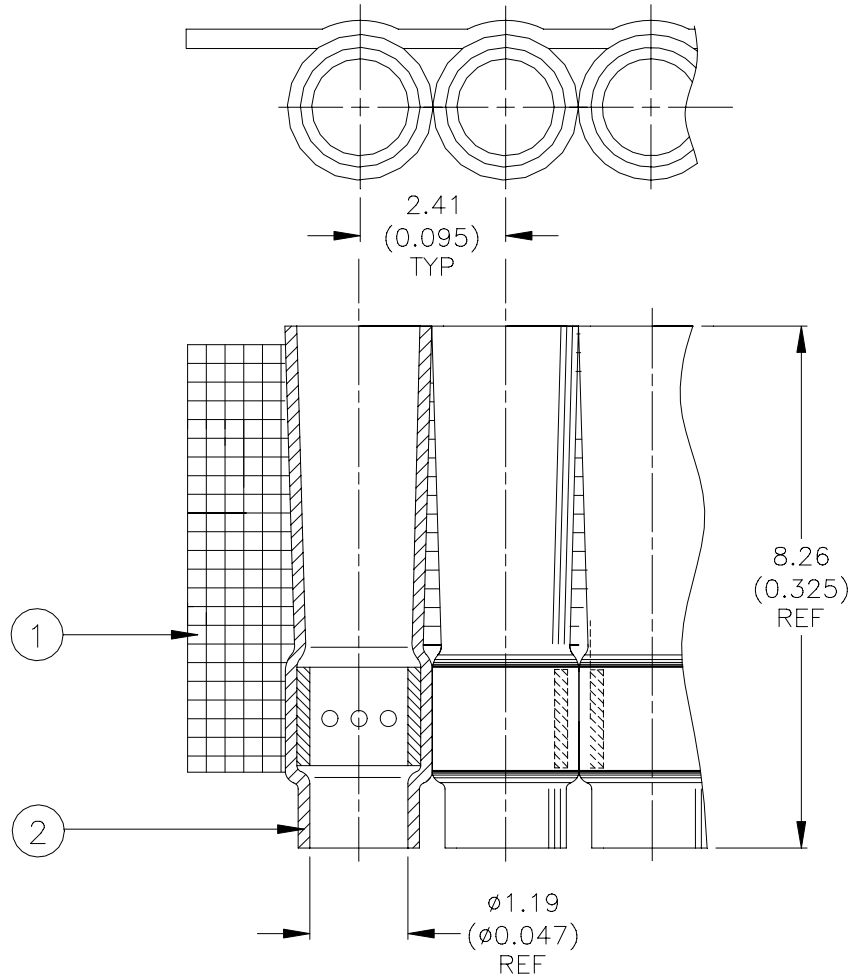

MATERIALS

1. SOLDERSLLEEVE: D-136-07, Quantity Per Assembly: 1000
2. CARRIER STRIP: Adhesive Coated High Temperature Tape

APPLICATION

1. This assembly is for used on Continental MM22 or Winchester SRE connectors.
2. Sleeves are to be installed using Raychem-approved convection or infrared heating tools.
3. The carrier strip is to be removed before heating.

 307 Constitution Drive Menlo Park, CA 94025, USA		Wire and Harnessing Products		TITLE : SOLDERPAK ASSEMBLY, Continental MM22 and Winchester SRE Connectors; 22/26 AWG High Temperature Wire									
UNLESS OTHERWISE SPECIFIED DIMENSIONS ARE IN MILLIMETERS. INCHES DIMENSIONS ARE BETWEEN BRACKETS.				DOCUMENT NO.: D-701-00									
TOLERANCES: 0.00 N/A 0.0 N/A 0 N/A		ANGLES: N/A ROUGHNESS IN MICRON		Raychem reserves the right to amend this drawing at any time. Users should evaluate the suitability of the product for their application.		DCR NUMBER: D010046		REPLACES: N/A					
DRAWN BY: M. FORONDA		DATE: 26-Jan.-01		PROD. REV. D		DOC ISSUE: 1		SCALE: None		SIZE: A		SHEET: 1 of 1	

If this document is printed it becomes uncontrolled. Check for the latest revision.