

# **AT91SAM7A2-EK Evaluation Board**

.....

## **User Guide**







## Table of Contents

---

### Section 1

Overview .....	1-1
1.1 Scope .....	1-1
1.2 Deliverables .....	1-1
1.3 AT91SAM7A2 Evaluation Board .....	1-1

---

### Section 2

Setting Up the AT91SAM7A2-EK Evaluation Board .....	2-1
2.1 Requirements .....	2-1
2.2 Electrostatic Warning .....	2-1
2.3 Layout .....	2-1
2.4 Voltage .....	2-2
2.5 Powering Up the Board .....	2-2
2.6 Measuring Current Consumption on the AT91SAM7A2 .....	2-2
2.7 AT91SAM7A2-EK Block Diagram .....	2-3

---

### Section 3

Board Description .....	3-1
3.1 AT91SAM7A2-EK Top Level .....	3-1
3.2 AT91SAM7A2 Processor .....	3-1
3.3 Power Supply Block .....	3-1
3.4 Application Interface .....	3-2
3.5 Serial Communication Ports .....	3-2
3.6 CAN Bus .....	3-2
3.7 LIN Buses and RS-232 Lines .....	3-3
3.8 Crystal Oscillators and Clock Distribution .....	3-5
3.9 Memory Organization .....	3-5
3.10 I/O Expansion .....	3-5
3.11 External Bus Interface .....	3-5
3.12 ICE Interface .....	3-6

---

### Section 4

Schematics .....	4-1
4.1 Schematics .....	4-1





# Section 1

---

## Overview

- 
- 1.1 Scope** The AT91SAM7A2-EK Evaluation Board enables real-time code development and evaluation. It supports the AT91SAM7A2 microcontroller.
- 
- 1.2 Deliverables** The evaluation board is supplied with:
- an AT91SAM7A2-EK evaluation board featuring an AT91SAM7A2 with an LCD connected
  - a bare power lead, a fuse, 2 jumpers
  - a 25-pin parallel cable
  - the AT91 CD-ROM including:
    - Summary and full datasheets, datasheets with electrical and mechanical characteristics
    - Application notes and Getting Started documents for all development boards and AT91 microcontrollers
    - An AT91 Software package with C and assembly listings is also provided. This allows the user to begin evaluating the AT91 ARM<sup>®</sup> Thumb<sup>®</sup> 32-bit microcontroller quickly.
- 
- 1.3 AT91SAM7A2 Evaluation Board** The board consists of:
- The Atmel AT91SAM7A2 ARM-based microcontroller
  - Memories
    - 512 Kbyte 16-bit SRAM
    - 2 Mbyte 16-bit Flash
  - Footprint for an 8 Kbyte SPI EEPROM
  - Serial Communication Lines
    - 4 CAN ports (3 wired on SubD9 connector and 1 wired on a 10-pin connector)
    - 2 LIN ports
    - 1 RS232 interface

- Main machine interfaces
  - 1 LCD (2 lines x 16 characters)
  - 1 reset push button
  - 1 piezoelectric buzzer
  - 3 LEDs connected to the PIO/Timer module
  - 3 programmable push buttons
- ICE interface
  - A standard 20-pin ICE interface connector
  - An embedded ICE interface linked to SubD25 connector
- Power supply features
  - DC power line filtering
  - Diode bridge
  - Adjustable voltage regulators
- Clocks
  - 6 MHz and 32.768 KHz crystals
- Expansion connectors
  - Most chip I/Os accessible via a 100-pin connector
  - EBI expansion connector allowing plug-in of memory board or Ethernet board



## Section 2

# Setting Up the AT91SAM7A2-EK Evaluation Board

- 2.1 Requirements** In order to set up the AT91SAM7A2-EK Evaluation Board, the following elements are required:
- the AT91SAM7A2-EK Evaluation Board itself
  - a DC power supply capable of supplying 7V to 12V @ 400 mA (not supplied)

- 2.2 Electrostatic Warning** The AT91SAM7A2-EK Evaluation Board is shipped in protective anti-static packaging. The board must not be subjected to high electrostatic potentials. A grounding strap or similar protective device should be worn when handling the board. Avoid touching the component pins or any other metallic element.

- 2.3 Layout** *Figure 2-1. Top Level Layout*

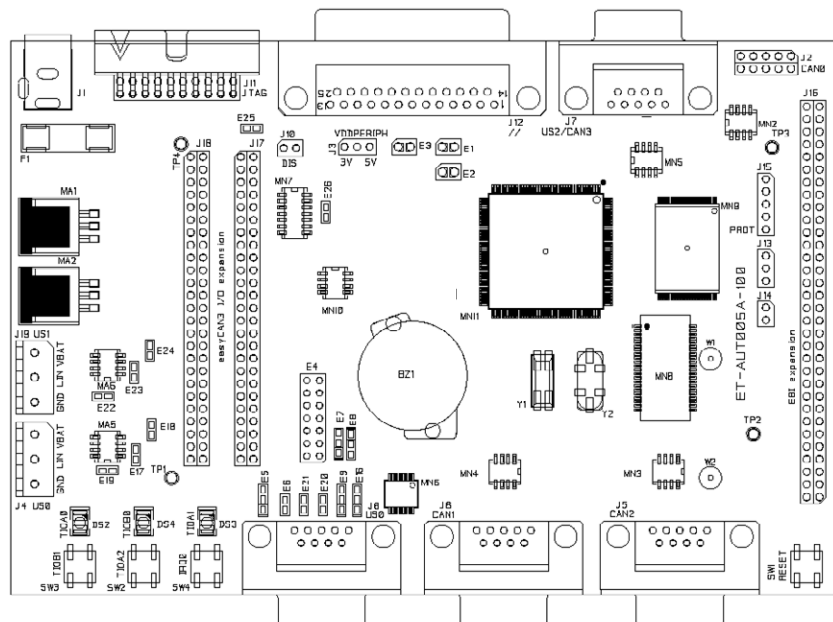

## 2.4 Voltage

DC power is supplied to the board via the 2.1 mm connector (J1) shown in Figure 2-2. The polarity of the power supply is not critical. The minimum voltage required is 7V. The supply must be isolated from ground. The 0 volts of the on-board regulated supplies can be connected to ground via any one of the 4 test points, TP1 to TP4.

**Figure 2-2.** 2.1mm Connector

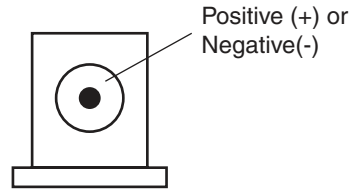

The board has a voltage regulator providing +3.3V and another providing +5V. These regulators allow the input voltage to be from 7V to 12V.

## 2.5 Powering Up the Board

**Figure 2-3.** Powering Up the Board

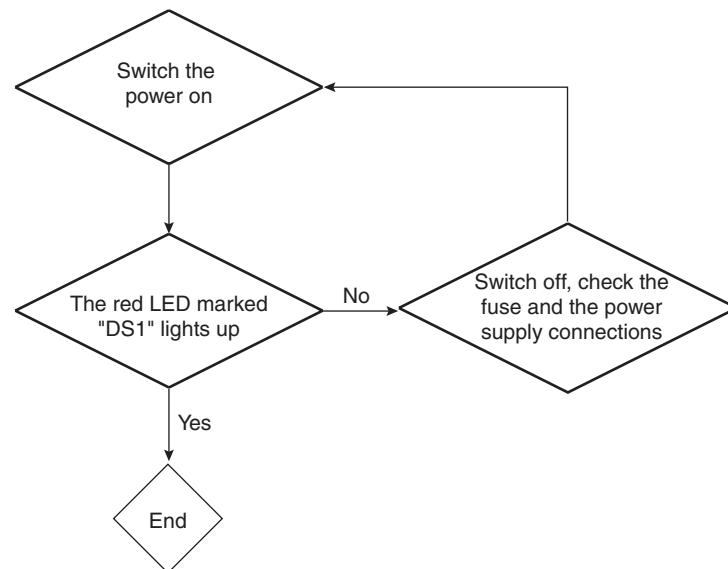

## 2.6 Measuring Current Consumption on the AT91SAM7A2

The board is designed to generate the entire power supply of the AT91SAM7A2 device. The PCB power tracks to the ARM7 core, the I/O and the analog cells are independent. This feature enables measurement of the current consumption of the different major parts of the AT91SAM7A2 device.

**Table 2-1.** Current Consumption Measurement Procedure

Block to Measure	Strap to Unsolder	Action
Core	E1	Connect an ammeter in place of the strap
Analog Cells	E2	
I/O Cells	E3	



## 2.7 AT91SAM7A2-EK Block Diagram

Figure 2-4. AT91SAM7A2-EK Evaluation Board Block Diagram

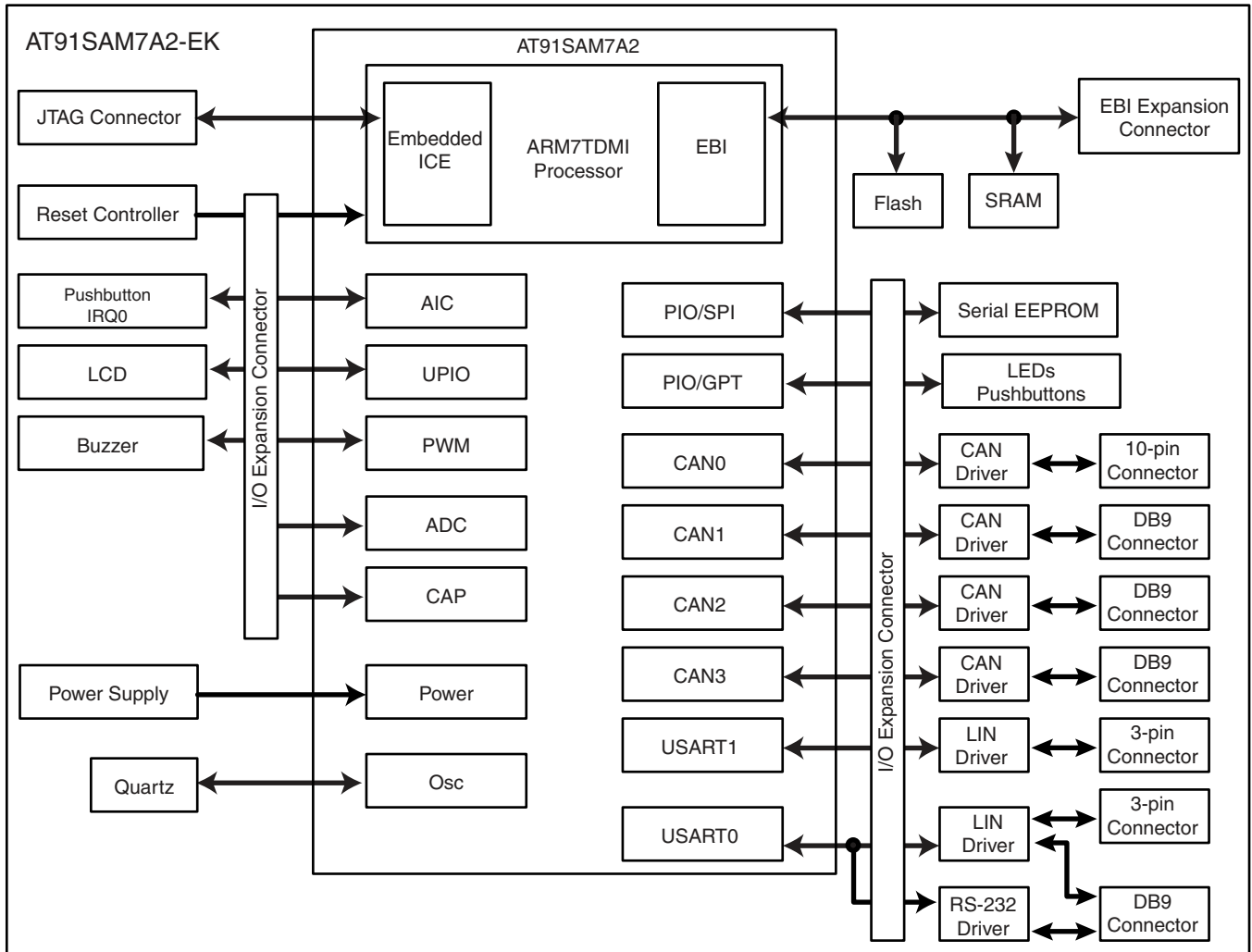





## Section 3

# Board Description

- 
- 3.1 AT91SAM7A2-EK Top Level** The AT91SAM7A2-EK evaluation board consists of 10 main blocks. Each block is described in the sections that follow.
- The block diagram is shown in Figure 2-4.
- 
- 3.2 AT91SAM7A2 Processor** The processor is based on an ARM7TDMI<sup>®</sup> 32-bit core and provides
- Standard modules (e.g., timers and USART)
  - Specific modules (e.g., CAN2.0A, CAN2.0B)
- The footprint is for a 176-pin TQFP package.
- The jumpers E1, E2 and E3 can be removed to allow measurement of the current required by the microcontroller.
- 
- 3.3 Power Supply Block** The voltage regulator provides 3.3V, 5V and analog 3.3V to the board and lights the red LED when operating.
- Power can be applied via the 2.1 mm connector to the regulator in either polarity because of the diode rectifying circuit.
- The regulators can tolerate supply transients up to 30V although they shut down without damage if they overheat.
- The I/O power is configurable. Jumper J3 allows the selection of either 3.3V or 5V. The board also provides jumpers that measure the power of the microcontroller.
- By unsoldering straps, an ammeter can be connected. Strap E1 is used to measure core consumption. Strap E3 is used to measure I/O cell consumption; the analog cell consumption is measured by jumper E2.

### 3.4 Application Interface

The board provides the following application interfaces:

**Table 3-1.** Board Application Interfaces

Part	Description
Reset push button	Detects and then resets the board when the 3.3V supply voltage drops below 2.7V. Allows manual reset of both board and microcontroller.
Red LED DS2	Connected to timer (or I/O) pin TIOA0 (GPT module)
Orange LED DS3	Connected to timer (or I/O) pin TIOA1 (GPT module)
Green LED DS4	Connected to timer (or I/O) pin TIOB0 (GPT module)
SW2 push button SW3 push button	Connected to input pins TIOA2 and TIOB1 (or I/O) of the timer (GPT module)
SW4 push button	Connected to GIC (Generic Interrupt Controller) module IRQ0 input. Allows the user to generate interrupts manually.
Buzzer	Connected to the PWM0 output. It demonstrates the PWM (Pulse Width Modulation) features. It is possible to enable/disable the buzzer by opening/closing jumper J10. The PWM0 output signal can be a 3V3 or 5V (jumper J3). The voltage influences the volume of the sound.
LCD connected to PIO	Displays 2 lines of 16 characters each. The LCD is driven by the PIO which can be powered by 3V3 or 5V. The LCD tolerates these two voltages. Users can display messages on the LCD. The contrast voltage is provided by the PWM1 and can be measured by ADC0 channel 0.

### 3.5 Serial Communication Ports

The AT91SAM7A2-EK can control:

- Four CAN buses
- Two LIN buses
- One RS-232 line

### 3.6 CAN Bus

The CAN0 module is connected to a 5 x 2 connector (J2) on a 0.1" (2.54 mm) pitch via the CAN driver MN2.

The CAN1 and CAN2 modules are connected to two female SubD9 connectors (J5 and J6) via the CAN drivers MN3 and MN4. CAN3 is connected to one male SubD9 connector (J7) via the CAN driver MN5. The pinout is described in Table 3-2.

**Figure 3-1.** Female DB9 Connector

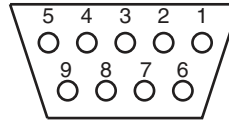

**Table 3-2.** Pinout

SubD9 Pin	Function
4	CAN-L
3	GND
8	CAN-H
others	Not connected

The CAN3 module is connected to a male subD9 connector (J7) via the CAN driver MN5. The pinout is described in Table 3-3.

**Table 3-3.** Pinout

SubD9 Pin	Function
2	CAN-L
3	GND
7	CAN-H
others	Not connected

The CAN bus resistive load is 60 Ohm. It is made up of two 120 Ohm resistors in parallel. The recommended CAN bus load is 60 Ohm. Depending on the external input bus resistor, users can disconnect resistors to achieve the correct bus load.

### 3.7 LIN Buses and RS-232 Lines

Via USART modules, the AT91SAM7A2-EK board provides the following:

- Two LIN buses
- One RS-232 line

**Table 3-4.** Communication Peripherals

Peripheral	Connector	Driver
USART0	J8 (male DB9) or J4 (3 points)	RS-232 driver (MN6) LIN driver (MA5)
USART1	J19 (3 points)	LIN driver (MA6)
CAN0	J2 (5 x 2 connector on a 0.1" (2.54 mm) pitch)	CAN driver (MN2)
CAN1	J6 (female DB9)	CAN driver (MN4)
CAN2	J5 (female DB9)	CAN driver (MN3)
CAN3	J7 (male DB9)	CAN driver (MN5)

**Table 3-5.** Serial Interface

Peripheral	Use	Connector	Closed Straps	Open Straps	
USART0	in RS-232	DB9		E5: 1 - 2	
			E5: 2 - 3	E9: 2 - 3	
			E6	E16: 2 - 3	
			E9: 1 - 2	E20	
			E16: 1 - 2	E21	
	as LIN <sup>(1)</sup> (Local Interconnect Network)	DB9	E5: 1 - 2	E5: 2 - 3	
			E9: 2 - 3	E6	
			E16: 2 - 3	E9: 1 - 2	
			E18	E16: 1 - 2	
			E20	E17	
			E21	E19	
			3 points		E9: 1 - 2
				E18	E16: 1 - 2
				E9: 2 - 3	E17
E16: 2 - 3	E19				
USART1	as LIN <sup>(2)</sup>	3 points		E20	
			E24	E21	
USART1	as LIN <sup>(2)</sup>	3 points	E24	E22, E23	

- Notes: 1. For the master LIN node, users should solder a 1K resistor on R26 footprint and a diode on CR5 footprint.  
 2. For the master LIN node, users should solder a 1K resistor on R27 footprint and a diode on CR6 footprint.

The pinout for the DB9 connector J6 is described in Table 3-6.

**Table 3-6.** DB Pinout

DB Pin	Function
3	Ground
8	LIN
9	Battery (8V - 18V)
Others	Not connected

**Figure 3-2.** Male DB9 Connector

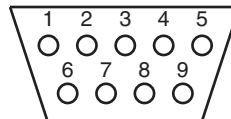

---

**3.8 Crystal Oscillators and Clock Distribution** The system clock is derived from a 6 MHz crystal oscillator mounted on board. The on-chip PLL-based frequency multiplier results in a master clock at 30 MHz. A 32 kHz crystal oscillator is used for the low-power mode and the Watchtimer module.

---

**3.9 Memory Organization** The Flash memory is an AT49BV1614A (1Mx16-bit). Write-protection for half of the on-board Flash memory is provided. Output 4 of Jumper J15 drives the address pin 20 of the Flash.

To access the whole memory, close jumper J15: 3 - 4.

To protect the upper memory and access only the lower memory (from 0x40000000 to 0x40080000: only 1 Mbyte), close jumper J15: 4 - 5.

The mapping defined by the boot software is shown in Table 3-7.

**Table 3-7.** Memory Mapping

Element	Address
Flash	0x40000000
SRAM	0x48000000

---

**3.10 I/O Expansion** Two I/O expansion connectors provide the users with the general-purpose I/O (GPIO) lines, analog lines, VDD and ground. The jumper J10 (DIS) can be used to disconnect application board features, such as the buzzer or RS-232 drivers. The connectors are not fitted at the factory; however, the user can fit any 25 x 2 connector on a 0.1" (2.54 mm) pitch. Figure 4-9 shows the connector pin-out.

---

**3.11 External Bus Interface** Figure 4-7 shows one AT49BV1614A with a 2 Mbyte 16-bit Flash and a 512 Kbyte 16-bit SRAM device.

Figure 4-7 also shows the bus expansion connector that, like the I/O expansion connector, is not fitted at the factory. The user can fit any 32 x 2 connector on a 0.1" (2.54 mm) pitch to gain access to the data, address, chip select, read/write, oscillator output and wait state pins. VDD and ground are available on the connector.

On-board jumpers (J13, J14 and J15) allow the users to connect Chip Selects either to on-board memories or to the expansion connector.

In most case, jumpers should be set up as follows:

- Close J13: 2 - 3. On-board SRAM chip select is driven by NCS1.
- Close J15: 3 - 4. On-board Flash address line 20 is driven. Users can access the whole memory space.

Others are left open.

---

### 3.12 ICE Interface

An ARM®-standard 20-pin box header (J11) is provided to enable connection of an ICE interface to the JTAG inputs on the AT91SAM7A2 device. This allows code to be developed on the board without the use of system resources such as memory and serial ports. A mini JTAG interface is embedded on the board. It is accessed by a parallel port connector (J12). It can be used with GNU Tools, Metaware® and Green Hills®Multi2K.

**Note:** This mini JTAG interface does not work with ARM Developer Suite™.

**Note:** To use a standard external ICE interface in target powered mode, it is necessary to close the strap E25 that enables VCC power supply on the JTAG port.





# Section 4

---

## Schematics

---

### 4.1 Schematics

**Table 4-1.** AT91SAM7A2 Schematics

Figure Reference	Denomination
Figure 4-1	AT91SAM7A2
Figure 4-2	Power
Figure 4-3	Application Interface
Figure 4-4	Serial Com Interface 1/2
Figure 4-5	Serial Com Interface 2/2
Figure 4-6	ICE Interface - Quartz PLL
Figure 4-7	EBI
Figure 4-8	EBI Expansion Connector
Figure 4-9	Expansion Connector

Figure 4-1. AT91SAM7A2

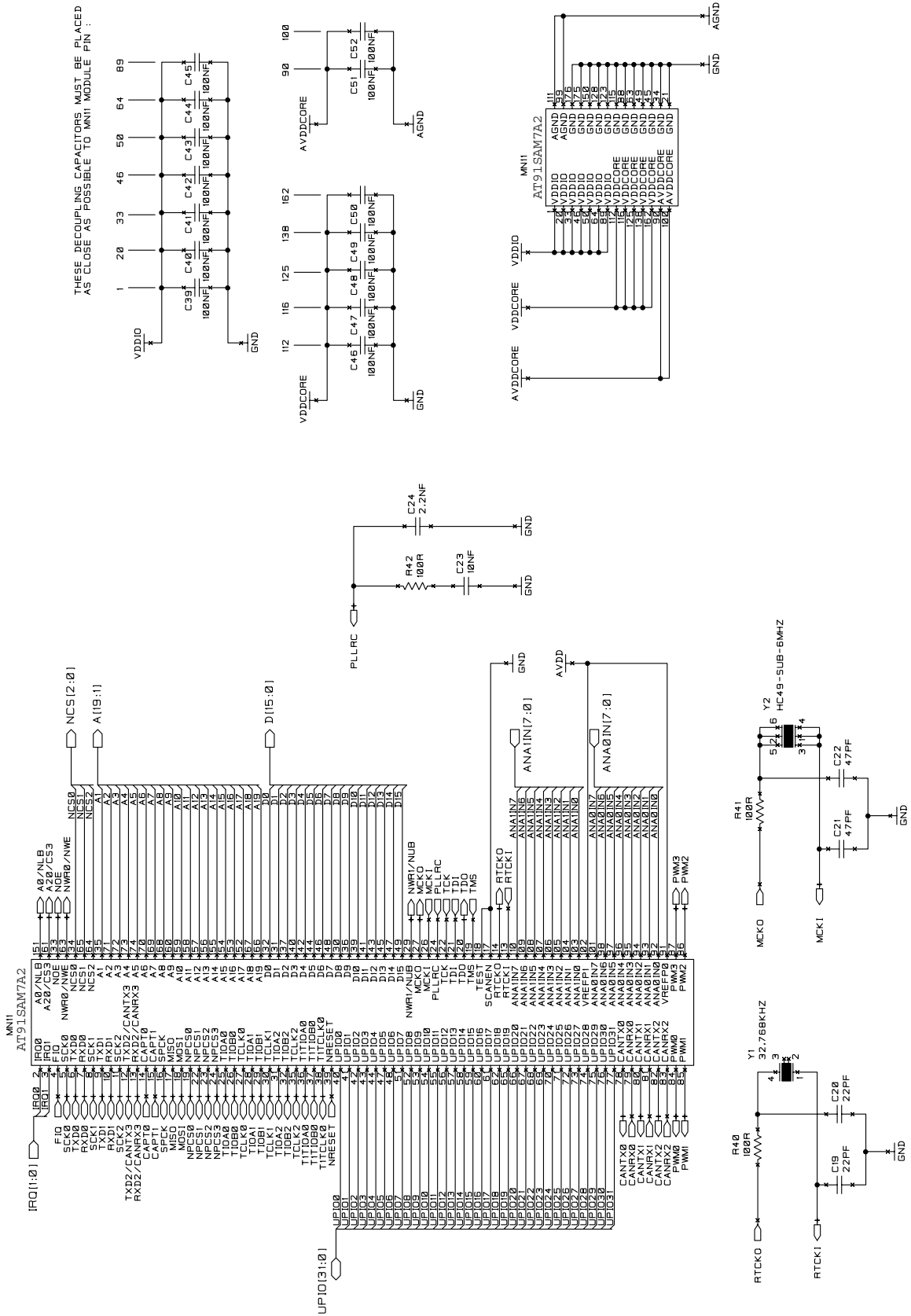

Figure 4-2. Power

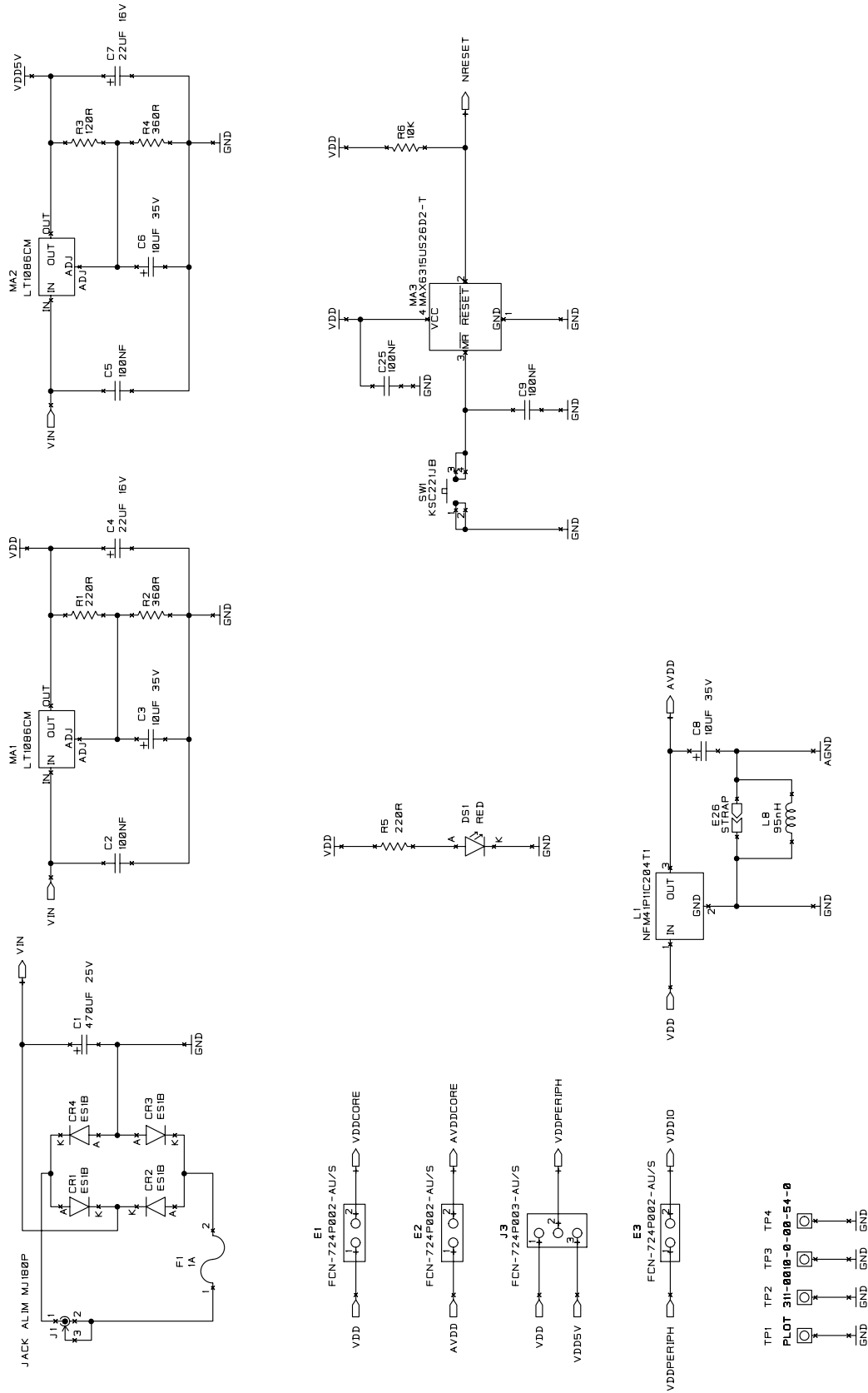

Figure 4-3. Application Interface

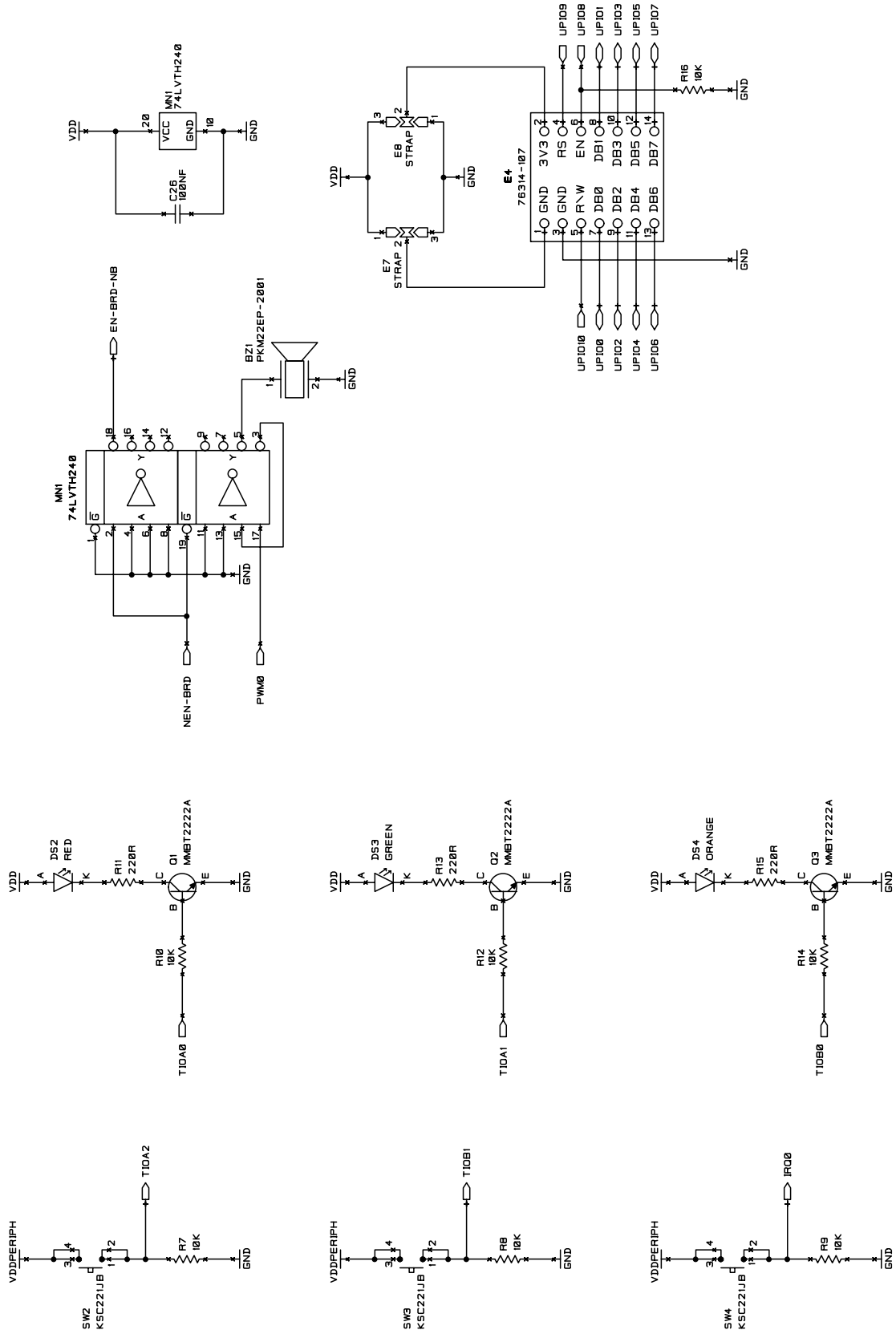

Figure 4-4. Serial Com Interface 1/2

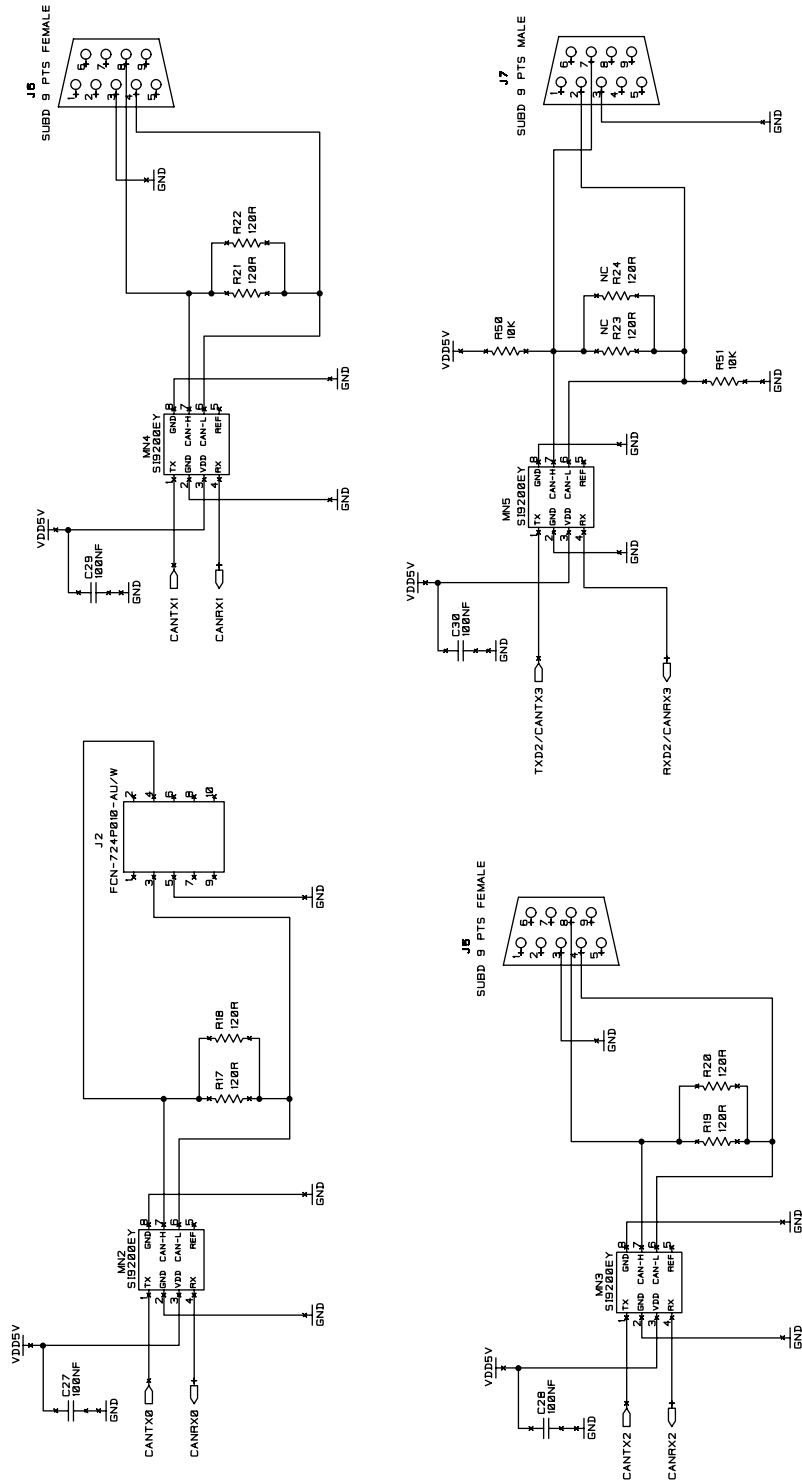



Figure 4-6. ICE Interface - Quartz PLL

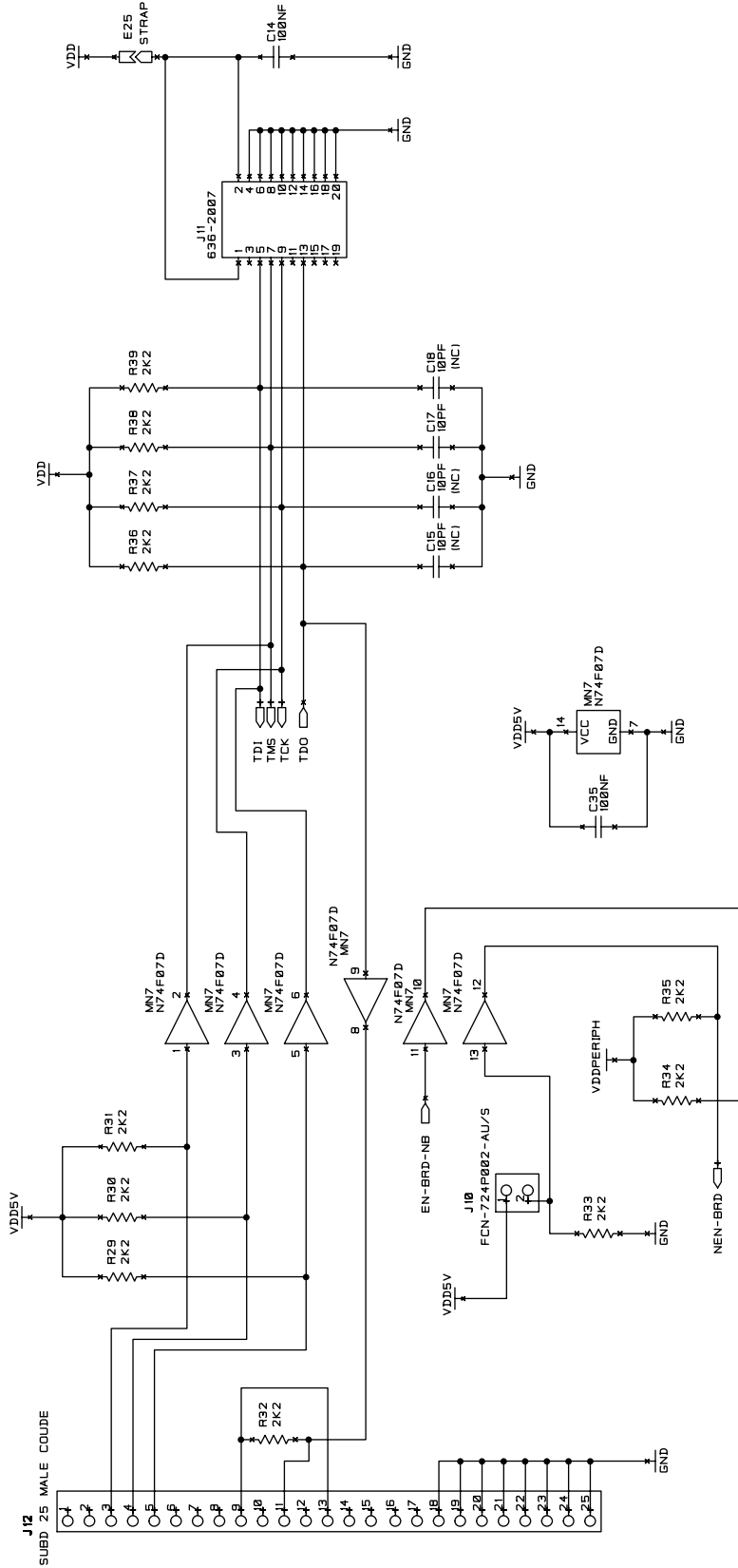
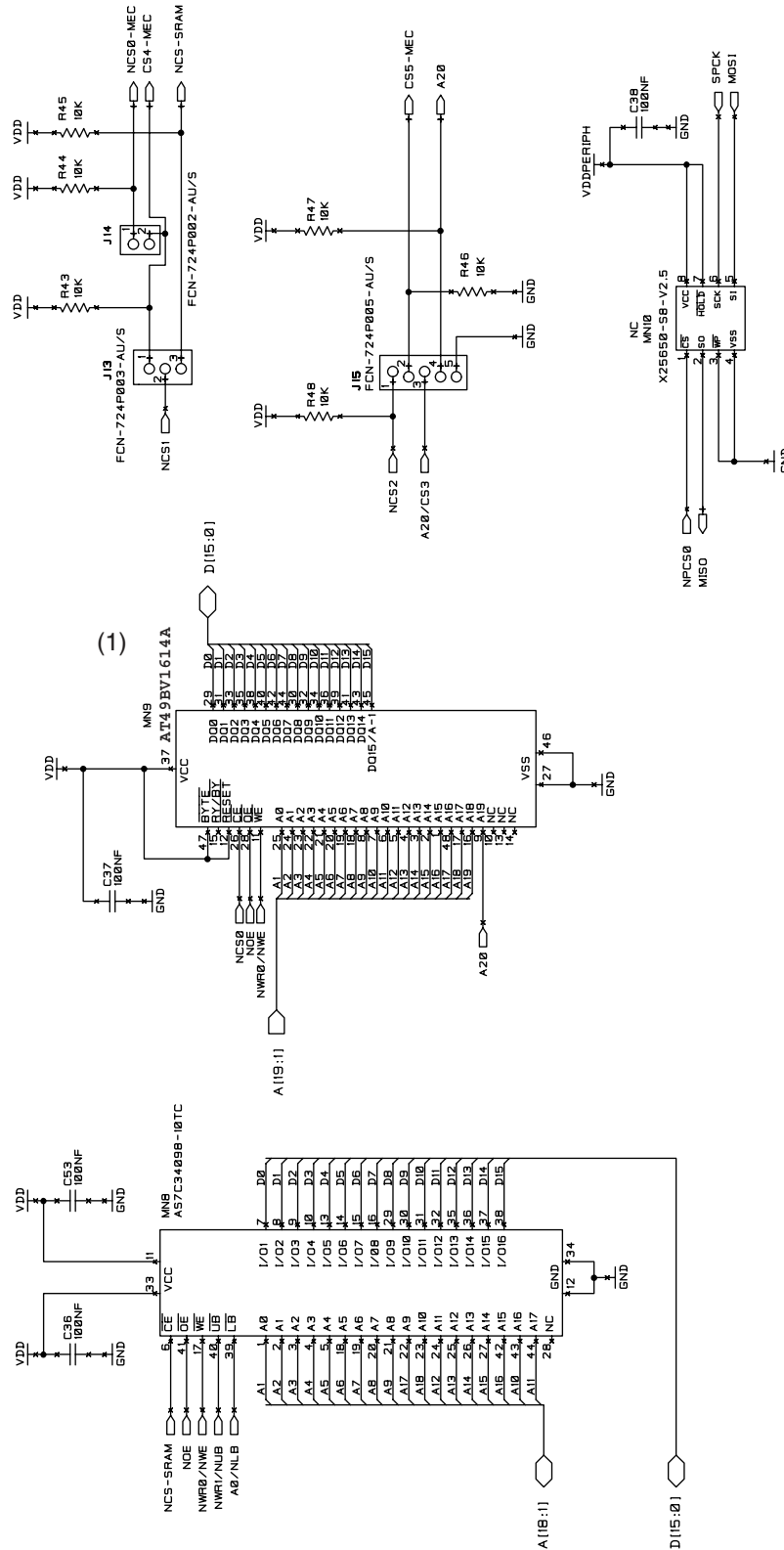

Figure 4-7. Memories



Note: 1. The board may be fitted with an AT49BV162A in place of an AT49BV1614A. In this case the pins; 12, 13, 14 are soldered together in production.



Figure 4-8. EBI Expansion

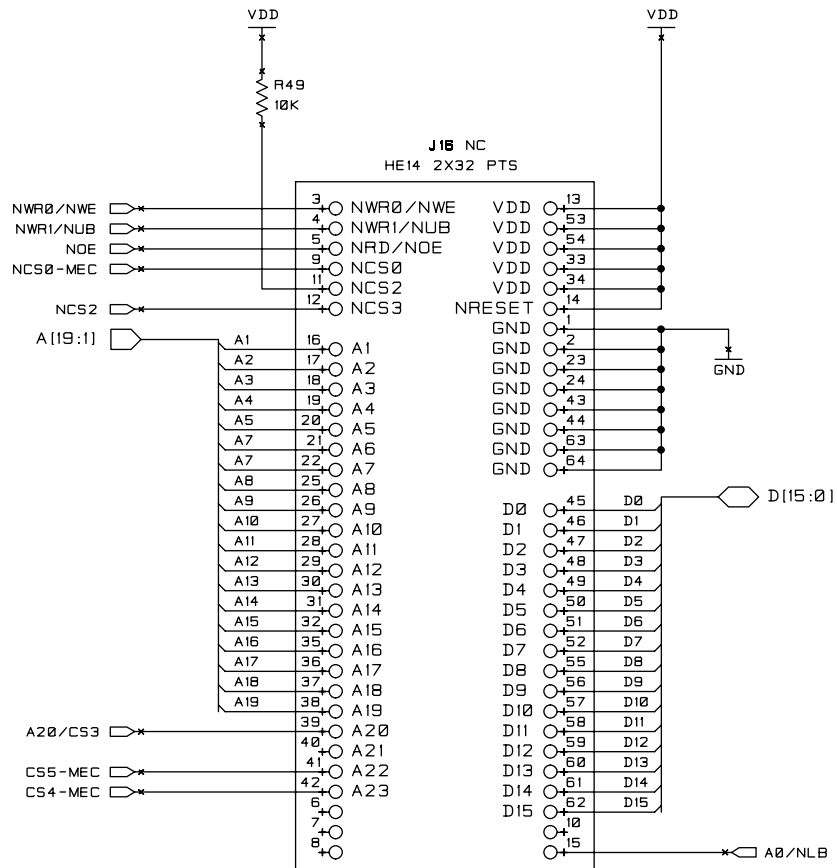
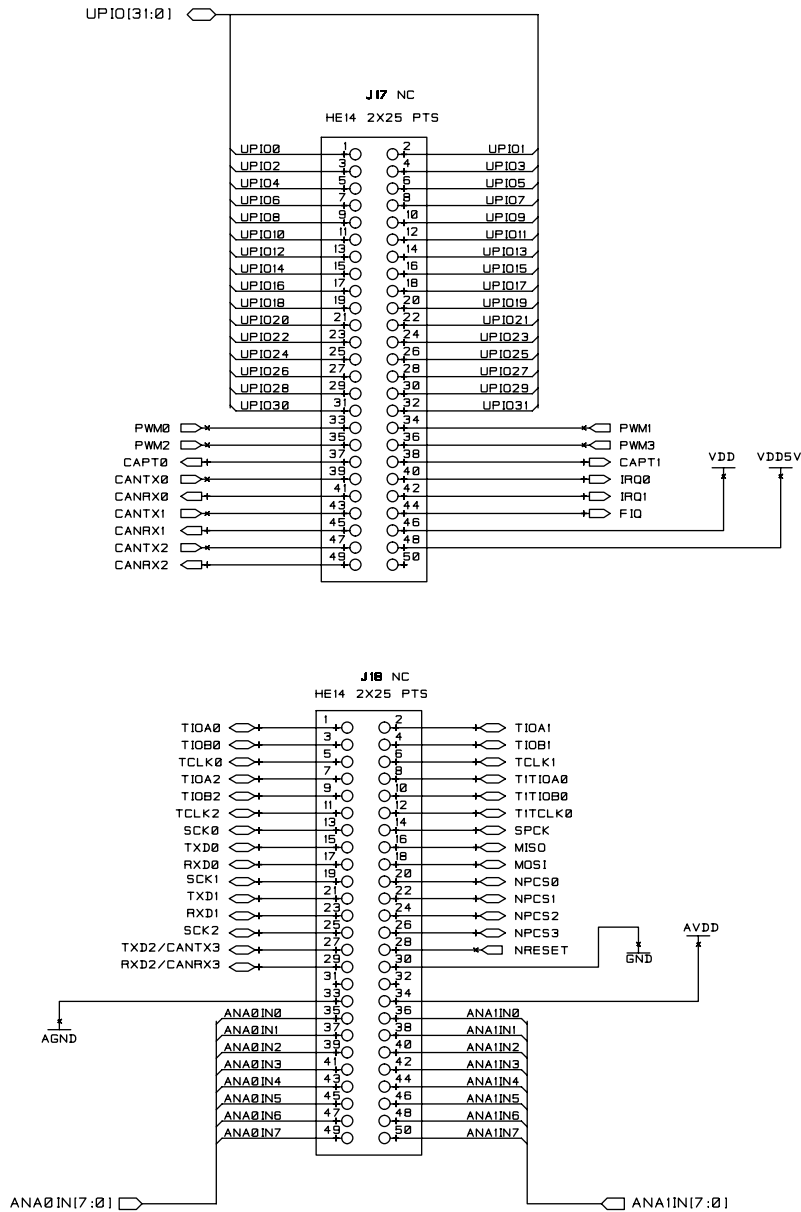

Figure 4-9. Expansion Connector





## Atmel Corporation

2325 Orchard Parkway  
San Jose, CA 95131, USA  
Tel: 1(408) 441-0311  
Fax: 1(408) 487-2600

## Regional Headquarters

### Europe

Atmel Sarl  
Route des Arsenaux 41  
Case Postale 80  
CH-1705 Fribourg  
Switzerland  
Tel: (41) 26-426-5555  
Fax: (41) 26-426-5500

### Asia

Room 1219  
Chinachem Golden Plaza  
77 Mody Road Tsimshatsui  
East Kowloon  
Hong Kong  
Tel: (852) 2721-9778  
Fax: (852) 2722-1369

### Japan

9F, Tonetsu Shinkawa Bldg.  
1-24-8 Shinkawa  
Chuo-ku, Tokyo 104-0033  
Japan  
Tel: (81) 3-3523-3551  
Fax: (81) 3-3523-7581

## Atmel Operations

### Memory

2325 Orchard Parkway  
San Jose, CA 95131, USA  
Tel: 1(408) 441-0311  
Fax: 1(408) 436-4314

### Microcontrollers

2325 Orchard Parkway  
San Jose, CA 95131, USA  
Tel: 1(408) 441-0311  
Fax: 1(408) 436-4314

La Chantrerie  
BP 70602  
44306 Nantes Cedex 3, France  
Tel: (33) 2-40-18-18-18  
Fax: (33) 2-40-18-19-60

### ASIC/ASSP/Smart Cards

Zone Industrielle  
13106 Rousset Cedex, France  
Tel: (33) 4-42-53-60-00  
Fax: (33) 4-42-53-60-01

1150 East Cheyenne Mtn. Blvd.  
Colorado Springs, CO 80906, USA  
Tel: 1(719) 576-3300  
Fax: 1(719) 540-1759

Scottish Enterprise Technology Park  
Maxwell Building  
East Kilbride G75 0QR, Scotland  
Tel: (44) 1355-803-000  
Fax: (44) 1355-242-743

### RF/Automotive

Theresienstrasse 2  
Postfach 3535  
74025 Heilbronn, Germany  
Tel: (49) 71-31-67-0  
Fax: (49) 71-31-67-2340

1150 East Cheyenne Mtn. Blvd.  
Colorado Springs, CO 80906, USA  
Tel: 1(719) 576-3300  
Fax: 1(719) 540-1759

### Biometrics/Imaging/Hi-Rel MPU/ High Speed Converters/RF Datacom

Avenue de Rochepleine  
BP 123  
38521 Saint-Egreve Cedex, France  
Tel: (33) 4-76-58-30-00  
Fax: (33) 4-76-58-34-80

---

## Literature Requests

[www.atmel.com/literature](http://www.atmel.com/literature)

**Disclaimer:** The information in this document is provided in connection with Atmel products. No license, express or implied, by estoppel or otherwise, to any intellectual property right is granted by this document or in connection with the sale of Atmel products. **EXCEPT AS SET FORTH IN ATMEL'S TERMS AND CONDITIONS OF SALE LOCATED ON ATMEL'S WEB SITE, ATMEL ASSUMES NO LIABILITY WHATSOEVER AND DISCLAIMS ANY EXPRESS, IMPLIED OR STATUTORY WARRANTY RELATING TO ITS PRODUCTS INCLUDING, BUT NOT LIMITED TO, THE IMPLIED WARRANTY OF MERCHANTABILITY, FITNESS FOR A PARTICULAR PURPOSE, OR NON-INFRINGEMENT. IN NO EVENT SHALL ATMEL BE LIABLE FOR ANY DIRECT, INDIRECT, CONSEQUENTIAL, PUNITIVE, SPECIAL OR INCIDENTAL DAMAGES (INCLUDING, WITHOUT LIMITATION, DAMAGES FOR LOSS OF PROFITS, BUSINESS INTERRUPTION, OR LOSS OF INFORMATION) ARISING OUT OF THE USE OR INABILITY TO USE THIS DOCUMENT, EVEN IF ATMEL HAS BEEN ADVISED OF THE POSSIBILITY OF SUCH DAMAGES.** Atmel makes no representations or warranties with respect to the accuracy or completeness of the contents of this document and reserves the right to make changes to specifications and product descriptions at any time without notice. Atmel does not make any commitment to update the information contained herein. Atmel's products are not intended, authorized, or warranted for use as components in applications intended to support or sustain life.



© Atmel Corporation 2005. **All rights reserved.** Atmel®, logo and combinations thereof, Everywhere You Are® and others are registered trademarks, and others are the trademarks of Atmel Corporation or its subsidiaries. ARM®, ARM Powered logo and others are registered trademarks of ARM Limited. Other terms and product names may be the trademarks of others.



Printed on recycled paper.

6115B-ATARM-10-May-05